

Equipment
for engineering
education



Environmental engineering

Sustainable technology for environmental protection



Table of contents

Welcome to GUNT

In this catalogue, we present a comprehensive overview of our innovative demonstration and experimental units.

GUNT units are used for:

- education in technical professions
- training and education of technical personnel in trade and industry
- studies in engineering disciplines

Environmental engineering

	Introduction	004
1	Water	008
2	Air	058
3	Soil	070
4	Waste	092
	Index	110
	Product overview	112

Imprint

© 2026 G.U.N.T. Gerätebau GmbH. Any reuse, storage, duplication and reproduction of content – even in extracts – is prohibited without the written approval of G.U.N.T. Gerätebau GmbH. GUNT is a registered trademark. This means GUNT products are protected, and subject to copyright.

No liability can be accepted for any misprints.
Subject to change without notice.

Image credits: G.U.N.T. Gerätebau GmbH, manufacturers' photos, Shutterstock, 123RF.

Design & typesetting: Profisatz.Graphics, Bianca Buhmann, Hamburg.
Printed on non-chlorinated, environmentally friendly paper.

Basic knowledge

Environmental engineering

The global water cycle: link between the environmental compartments

Approximately three quarters of the earth's surface is covered by water. The water on earth is part of a constant cycle, and passes through all aggregate states. The driving forces of this cycle are the sun and gravity. The water cycle connects the three environmental compartments of atmosphere (air), hydrosphere (water) and pedosphere (soil).

The solar radiation warms the water on the earth's surface and in the oceans. As a result, water evaporates and enters the atmosphere as water vapour, where eventually it forms clouds. The water returns to the earth's surface in the form of rain. About half of it then evaporates again. The vast majority of the remaining precipitation flows above the ground back into the oceans in the form of rivers. The remaining precipitation seeps into the ground, forming the groundwater. Most of the groundwater is returned to the oceans beneath the ground. The remainder exits the ground at above-ground sources and leads to the formation of rivers, which in turn flow back into the oceans above ground.

Humans withdraw water from the water cycle for different purposes, and return it to the cycle after use. Often the water is loaded with many contaminants when it is returned. As a result, the natural balance of the water cycle has been noticeably disturbed. For example, in many places the water seeping into the ground is no longer cleaned, but rather contaminated. The soil can no longer fulfil its natural cleaning function. Other examples of a negative influence on the global water balance include sealing formerly porous surfaces, deforestation and the depositing of hazardous waste in landfills.

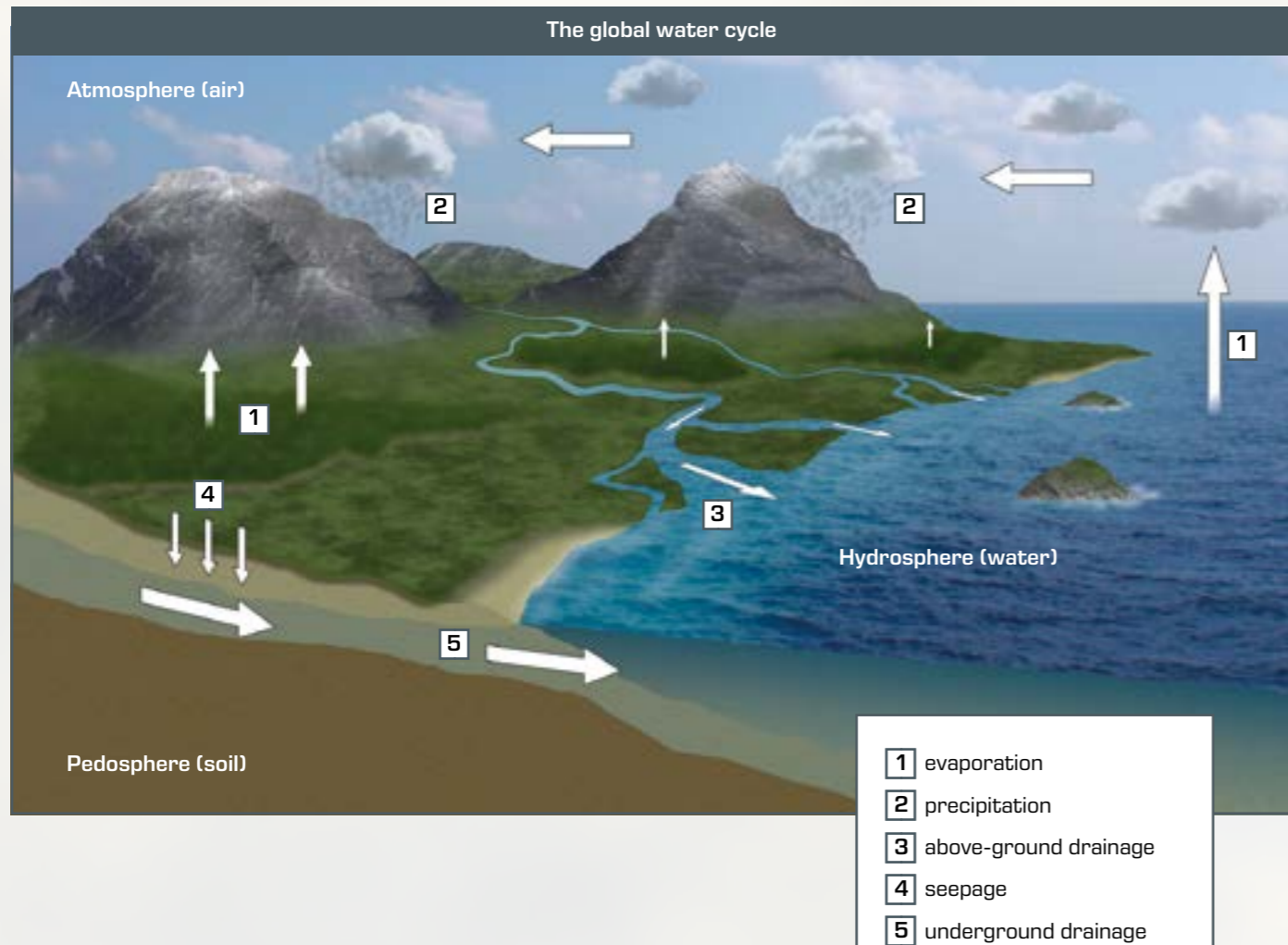

From "end-of-pipe" strategy to integrated environmental protection

For a long time people have been pursuing "end-of-pipe" strategies in order to counteract increasing environmental pollution. These strategies add downstream environmental protection measures to production processes, without involving the production processes themselves. Furthermore, water, air and soil were largely considered separately. However, it has been shown that this one-dimensional approach was inadequate considering the complexity of environmental sustainability. So for example, the fields of water and air often simply delayed the problem to the field of waste, such as the disposal of sludge from wastewater treatment.

Modern environmental protection concepts, however, adopt a holistic approach that includes all environmental sectors. Another goal today is to address the problems at an earlier stage of their development. Consequently, measures for environmental protection are now integrated into many production processes. The reuse of materials and the environmentally friendly use of energy play a central role here.

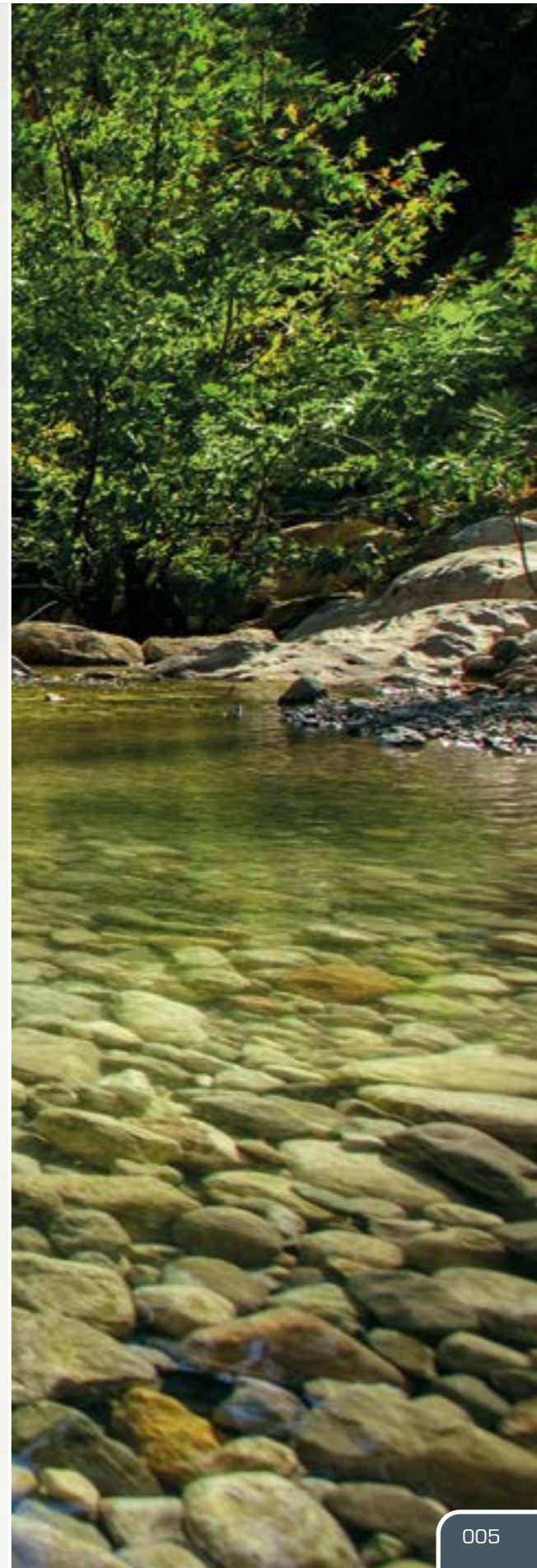
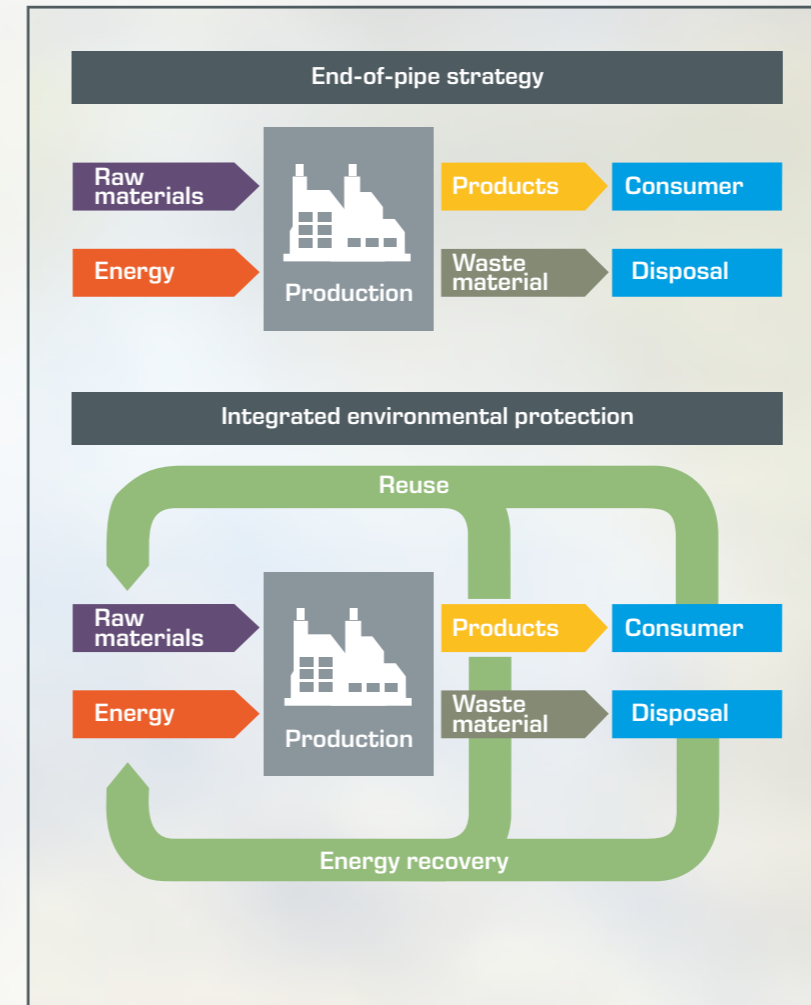

Subject areas

Environmental engineering

Water, air and soil: central components of teaching curricula

One of the biggest challenges is maintaining a clean environment. Once contaminants enter the environment, they do not necessarily remain at the site of contamination. Instead, the water cycle and winds mean these contaminants are transported worldwide. Contaminants can be transported and transformed in the atmosphere (air), hydrosphere (water) and pedosphere (soil). Understanding the complex processes in these three environmental compartments is essential for the development of modern environmental protection technologies.

Accordingly, sound knowledge of the basic relationships in the three environmental compartments of water, air and soil forms the foundation of environmental engineering professions. Since sustainable environmental protection also requires specialised and careful handling of waste, problems from the field of waste management are additional indispensable components of curricula in the field of environmental engineering.

Interdisciplinary thinking for holistic environmental protection

Our range of devices is generally structured in line with the generally accepted curricula in the field of environmental engineering. The devices have been developed by experienced engineers who have well-founded expertise thanks to their education, especially in the field of environmental engineering.

Environmental engineering is a relatively new engineering discipline. Many of the methods used in this area to protect the environment have their origins in other engineering disciplines. Thus, the methods used in water treatment and air pollution control are based on conventional process engineering. Similarly, groundwater flows in soils are also of course an integral part of hydraulics and hydraulic engineering.

This highlights the need for interdisciplinary thinking and action by aspiring engineers in the field of environmental engineering in order to face up to the complex challenges.

The devices presented in this catalogue represent a selection of teaching systems, which are a perfect complement to the theoretical basis for education in the field of environmental engineering. Most of these devices have their origins in other traditional fields of engineering. Similarly, you can find further, subject-related devices in our product range "Hydraulics for civil engineering" and "Process engineering".



Hydraulics for civil engineering



» Hydraulics for civil engineering



Process engineering



» Process engineering





Introduction	
Subject areas Water	010
Basic knowledge Wastewater treatment plant	012

Mechanical water treatment	
Basic knowledge Mechanical water treatment	014
HM 142 Separation in sedimentation tanks	016
CE 587 Dissolved air flotation	018
CE 588 Demonstration of dissolved air flotation	020
CE 579 Depth filtration	022

Biological water treatment	
Basic knowledge Biological water treatment	024
CE 705 Activated sludge process	026
CE 704 SBR process	030
CE 701 Biofilm process	032
CE 730 Airlift reactor	034
CE 702 Anaerobic water treatment	036

Physical/chemical water treatment	
Basic knowledge Physical/chemical water treatment	038
CE 583 Adsorption	042
CE 530 Reverse osmosis	044
CE 300 Ion exchange	045
CE 586 Precipitation and flocculation	046
CE 584 Advanced oxidation	048

Multistage water treatment	
Basic knowledge Multistage water treatment	050
CE 581 Water treatment plant 1	052
CE 582 Water treatment plant 2	054
CE 585 Water purification process	056

Subject areas
Water

The area of water focuses on water treatment. The aim of water treatment is always to remove specific substances from the water. This can be used to clean wastewater in a wastewater treatment plant prior to discharge into a body of water. From the perspective of environmental protection, the remediation of contaminated groundwater and landfill leachate is another broad application example. However, the aim of water treatment may also be to make water usable for a particular purpose, e.g. in the treatment of potable water.

Regardless of the application, there are a number of basic methods available to water treatment which are classically divided into three groups.

This section contains a teaching unit for each of the most important basic procedures, with which all important aspects of the respective method can be illustrated and taught in a clear and informative manner.

Water treatment plants are usually built in several stages and represent a combination of various basic processes. Therefore, we also offer two devices that enable you to illustrate the complexities of multistage water treatment.

Subject areas

Products

Unit operations of water treatment

Mechanical processes

HM 142
Separation in sedimentation tanks
CE 587
Dissolved air flotation
CE 588
Demonstration of dissolved air flotation
CE 579
Depth filtration

Biological processes

CE 705
Activated sludge process
CE 704
SBR process
CE 701
Biofilm process
CE 730
Airlift reactor
CE 702
Anaerobic water treatment

Physical/chemical processes

CE 583
Adsorption
CE 530
Reverse osmosis
CE 300
Ion exchange
CE 586
Precipitation and flocculation
CE 584
Advanced oxidation

Multistage water treatment

Combined
unit operations

CE 581
Water treatment plant 1
CE 582
Water treatment plant 2
CE 585
Water purification process

Basic knowledge

Wastewater treatment plant

Environmental protection through wastewater treatment

If untreated wastewater is discharged into a body of water, microorganisms destroy the organic matter contained in the water through high oxygen consumption. This leads to a lack of oxygen in the water, which in turn destroys the ecological balance. To prevent this from happening, wastewater must be treated in wastewater treatment plants beforehand. The most important component of a wastewater treatment plant is the biological purification by microorganisms. The natural degradation processes are thus shifted from the body of water into an industrial plant, where they take place in controlled and optimised conditions.

Mechanical treatment

First the wastewater is treated mechanically. The aim is to remove solids from the water. A bar screen first removes coarse solids such as textiles, paper and plastic bags from the wastewater. Then mineral solids such as entrained sand are separated in grit chambers by sedimentation. Organic solids, such as food scraps, are also separated by sedimentation in the primary clarification.



Biological treatment

After the mechanical treatment, the wastewater contains almost exclusively dissolved substances. These dissolved substances are biodegraded by microorganisms in the biological treatment. The most commonly used method here is the aerobic activated sludge process. In this treatment stage, the wastewater is aerated in order to supply the microorganisms (activated sludge) with oxygen. Since the activated sludge is suspended in the aeration tank, activated sludge is also continuously discharged along with the wastewater flow. In the secondary clarifier the activated sludge is discharged mechanically separated (usually by sedimentation) from the treated water. A portion of the separated activated sludge is fed back into the aeration tank as return sludge. Without return sludge, it would not be possible to achieve stable operation of the biological treatment. Although the secondary clarifier is actually a mechanical process, it is still therefore classed as a biological treatment.

Sludge treatment

The non-recycled portion of the sludge separated in the secondary clarifier is referred to as surplus sludge or secondary sludge. Surplus sludge and sludge from the primary clarification (primary sludge) mainly contain organic ingredients and are a by-product of wastewater treatment. Therefore, a separate treatment is required for this sludge (sewage sludge). This is usually implemented in digestion towers, where the sewage sludge is digested under anaerobic conditions. Digested sludge can then be used as fertiliser in agriculture, for example.



Basic knowledge

Mechanical water treatment

Solids can easily lead to blockages in plant components such as pipes, valves and fittings. In multistage water treatment plants the first stage is usually to remove solids by mechanical means for this reason. In mechanical processes, the solids are not altered either physically or chemically. Only separation of the solids from the liquid phase (water) takes place. This can be implemented according to the following three principles:

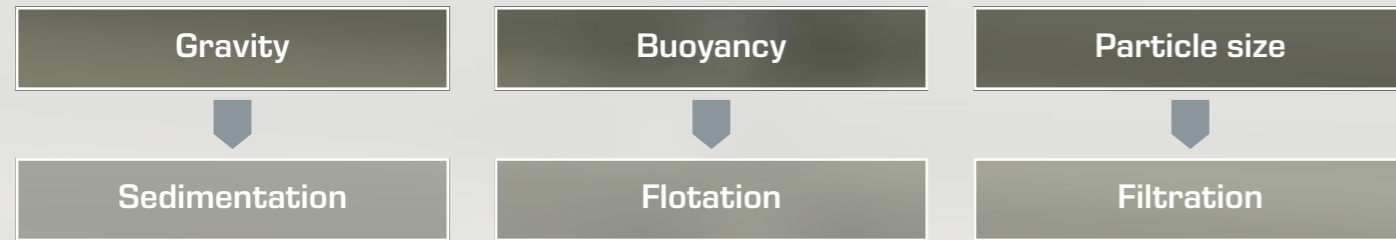

Sedimentation

The easiest way to separate solids is by sedimentation. In the sedimentation tank, the solid particles fall to the bottom due to gravity and can then easily be removed with sludge scrapers. Effective sedimentation requires calm flow conditions in the sedimentation tank (no turbulence). Sedimentation is mainly used in wastewater treatment plants in primary clarification and secondary clarification.

Filtration

During filtration, the solids are retained by porous filter media. Effective filtration requires that the filter medium is only permeable for the liquid phases (water), but not for the solids. The success of treatment depends on the particle size of the solids in relation to the pore size of the filter medium. A basic distinction is made between surface filtration and depth filtration.

In **surface filtration**, the solids do not penetrate the filter medium, but instead are retained on its surface (sieve effect). In **depth filtration**, however, the wastewater penetrates the filter medium (e.g. fixed bed of sand or gravel). The solids are retained in the pores between the individual sand grains, whereas the water flows through the fixed bed unimpeded (filtrate). As the load of the fixed bed increases, the pressure drop increases and the flow rate decreases. A backwash cleans the fixed bed again, so that the pressure drop decreases.

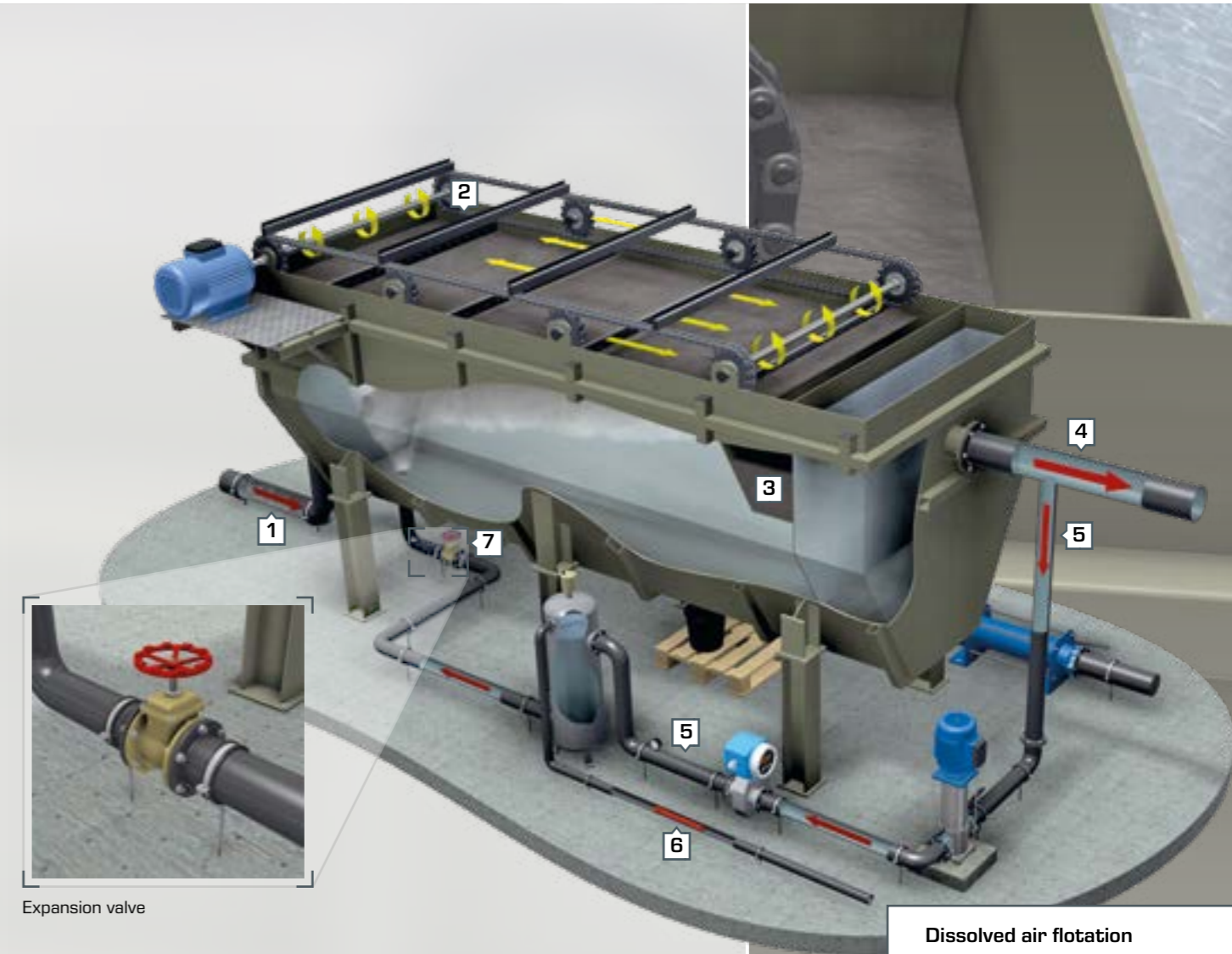
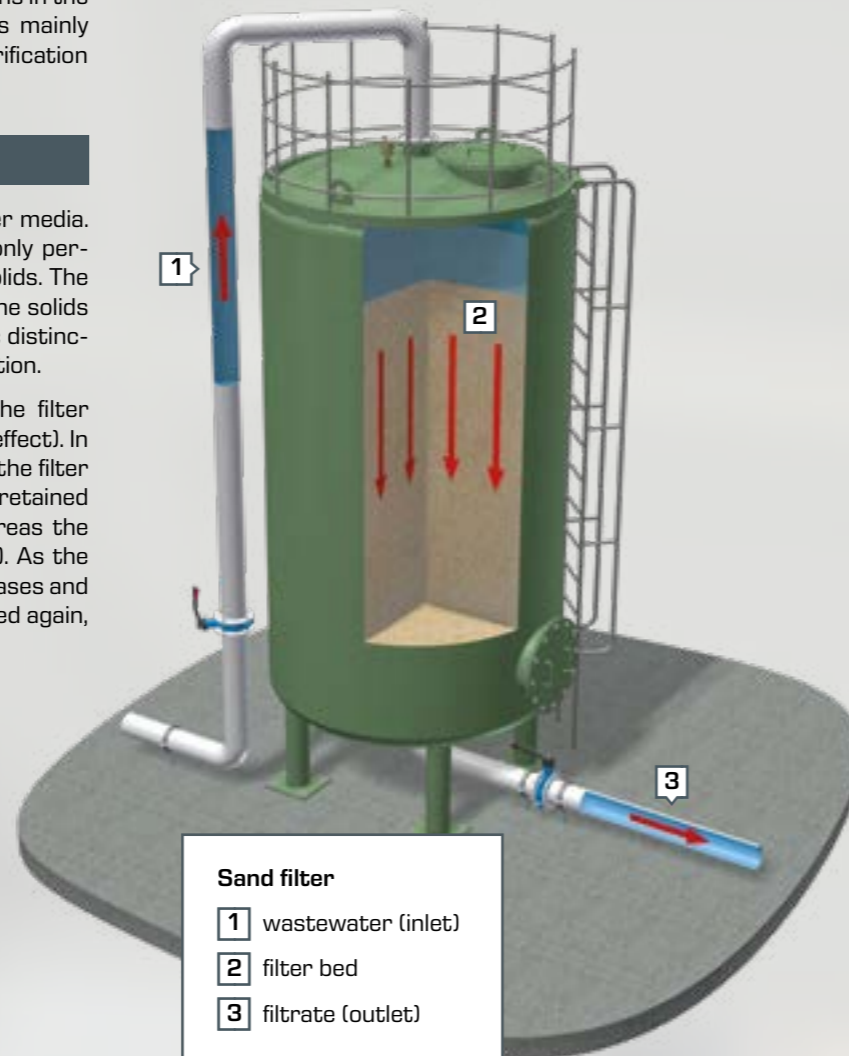

Flotation

Solids with low settling velocities cannot be effectively separated by sedimentation because this would require very large sedimentation tanks. In this case, flotation processes provide a sensible alternative. The basic principle is still the same. Gas bubbles attach themselves to the bottom of the solids and drive the solids to the surface. Once there, the floated solids can be removed with special scrapers. Flotation processes differ mainly in the way the gas bubbles are produced.

In water treatment, the most commonly used method is dissolved air flotation. In this process, a partial flow of the treated water is saturated with air under pressure. The air-saturated water is then passed back to the inlet region of the flotation tank (circulation). An expansion valve is located just before the inlet to the flotation tank, which causes the water to suddenly re-expand to atmospheric pressure. This expansion causes the dissolved air to form fine bubbles.

Dissolved air flotation

- 1 wastewater
- 2 sludge scraper
- 3 separated sludge
- 4 treated water
- 5 circulation
- 6 compressed air
- 7 expansion valve

HM 142 Separation in sedimentation tanks

Sedimentation is the easiest way to separate solid particles from a liquid phase. Therefore this process is very common in water treatment. This device can be used to clearly teach the basics of this separation process. The main focus is on determining the maximum possible hydraulic surface loading.

We have placed great importance on visual observation of the sedimentation process. Therefore mainly transparent materials are used. Furthermore, the sedimentation tank is fitted with lighting.

The raw water is produced by mixing a concentrated suspension with fresh water. Depending on the mixing ratio, a raw water with the desired solids concentration is obtained. A stirring machine in the inlet area of the sedimentation tank prevents the solids from settling before entering the experiment section. The water level in the sedimentation tank can be adjusted continuously.

The device is completed by a lamella unit, which you can optionally place in the sedimentation tank. White and black lamellas are available, depending on the colour of the contaminants used.

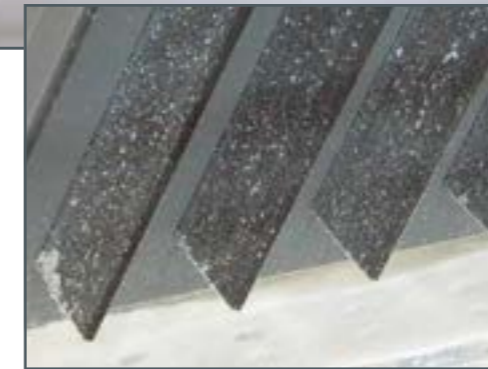

The sedimentation process and the flow conditions can be observed very clearly thanks to the use of transparent materials and lighting.



Optional lamella unit

About the product:



🎓	Learning objectives
■	basic principle for the separation of solids from suspensions in a sedimentation tank
■	determine the hydraulic surface loading
■	influence of the following parameters on the separation process: <ul style="list-style-type: none"> ▶ concentration of solids ▶ flow rate ▶ flow velocity in the inlet ▶ water level in the sedimentation tank
■	investigation of the flow conditions
■	how lamellas affect the sedimentation process

CE 587 Dissolved air flotation

Removal of solids by flotation

Flotation, alongside sedimentation, is another process often used in water treatment to remove solids. Dissolved air flotation is the most commonly used flotation process.

Experiments with great practical relevance

Our CE 587 teaching unit allows you to study all important aspects of this process. In order to create high practical relevance, we have placed great emphasis on the highest possible realism in the development of this device.

The device consists of a supply unit and a trainer. First, the raw water is pre-treated by flocculation. Then the flocs are transported to the surface of the water in the flotation tank by means of small air bubbles. An electrically driven scraper allows you to clear the water surface of the floating substances. Many of the components used, such as electromagnetic flow rate sensors and metering pumps, are also used in large-scale industrial plants. By using transparent materials you can optimally observe all the stages in the process.

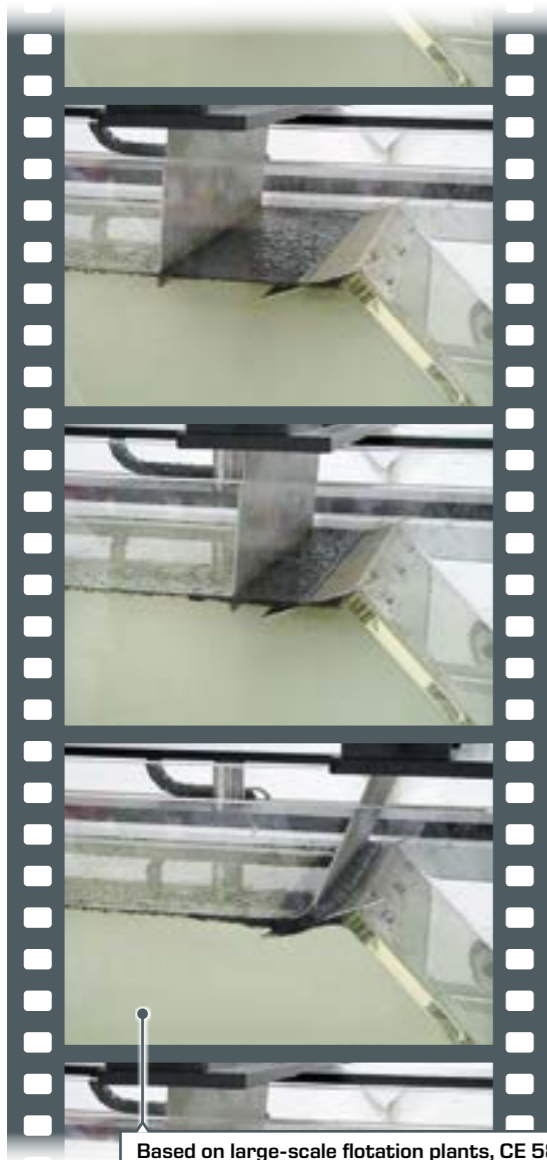

Based on large-scale flotation plants, CE 587 is equipped with an electrically driven scraper which removes the floated solids from the surface of the water.

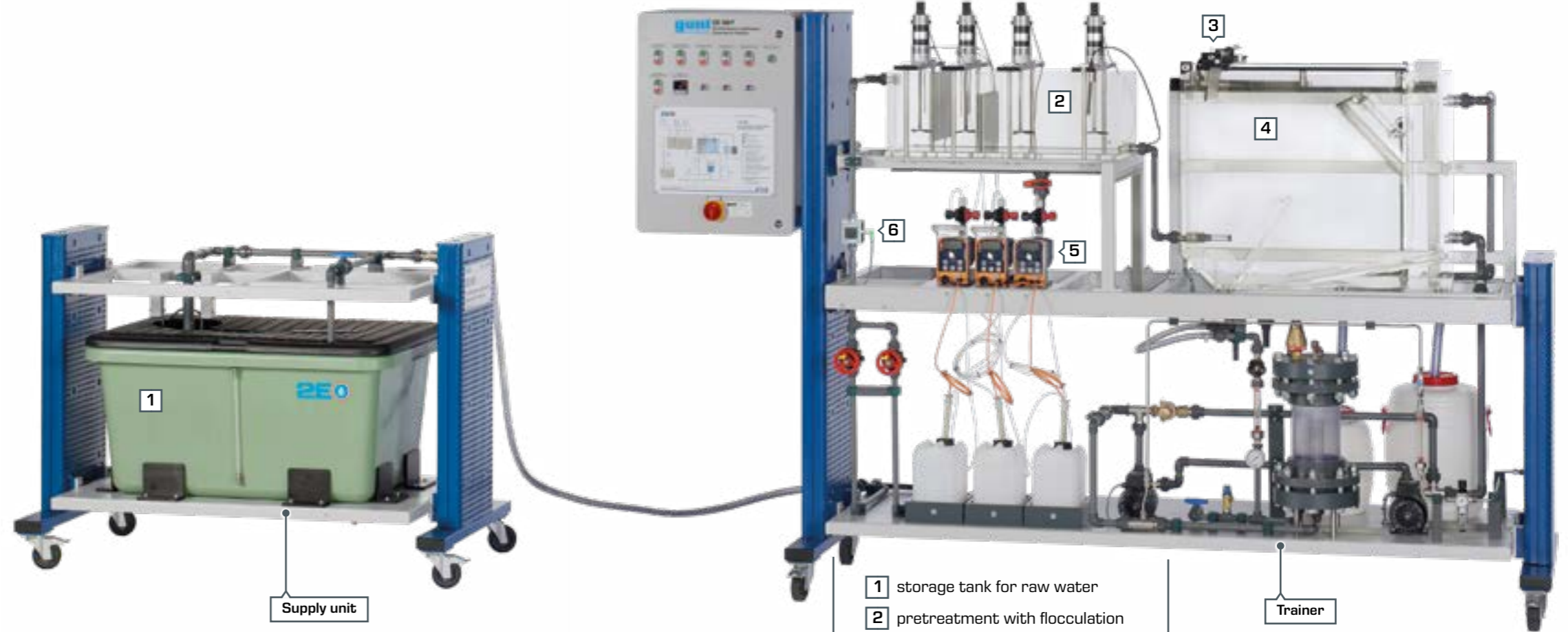

- 1 storage tank for raw water
- 2 pretreatment with flocculation
- 3 electrically driven scraper
- 4 flotation tank
- 5 metering pumps
- 6 electromagnetic flow meter

Trainer

Supply unit



Standard at GUNT: use of high-quality industrial components such as professional metering loading rate (rising velocity) pumps

Learning objectives
■ functional principle of dissolved air flotation
■ creation of a stable operating state
■ effects of the coagulant and flocculant concentration
■ determination of the hydraulic loading rate (rising velocity)

About the product:



CE 588 Demonstration of dissolved air flotation

Dissolved air flotation clearly demonstrated

During flotation, the solids to be separated are transported to the water surface by small gas bubbles. The most commonly used process is the dissolved air flotation. The basis of this process is that the solubility of air in water increases with increasing pressure.

This compact trainer focuses on the basic function and visualisation of the process. Therefore, we have used transparent materials and attached great importance to easy-to-use components. Our CE 587 teaching system is also characterised by its practical relevance.

The undissolved contaminants are separated in a vertical flotation column. A water circuit is connected to the flotation column. At the highest point of the circulation there is negative pressure. The required air for the flotation is sucked in by opening a

valve located at this point. Under pressure, the air dissolves in the water and, after the water has been depressurised in the lower part of the flotation column, the air forms small bubbles. A pressure vessel filled with Pall rings ensures a sufficiently long retention time to dissolve the air and to separate undissolved air before entering the flotation column.

Of course you also receive comprehensive instructional material for this device that quickly helps you become familiar with operation.

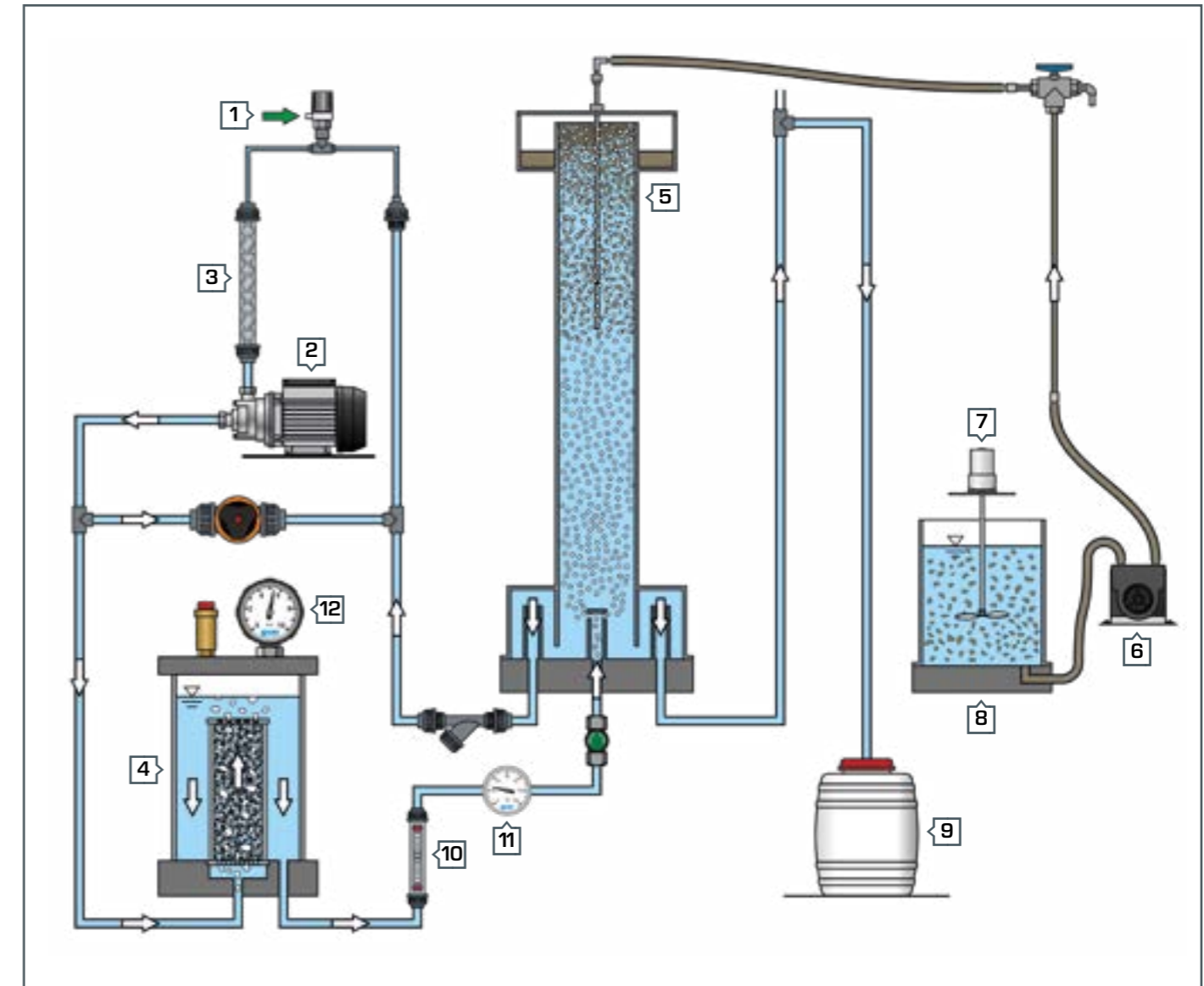
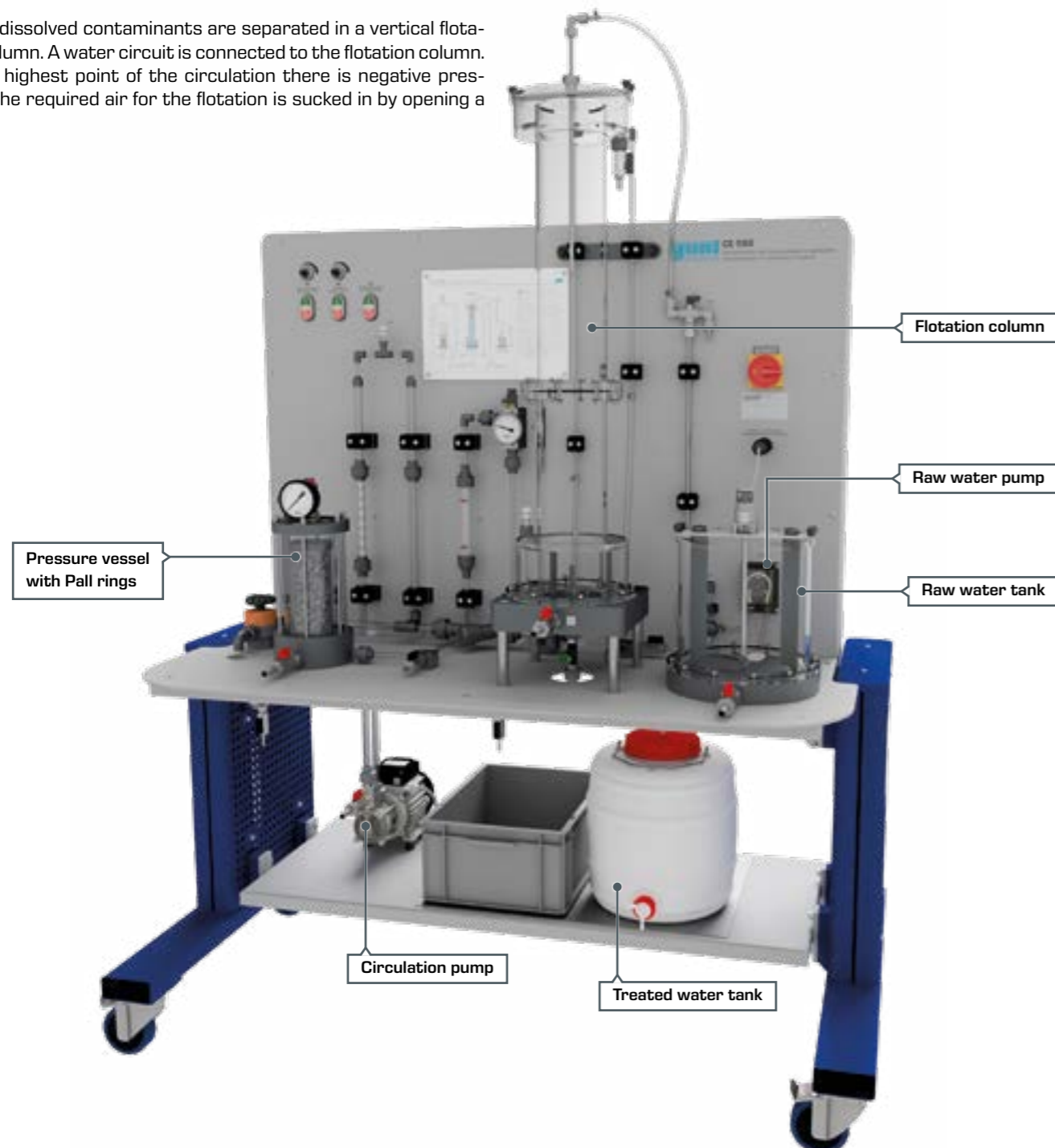

- | | |
|--------------------|----------------------|
| 1 air | 7 stirring machine |
| 2 circulation pump | 8 raw water tank |
| 3 static mixer | 9 treated water tank |
| 4 pressure vessel | 10 flow meter |
| 5 flotation column | 11 thermometer |
| 6 raw water pump | 12 manometer |

Learning objectives

- how dissolved air flotation works
- dissolving gases in liquids:
 - Henry's law
 - Dalton's law

About the product:



CE 579

Depth filtration

Depth filtration: indispensable in water treatment

Depth filtration is an important and frequently used process step in water treatment. Exact knowledge of the principle of operation and the characteristics of this process are an indispensable component in the education of budding engineers and specialist technicians.

The educational focus of this trainer is the investigation of the pressure conditions. In order to measure the pressures, the filter is fitted with a differential pressure measurement and several pressure sensors along the filter bed.

The trainer is controlled via the integrated PLC with touch screen. By means of an integrated router, the trainer can alternatively be operated and controlled via an end device. The user interface can also be displayed on additional end devices (screen mirroring). Via the PLC, the measured values can be stored internally. Access to stored measured values is possible from end devices via WLAN with integrated router/LAN connection to the customer's own network.



About the product:

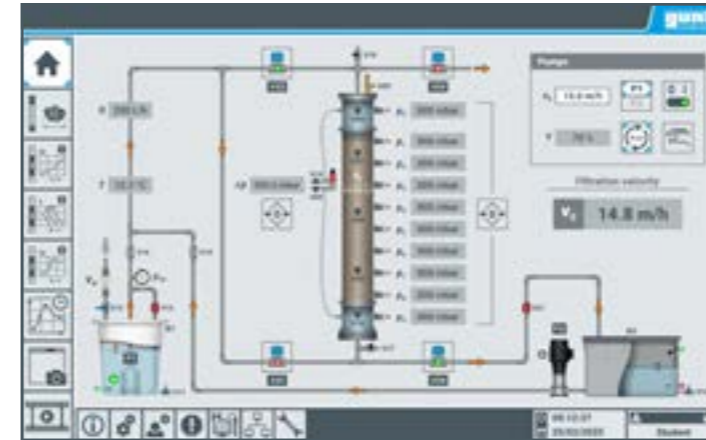

Touch screen: process schematic



Electrically-driven ball valve



Frequency converters for controlling the pumps

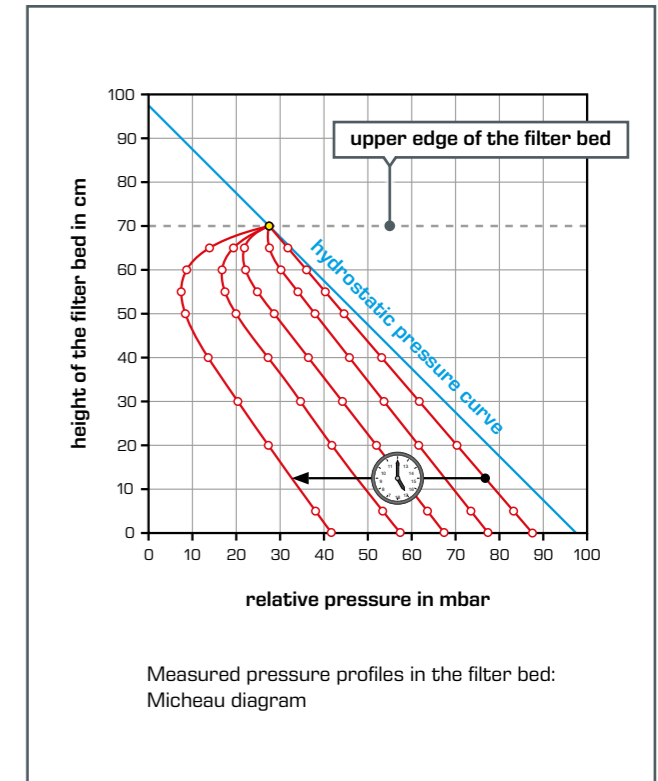

Measured pressure profiles in the filter bed:
Micheau diagram



Transparent filter tube to observe the increased loading of the filter bed

Learning objectives	
■	pressure conditions in a filter
■	factors influencing the pressure loss (Darcy's law) <ul style="list-style-type: none"> ▶ flow rate ▶ height of the filter bed ▶ permeability of the filter bed
■	determine the pressure in the filter bed (Micheau diagram)
■	backwash of filters <ul style="list-style-type: none"> ▶ observe the fluidisation process ▶ determine the expansion of the filter bed ▶ determine the required flow velocity (fluidisation velocity)

Basic knowledge
Biological water treatment

Microorganisms clean wastewater

The aim of biological wastewater treatment is the elimination of organic, biodegradable materials. This elimination is carried out by microorganisms which use organic substances as a source of food. This biodegradation also causes a conversion of materials to take place. This is a significant advantage that biological processes have over other methods. In adsorption, for example, it is simply a matter of displacing the substances to be removed from the wastewater onto the adsorbent (mass transport). Biodegradation may occur under either aerobic or anaerobic conditions. A number of methods are available in order to bring the wastewater to be treated into contact with the microorganisms (biomass). Regardless of whether the degradation is carried out aerobically or anaerobically, a distinction is made between the following two principles:

Suspended biomass

The biomass is present in the form of small flocs (activated sludge). The activated sludge is suspended in the wastewater.

Sessile biomass

The biomass is fixed on surfaces of solid bodies as a biofilm. The wastewater runs away over the biofilm as a thin film.

Aerobic activated sludge process

The aerobic activated sludge process is the most widely used biological wastewater treatment process. The biomass is a suspended activated sludge in the aeration basin through which the wastewater flows continuously. The wastewater is also aerated here in order to supply the microorganisms with oxygen. Biomass (activated sludge) also continuously leaves the aeration tank along with the wastewater flow. Therefore, the discharged

activated sludge must be separated from the treated wastewater in a secondary clarifier (usually by sedimentation). Part of it is fed back into the aeration tank (return sludge). The non-recycled fraction is referred to as surplus sludge and is a waste product of this process.

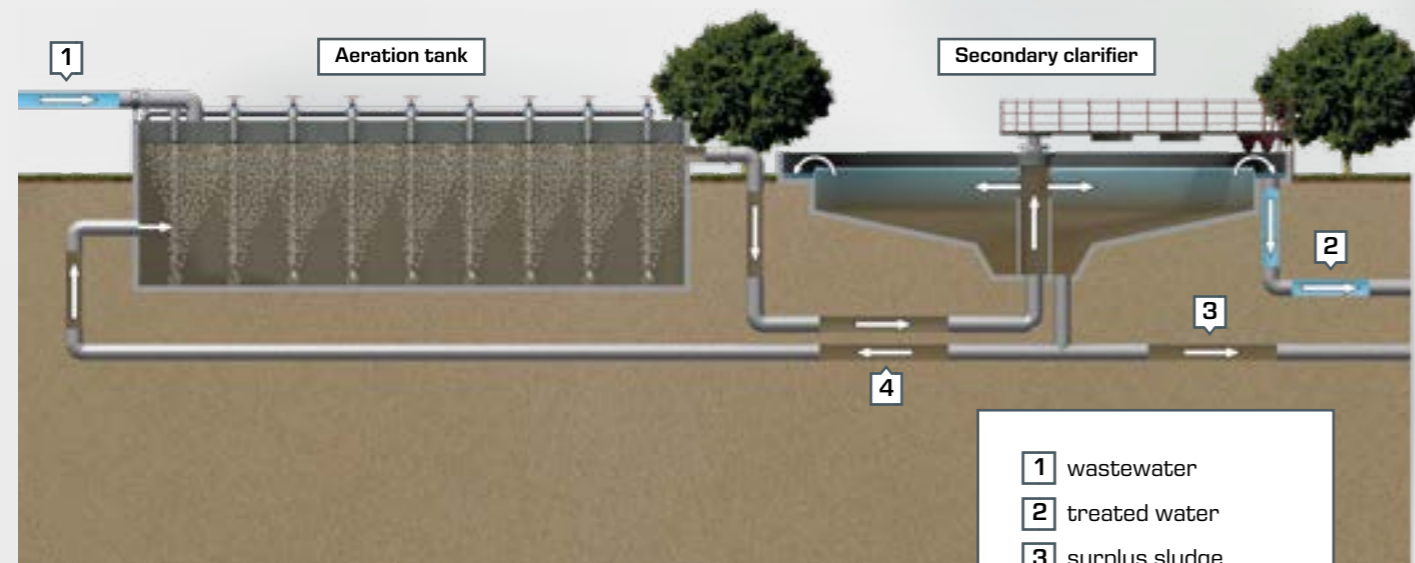

Fundamental principle of the aerobic activated sludge process

- 1 wastewater
- 2 treated water
- 3 surplus sludge
- 4 return sludge

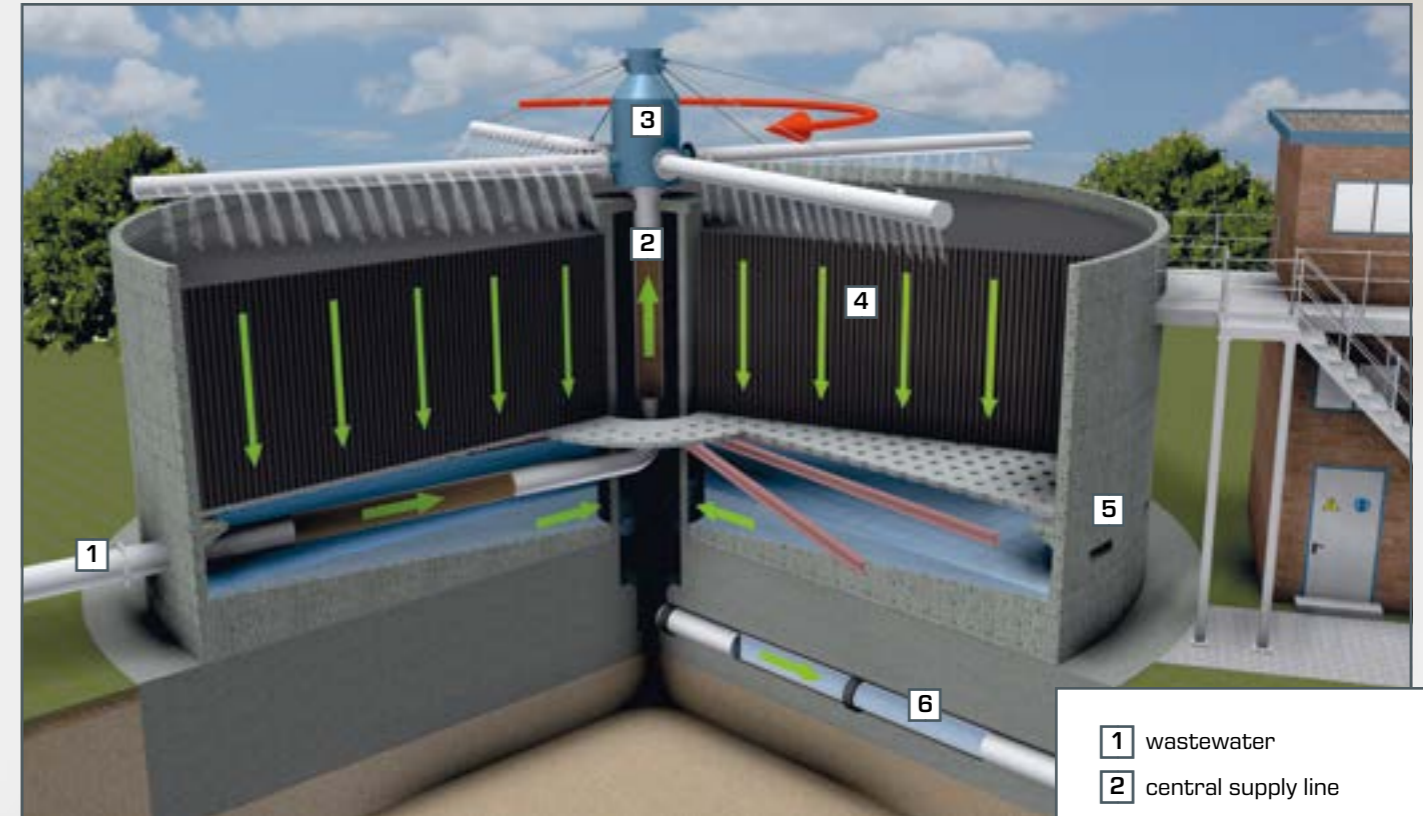

Design and function of a trickling filter

- 1 wastewater
- 2 central supply line
- 3 rotary distributor
- 4 fixed bed with biofilm
- 5 aeration openings
- 6 treated water

Trickling filters

Trickling filters are an aerobic biofilm process. In this process, a rotary sprinkler spreads the wastewater evenly over a fixed bed. The fixed bed consists of special support material on the surface of which a thin layer of microorganisms (biofilm) forms. While the wastewater trickles through the fixed bed, the microorganisms clean the wastewater by biological processes. Trickling filters usually have an open design and offer lateral openings below the fixed bed. This allows aeration by natural convection (chimney effect). Energy-intensive artificial aeration, such as that used in the activated sludge process, is not necessary.

Anaerobic processes

Anaerobic processes are particularly suitable for industrial wastewater, which is often heavily contaminated with organic substances (e.g. food industry). There is a variety of different processes or reactor types available for this purpose. Under anaerobic conditions, the degradation of organic matter creates biogas, which consists mainly of methane. Biogas can be used, for example, with combined heat and power plants to generate electricity. This is a positive secondary aspect of anaerobic wastewater treatment and clearly illustrates the close inter-connection of issues from the field of energy and environment.

CE 705 Activated sludge process

A laboratory-scale wastewater treatment plant

The aerobic activated sludge process is the most widely-used biological process in wastewater treatment plants worldwide. Sound knowledge of this process is therefore essential for budding engineers and specialist technicians in the field of environmental engineering.

This device has been designed by experienced engineers with the aim of being able to clearly teach the complex processes involved in this process in continuous operation in a practical manner. The device is designed for carbon elimination and nitrogen elimination. The nitrogen is removed by nitrification and pre-denitrification. To this end, the aeration tank is divided into an aerobic and an anoxic area.

The device consists of a separate supply unit with a large storage tank for wastewater and a trainer. All process-relevant components are located on the trainer. This includes in particular the aeration tank and secondary clarifier.

You can adjust all process-relevant parameters in order to investigate their influence on the cleaning process. The control of the trainer is realised by the integrated PLC via touch screen. By means of an integrated router, the trainer can alternatively be operated and controlled via an end device. The user interface can also be displayed on additional end devices (screen mirroring).

- laboratory-scale wastewater treatment plant
- continuous operation
- nitrification
- pre-denitrification
- device control using an integrated PLC
- integrated router for operation and control via an end device and for screen mirroring on additional end devices: PC, tablet, smartphone



Touch screen: process schematic



Touch screen: operation of the pumps

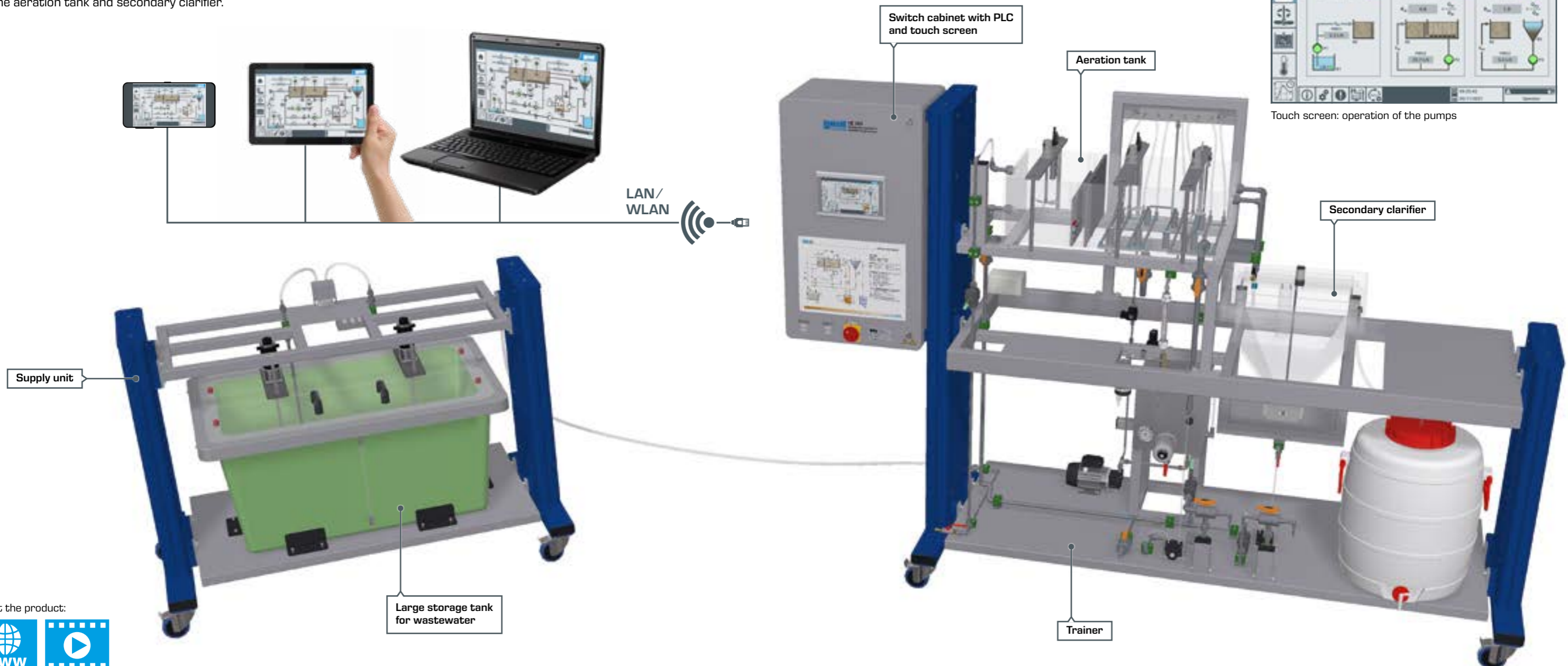

About the product:



CE 705 Activated sludge process

Instrumentation and control technology

Nowadays, complex processes such as the activated sludge process are largely automated. The use of modern instrumentation and control technology is indispensable for this purpose. This also requires that engineers in the field of environmental engineering have at least basic knowledge of such systems.

To prepare students for the challenges of professional practice, we have also observed this important aspect when developing the device. CE 705 is therefore equipped with extensive instrumentation for measurements and a PLC with touch screen.

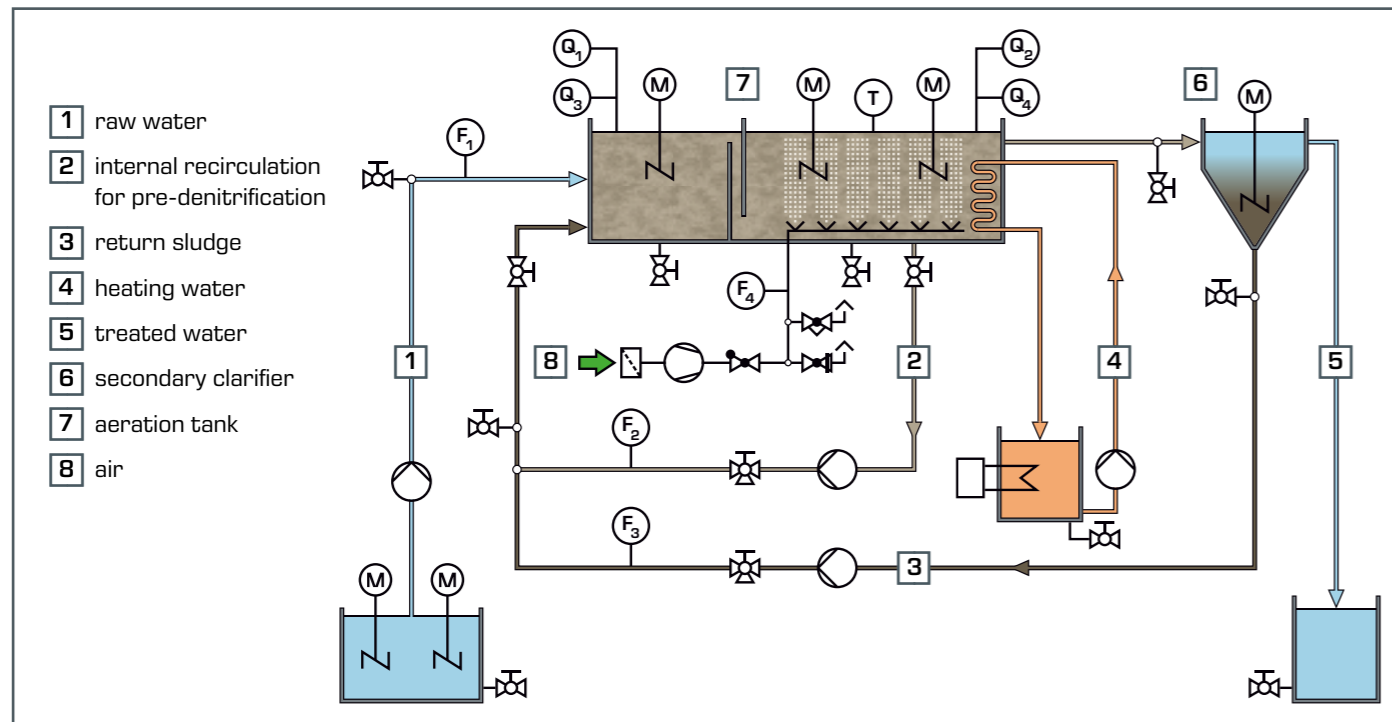

Instructional material

You also receive comprehensive instructional material about this device, which quickly helps you become familiar with its operation. In addition, the theoretical fundamentals of the activated sludge process are clearly represented in detail.



Commissioning and training

CE 705 is used in many educational institutions worldwide. Commissioning and training for customers is carried out by expert GUNT employees. In addition to testing the delivered products, GUNT technicians provide in-depth instruction to the customer on operation of the devices. This allows you to quickly incorporate the teaching system in your classroom.

Learning objectives

- functional principle of nitrification and pre-denitrification
- creation of a stable operating state
- identification of the following influencing factors
 - ▶ sludge age
 - ▶ volumetric loading
 - ▶ sludge loading
 - ▶ return sludge ratio
 - ▶ return ratio of the internal recirculation (denitrification)
- efficiency of the pre-denitrification
- influence of the following ambient conditions to the biological degradation
 - ▶ temperature
 - ▶ oxygen concentration

Measured variables			Auto
flow rate	F ₁	raw water	☑
	F ₂	internal recirculation	☑
	F ₃	return sludge	☑
	F ₄	aeration	
oxygen concentration	Q ₁	denitrification area	
	Q ₂	nitrification area	☑
pH value	Q ₃	denitrification area	
	Q ₄	nitrification area	
temperature	T	nitrification area	☑

Auto control

About the product:



After successful commissioning and training, a GUNT employee hands over CE 705 to Mrs. Professor Dr.-Ing. Deininger of the Deggendorf Institute of Technology (Germany).

TECHNISCHE HOCHSCHULE DEGGENDORF THD

Modern and practical training – supported by high-quality educational systems from GUNT

CE 704 SBR process – Sequencing Batch Reactor

Discontinuous wastewater treatment

In the classic continuous activated sludge process, the individual process steps of biological treatment take place simultaneously and separately from each other. In contrast, in the SBR process these process steps take place sequentially in one tank. Treatment of the wastewater is therefore not continuous, but in batches. Accordingly, this type of reactor is called a Sequencing Batch Reactor (SBR).

At the beginning of a cycle, the reactor is filled with wastewater. This is followed by mixing and aeration phases. This sets the environment required for each process step. After a defined period of time, all stirring machines and aeration are switched off. This causes the activated sludge to sink to the bottom of the reactor. After completion of the sedimentation phase, the treated wastewater is pumped out of the reactor so that a new cycle can begin. The duration and arrangement of the individual phases can vary within a cycle. Only the sedimentation of the activated sludge and the withdrawal of the treated water are obligatory at the end of a cycle.

This teaching device is used to learn the basics of the SBR process in a practical way. The main component of the device is the reactor, which is equipped with a stirring machine and an aeration device. The stirring machine ensures sufficient mixing of the reactor contents even in phases without aeration (denitrification).

Using timers, you can individually set the aeration and mixing phases. The oxygen concentration, pH value and temperature in the reactor are recorded. A digital process controller continuously displays the measured values and the speed of the stirring machine. The process controller also functions as a controller for the oxygen concentration during the aeration phase. The process controller is very easy to use and is operated by means of a touch screen.

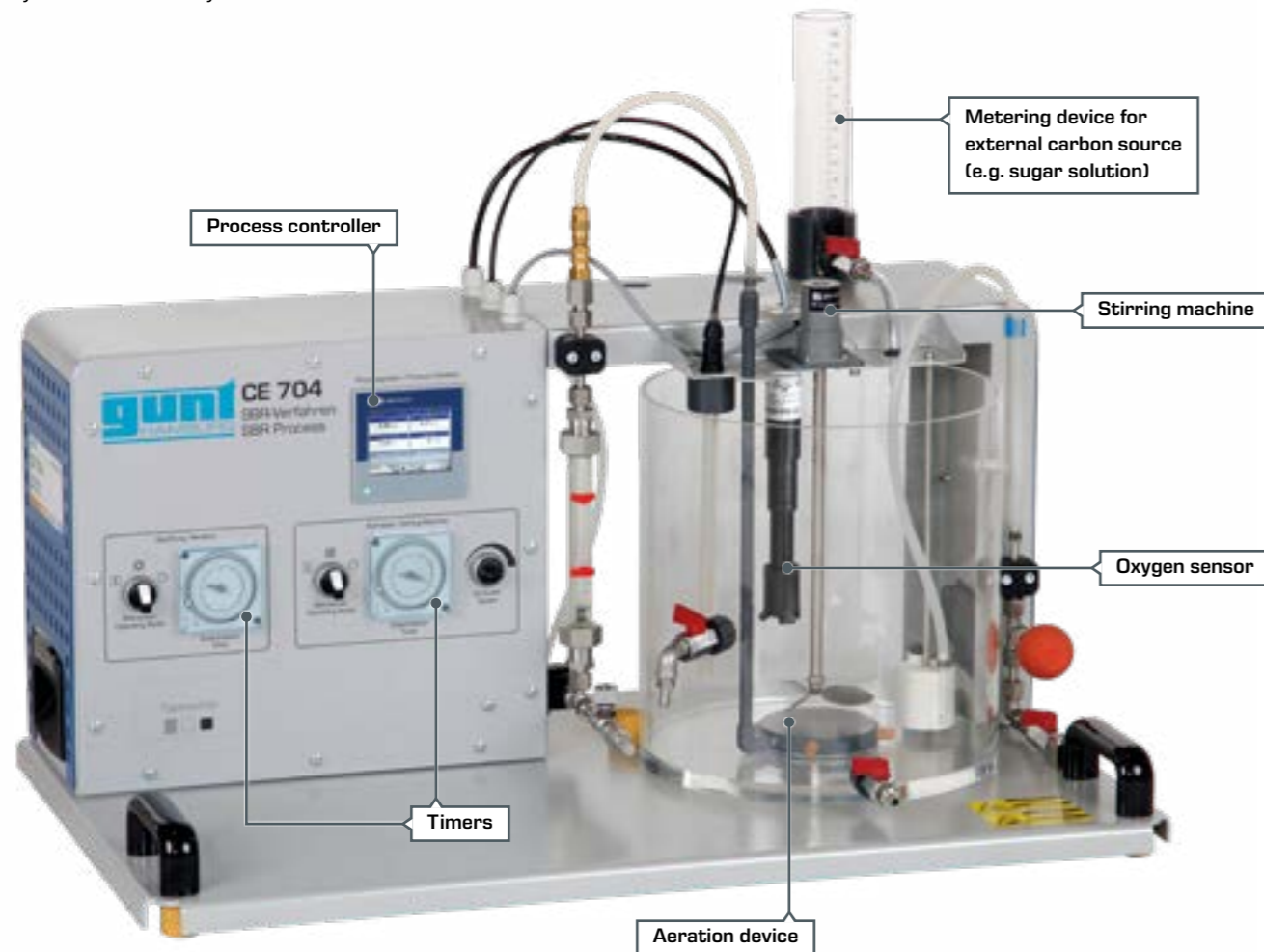

About the product:

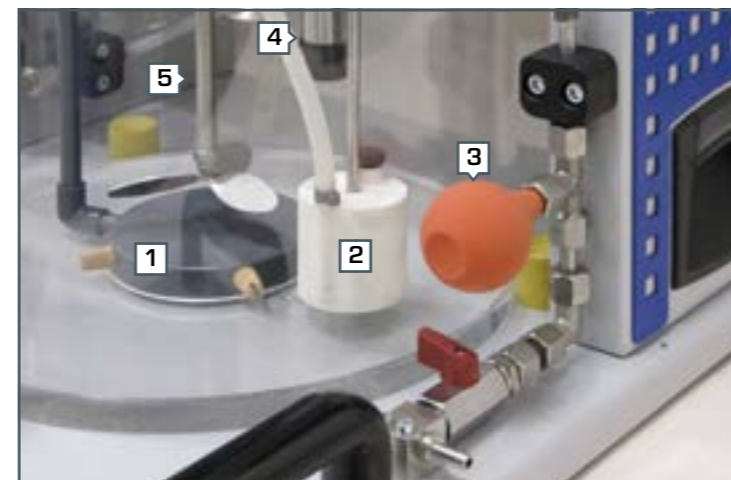
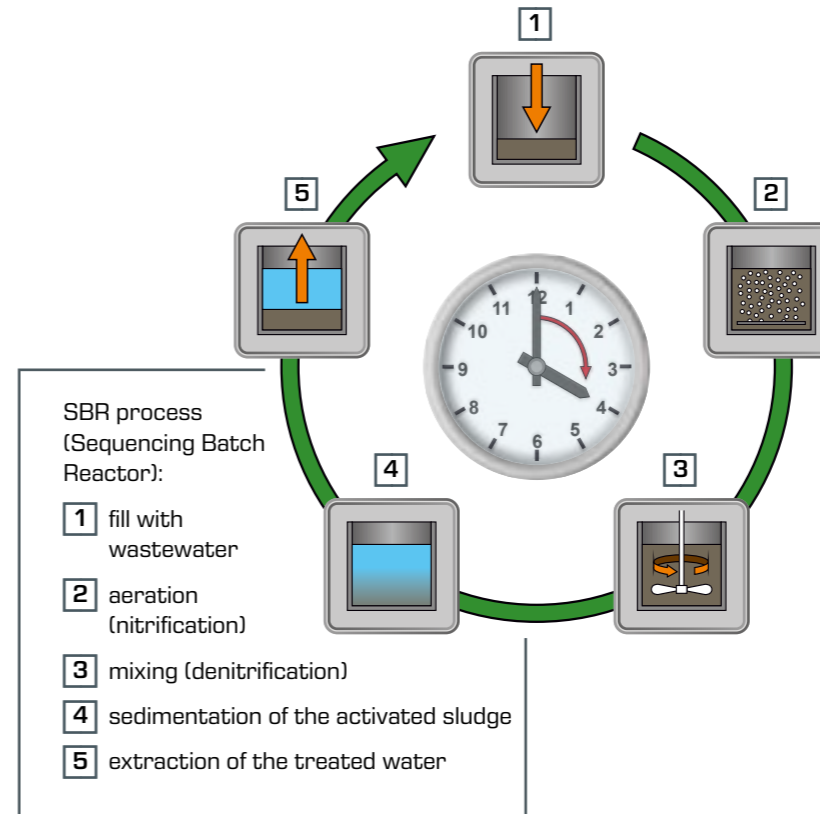

- 1 aeration device
- 2 floating device for clear water extraction
- 3 suction ball for clear water
- 4 oxygen sensor
- 5 stirring machine



Digital process controller for displaying the process variables and for controlling the oxygen concentration

Learning objectives
<ul style="list-style-type: none"> functional principle of the SBR process elimination of nitrogen by nitrification and denitrification influence of cycle design on treatment results recording and interpretation of temporal concentration curves determining conversion rates sedimentation properties of activated sludge

CE 701

Biofilm process – laboratory-scale trickling filter

Trickling filters: an aerobic biofilm process

Although trickling filters are one of the oldest biological wastewater treatment processes, they are still widely in use. The trickling filter process is therefore still an integral part of the curriculum in the field of water treatment.

The CE 701 trickling filter is designed for carbon elimination and nitrification. A rotary distributor distributes the wastewater to be treated evenly over the fixed bed. You can adjust the speed of the rotary distributor. There are two different HDPE packing types available for the fixed bed. The packing differs in terms of the specific surface area.

The trickling filter of CE 701 has aeration vents below the fixed bed. This allows for aeration by natural convection. If necessary, you can also close the aeration vents to artificially aerate the trickling filter with a compressor.

The instructional material sets out the fundamentals and design of trickling filter plants in detail. A detailed description of the device and the experiments enables you to quickly incorporate this training system into your classroom.

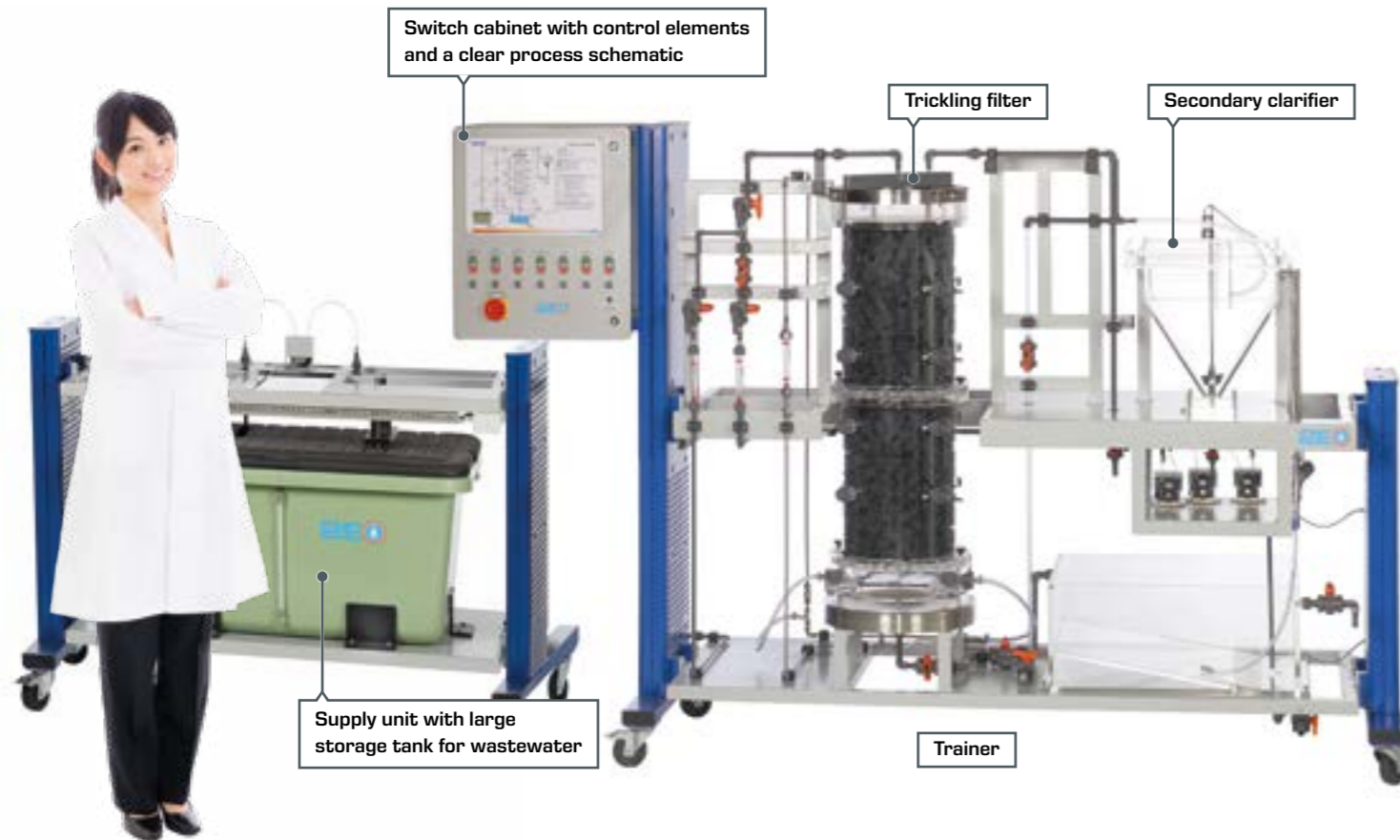

Rotary distributor on the head of the trickling filter with variable speed adjustment



Sampling point within the trickling filter

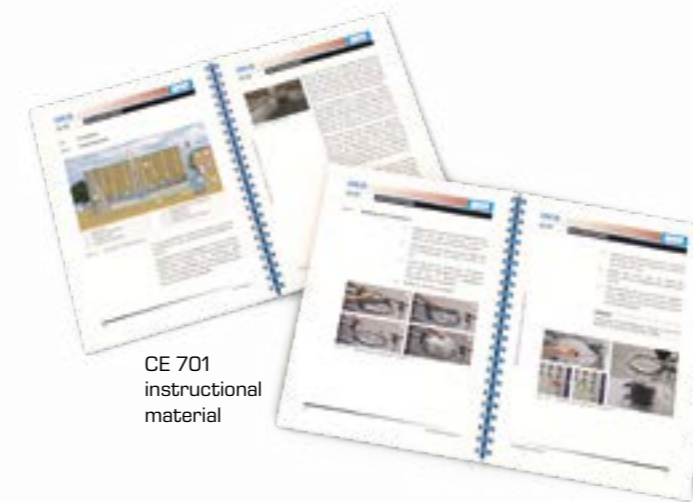

CE 701
instructional
material

Concentration profiles

Sampling points are located within the fixed bed. This allows you to determine the concentration profiles of BOD₅, ammonia and nitrate which are characteristic for trickling filters.

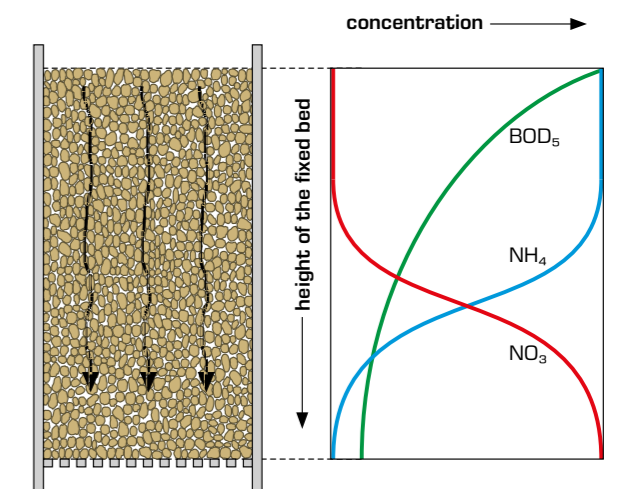

Typical concentration profiles of BOD₅, ammonia (NH₄) and nitrate (NO₃) in a trickling filter

About the product:



Learning objectives

- functional principle of a trickling filter
- recording of concentration profiles
- creation of a stable operating state
- identification of the following influencing factors
 - ▶ flow rate of recirculation
 - ▶ volumetric loading of the trickling filter
 - ▶ surface loading of the trickling filter
- comparison of various packing types

CE 730 Airlift reactor

Powerful bioreactors

Supplying the microorganisms (biomass) with oxygen is of crucial importance for the performance of an aerobic bioreactor. Another important aspect is uniform mixing of the reactor contents. Airlift reactors meet both of these challenges to a particular degree.

In an airlift reactor mixing occurs exclusively through the aeration, which is necessary anyway. Mechanically moving parts (e.g. stirring machines) are not necessary. The retention of the biomass in the reactor required for effective operation is achieved by circulation. Airlift reactors are used in biotechnology and in biological wastewater treatment.



Airlift reactor CE 730

The educational focus is the functional principle and operation of an airlift reactor. These mainly include releasing oxygen in the liquid phase (water) and determining the flow conditions in the reactor.

The core of the trainer is an airlift reactor with external circulation. There are several different distributors available for aeration of the reactor. This allows you to study how bubble size influences mass transfer. Two measuring points for conductivity are located on the circulation at defined intervals. Adding a salt solution causes a sharp increase (peak) in conductivity at both measurement points, with some delay between them. The time difference between the two peaks and the distance between the measuring points can be used to determine the flow velocity in the reactor.



Airlift reactor during a test run

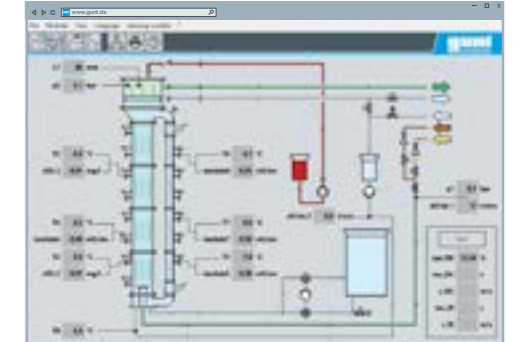

Software

The clearly-arranged software included with CE 730 continuously displays all key process variables. You can of course save the measured values for analysis.



Various distributors for aerating the reactor

Learning objectives

- influence of the superficial gas velocity on:
 - ▶ gas content
 - ▶ mass transfer coefficient
 - ▶ mixing time
 - ▶ superficial fluid velocity

About the product:



CE 702 Anaerobic water treatment

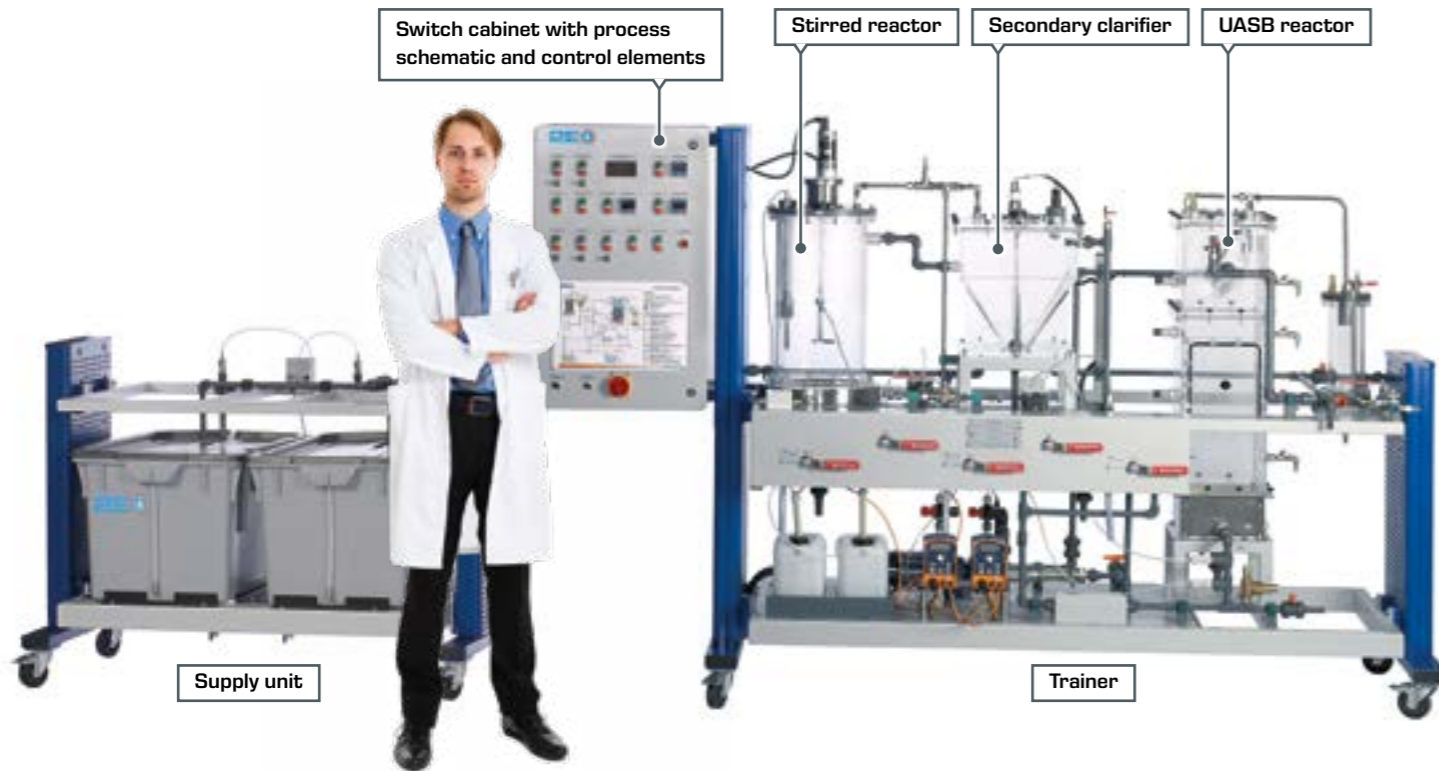

Anaerobic processes are primarily used for wastewater which is highly contaminated with organic substances, such as those occurring in the food industry.

Our CE 702 teaching unit offers you two different methods. These are the anaerobic activated sludge process and the UASB process. You can operate both processes separately (1-stage) or in series (2-stage). This gives you a total of three different modes of operation. The device is also equipped with extensive instrumentation and control technology and software.

You also receive comprehensive instructional material on this device that quickly helps you become familiar with operation of the device. In addition, the theoretical fundamentals of anaerobic wastewater treatment are clearly represented in detail.

The 2-stage operating mode allows you to control the pH and the temperature independently of each other in both stages. This type of process control has proven itself in practice and has the advantage of being able to better adapt the environmental conditions to the needs of each of the degradation steps. The device is equipped with gas collecting pipes, which can be used to take gas samples from the system for analysis.

About the product:



Operating mode 1 (1-stage)	
Operating mode 2 (1-stage)	
Operating mode 3 (2-stage)	

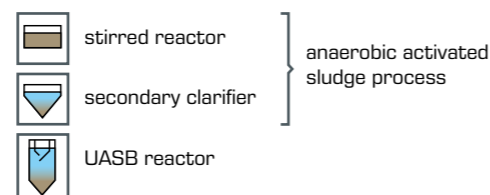

CE 702's UASB reactor during a successful trial run in our laboratory

Software

The software included with CE 702 shows the temperatures and pH values in both reactors continuously. This gives you a quick overview of the conditions in the reactors at any time. You can save the measured values for analysis. This relieves you of routine work and thus aids you when conducting the experiments.

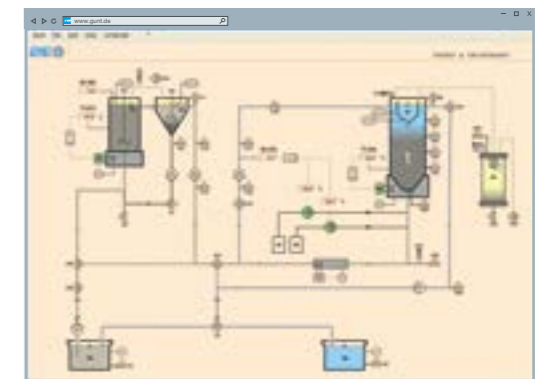

Process schematic with display of the measured values

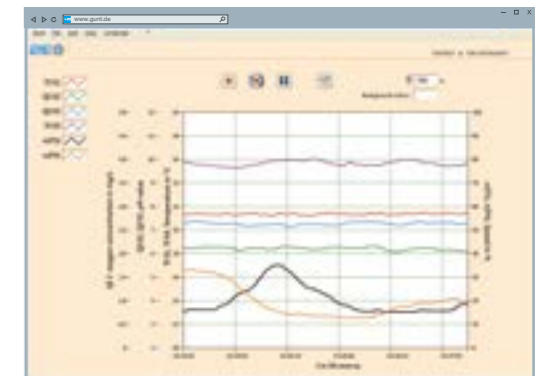

Display of the measured values as time dependency

Learning objectives

- effects of temperature and pH value on anaerobic degradation
- functional principle of a UASB reactor
- comparison of single stage and dual stage operation mode
- monitoring and optimisation of the operating conditions
- identification of the following influencing factors
 - ▶ sludge loading
 - ▶ volumetric loading
 - ▶ flow velocity in the UASB reactor

Basic knowledge

Physical/chemical water treatment

Application of physical/chemical processes

Industrial wastewater often contains dissolved inorganic substances (e.g. heavy metals) or organic materials which cannot be biodegraded. This is also true of a lot of landfill leachate and contaminated groundwater. The use of physical/chemical processes is ideal in such cases. There is a variety of different processes in this field of water treatment. The most widely used processes include:

Adsorption

Reverse osmosis

Ion exchange

Precipitation

Flocculation

Oxidation processes

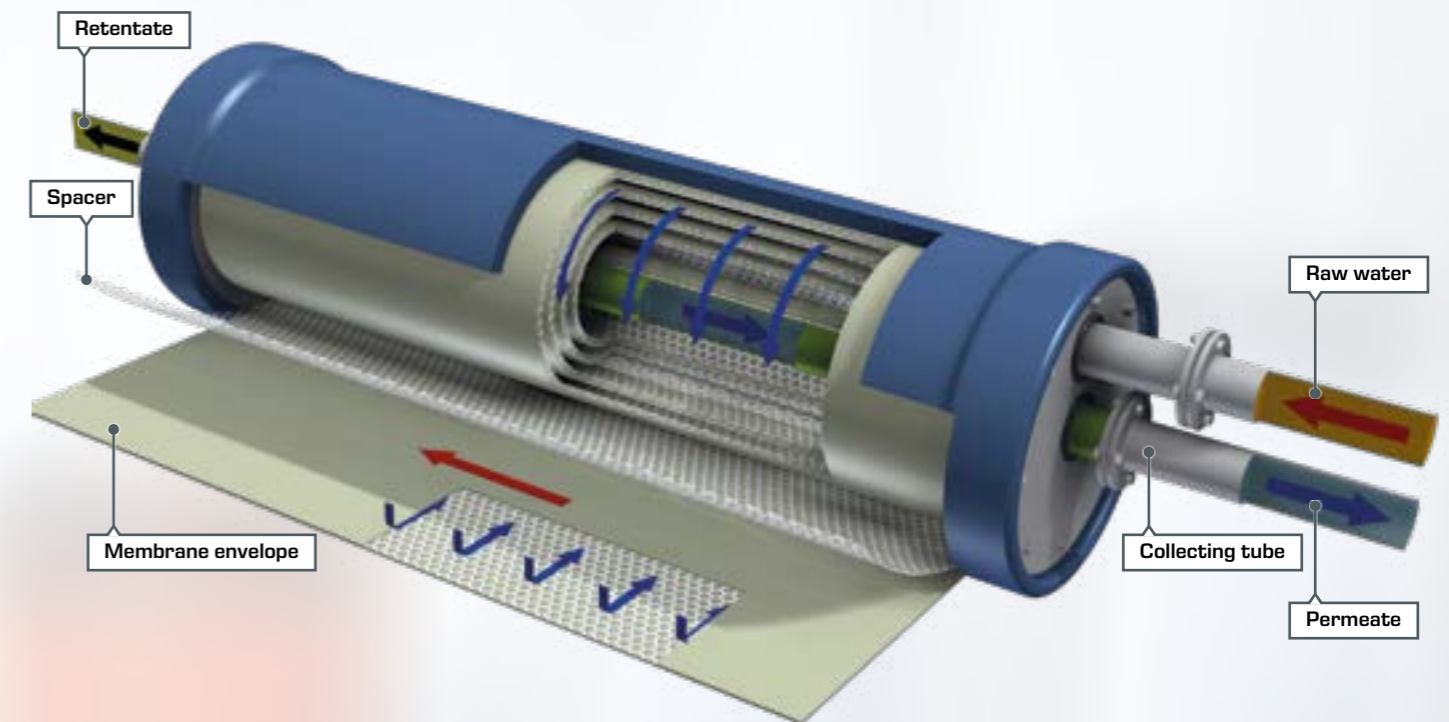

Adsorption

In adsorption, the material to be removed (adsorbate) is bonded to the surface of a solid (adsorbent). This bonding can be either physical or chemical. The adsorbent is predominantly granular activated carbon. This procedure can be used to reliably remove toxic, chlorinated hydrocarbon compounds from the water. Such substances are found in many places in landfill leachate and contaminated groundwater.

Adsorption is generally carried out with continuous-flow adsorbers. The adsorbers contain a fixed bed of granular activated carbon. After a certain period of operation, the adsorbate concentration in the outlet of an adsorber rises. This condition is referred to as breakthrough. If the adsorbate concentration in the outlet of an adsorber is plotted over time, it shows what is known as the breakthrough curve.



Continuous-flow adsorber in a water treatment plant

Reverse osmosis: membrane separation process for the strictest demands

The basic principle of reverse osmosis is quite simple. The natural tendency to bring about a concentration equilibrium between the two sides of a membrane (osmosis) must be countered. To do this, counter-pressure which is at least as high as the osmotic pressure is built up. The water then flows across the membrane in the direction of the concentration gradient, thereby sharply increasing the concentration on one side of the membrane (retentate) and decreasing it on the other side (permeate). To put it simply, reverse osmosis can be regarded as a dilution process.

Even dissolved substances such as ions can be removed from the water by reverse osmosis. This means ultrapure water, which is required in many sensitive industrial production processes, can be produced, for example in the pharmaceutical industry. Another application is the desalination of sea water.

Reverse osmosis uses what are known as spiral-wound membranes. One special feature of this design is the membrane envelope wound spirally around a central tube. The high pressure on the inlet side causes the water (permeate) to pass across the membrane and to flow spirally into the central collecting tube. The partial flow (retentate) retained by the membrane is removed via a separate tube.

Basic knowledge

Physical/chemical water treatment

Ion exchange

Ion exchange is a physico-chemical process in which a solid absorbs ions from a liquid, and in exchange emits an equivalent amount of equally charged ions to the liquid. If positive ions are exchanged (e.g. sodium Na⁺), the process is called cation exchange. In contrast, anion exchange is where negatively charged ions are exchanged (e.g. chloride Cl⁻).

Ion exchangers are used primarily for desalination and softening. Heavy metals contained in a lot of wastewater from the metal-working industry can be removed by ion exchange.

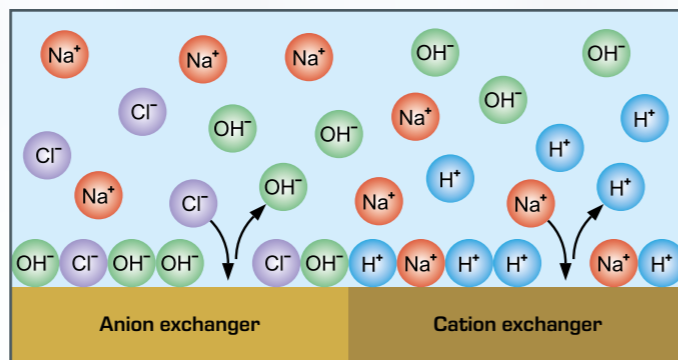

Desalination by anion exchange followed by cation exchange

Precipitation

Precipitation is a chemical process in which a dissolved substance is transformed in an insoluble form (solid) by reaction with another substance. Precipitation is suitable for removing dissolved metals, for example. In addition, precipitation is also used for phosphorus elimination in wastewater treatment plants.

In practice, precipitation is often followed by flocculation in order to increase the size of the solids which are formed. This eases the subsequent mechanical separation of the solids (for example by sedimentation).

Flocculation

To add certain chemicals the electrostatic repulsive forces between the individual solid particles have to be removed first. As a result, the particles combine to form small flocs (coagulation). To increase the size of the flocs even further, a flocculant (e.g. polymer) is added to the water. This results in flocs several millimetres in diameter, which can easily be separated subsequently by mechanical means.

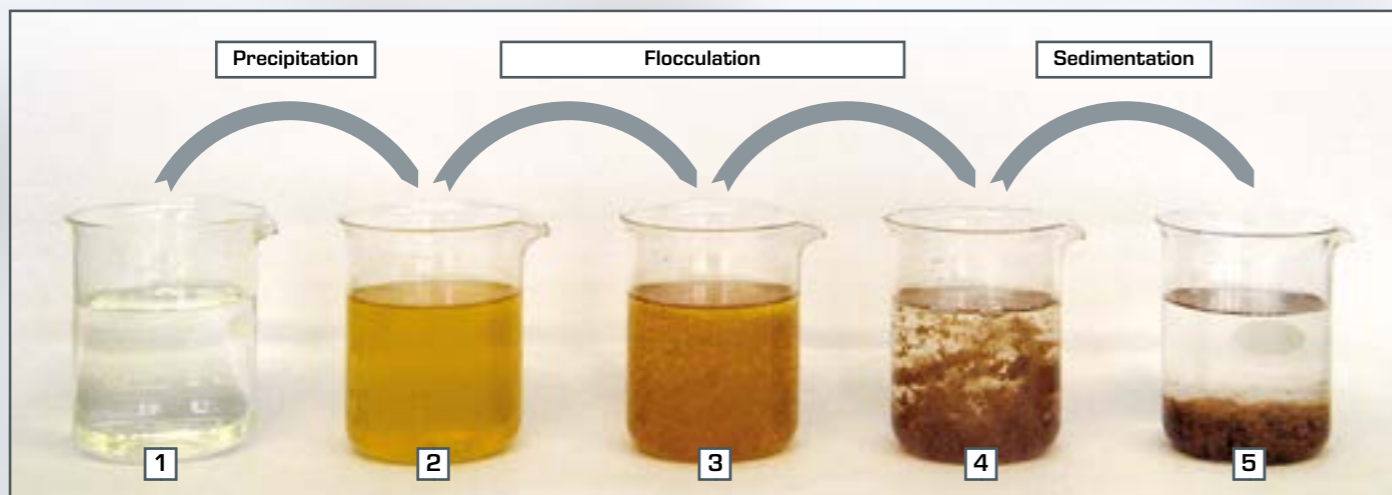

Precipitation and flocculation of dissolved iron:
By adding caustic soda, the dissolved iron (1) first precipitates as insoluble and yellow iron hydroxide (2). Adding other chemicals causes large iron hydroxide flocs (3 to 4) to form, which can then easily be separated by sedimentation (5).

Oxidation processes

Many organic contaminants are not biodegradable and therefore cannot be eliminated by biological processes. These include many chlorinated hydrocarbons. Improper handling of these materials allows them to enter the groundwater where they pose a threat to humans and the environment. An effective method of removing such materials from the water is with oxidation processes.

There is a variety of different oxidation processes in the field of water treatment. The importance of those referred to as "advanced oxidation processes" has increased in the past few

years. The main feature of these processes is the formation of highly reactive OH radicals. These radicals are some of the strongest oxidants and thus are able to oxidise almost any substance.

OH radicals can be produced with UV light, for example by irradiation of hydrogen peroxide (H₂O₂). UV-C radiation with a wavelength of 254 nm is mainly used for this purpose.

Producing an OH radical with UV light and hydrogen peroxide (H₂O₂)

- oxygen
- hydrogen
- free electron

CE 583 Adsorption

Adsorptive water treatment in continuous operation

Adsorption on activated carbon is an effective and often practised alternative to the removal of non-biodegradable organic substances, such as chlorinated hydrocarbons. Our CE 583 device allows you to demonstrate the fundamentals of this process in continuous operation and therefore under very practical conditions.

The main components of this device are two series-connected adsorbers which are filled with granulated active carbon. The first adsorber is equipped with sampling valves so that you can determine concentration profiles. Concentration profiles are essential for understanding adsorption.

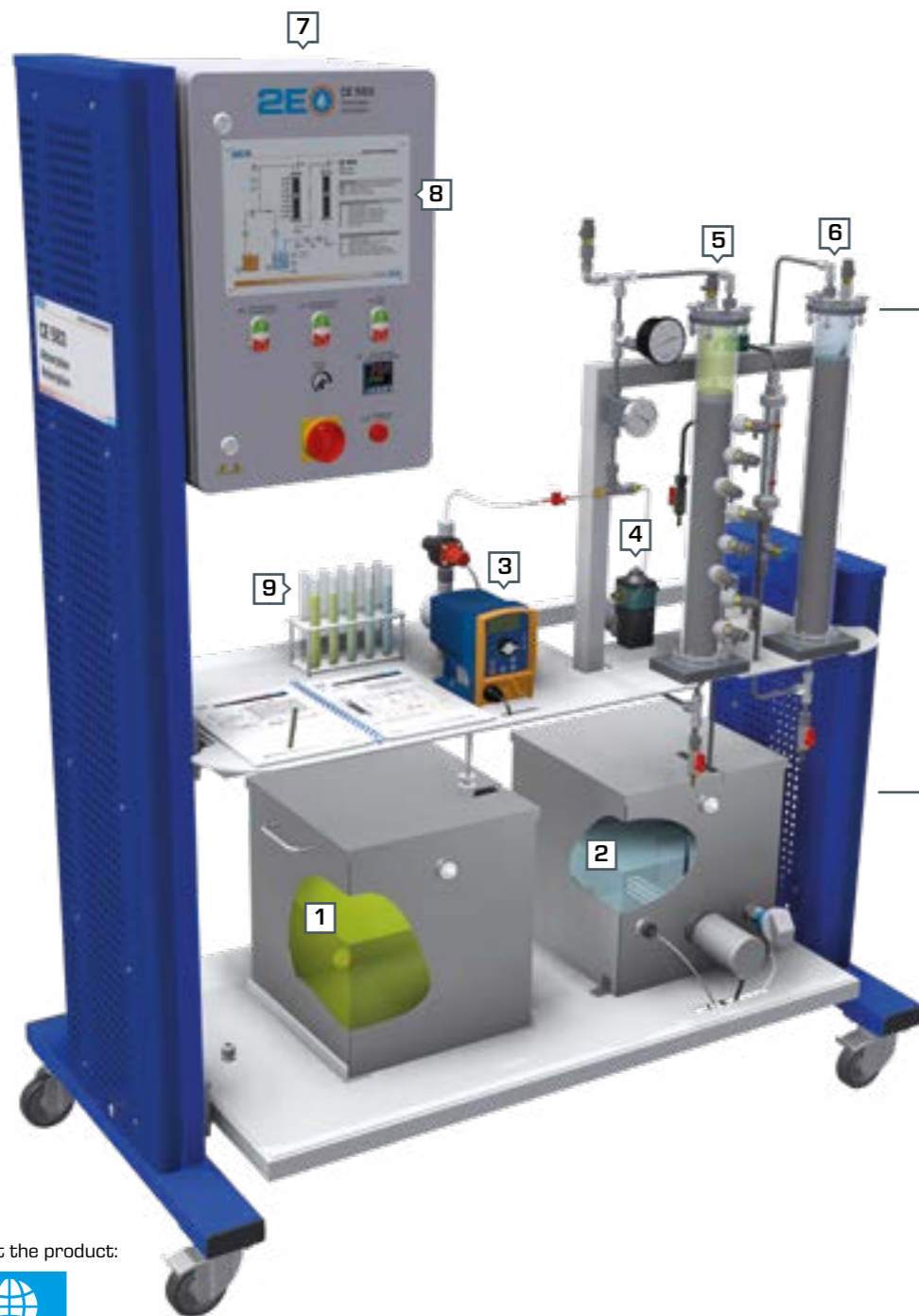

- 1 adsorbate concentrate
- 2 treated water
- 3 metering pump
- 4 circulation pump
- 5 first adsorber
- 6 second adsorber
- 7 switch cabinet
- 8 process schematic
- 9 test tubes for sampling

i Adsorbate

Adsorbate refers to the substance dissolved in the water which is to be eliminated by adsorption

Principle of operation

Treated water is circulated through both adsorbers. A metering pump injects concentrated adsorbate solution into the inlet area of the first adsorber in the circuit. The metering pump allows very precise adjustment of the flow rate. This allows you to adjust the desired feed concentration of the adsorbate very precisely. The second adsorber ensures that the circulated water doesn't contain any more adsorbate even at full breakthrough of the first adsorber. This ensures a constant adsorbate concentration in the inlet of the first adsorber, even in long-term experiments.

Temperature control

The device is equipped with a temperature control system. This allows you to study how water temperature influences the adsorption process.

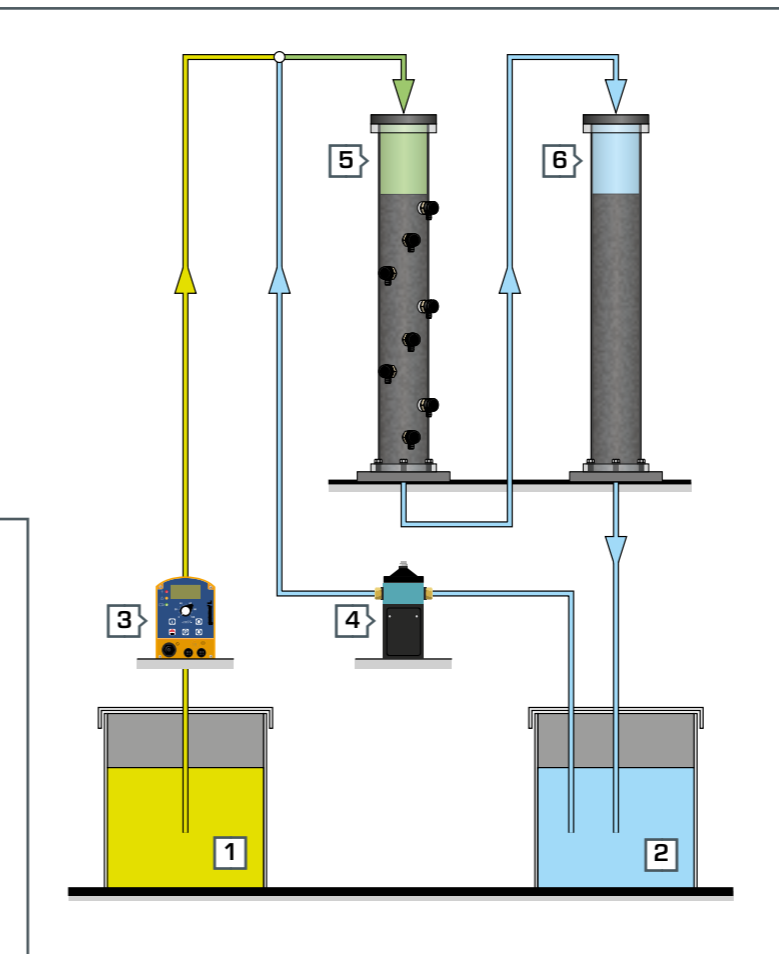

i Our recommendation

You can deliver a particularly impressive demonstration of adsorption when you use a water-soluble and adsorbable dye as the adsorbate. Such substances include methylene blue or fluoresceine.

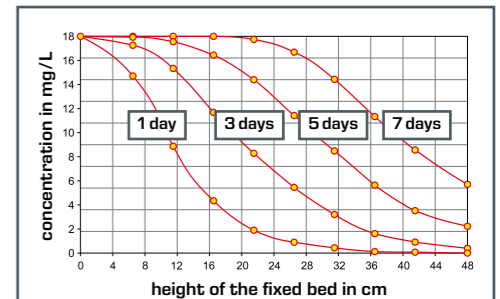

Excerpt from the CE 583 manual:
concentration profiles at various times for methylene blue

Learning objectives

- recording of concentration profiles
- recording of breakthrough curves
- relationship between concentration profiles and breakthrough curves
- determining the mass transfer zone
- an adsorber's efficiency and mass balance
- predicting breakthrough curves
- scale-up of the results to industrial scale
- factors influencing the adsorption
 - ▶ contact time
 - ▶ temperature
 - ▶ mode of operation

About the product:



CE 530 Reverse osmosis

This device has been developed in collaboration with the Institute of Thermal Separation Processes, Hamburg University of Technology.

The main component of CE 530 is the spiral-wound membrane. The construction, maintenance and operation of a spiral-wound membrane are the focal points of the didactic concept, as is the determination of specific parameters (e.g. retention capac-

ity). The device is designed for water desalination. In order to monitor the success of desalination, conductivity sensors are installed at all relevant points in the device. You can adjust the pressure and flow rate.

The instructional material sets out the fundamentals in detail and provides a step-by-step guide through the experiments.



In cooperation with
TUHH
Technische Universität Hamburg-Harburg

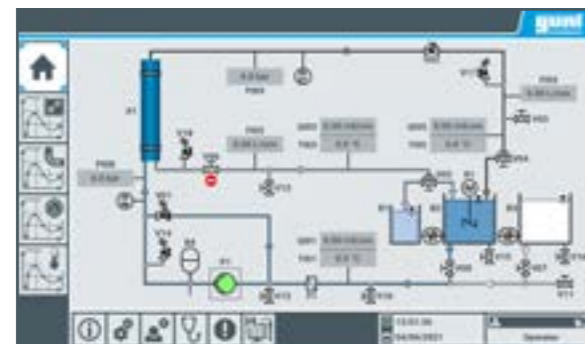

Touch screen: process schematic

About the product:



Learning objectives

- functioning of a spiral-wound membrane module
- assembly, cleaning and conservation of membrane modules
- fundamental principle of reverse osmosis
 - ▶ Van't Hoff's law
- permeate flow rate and retention dependent on
 - ▶ pressure
 - ▶ salt concentration in raw water
 - ▶ yield
- determination of diffusion coefficients

CE 300 Ion exchange

Ion exchangers are used primarily for the desalination and softening of water. Our CE 300 experimental unit allows you to demonstrate all the key aspects of ion exchange to your students.

The device has one anion exchanger and one cation exchanger. The two ion exchangers can be perfused either separately in sequence or simultaneously by simply adjusting the valves. A hand-held instrument for measuring conductivity is included for analysis of the experiments. You can regenerate the ion exchangers with acid or alkaline solution. Due to its small size, this device does not require a large laboratory and can easily be set up on tables.

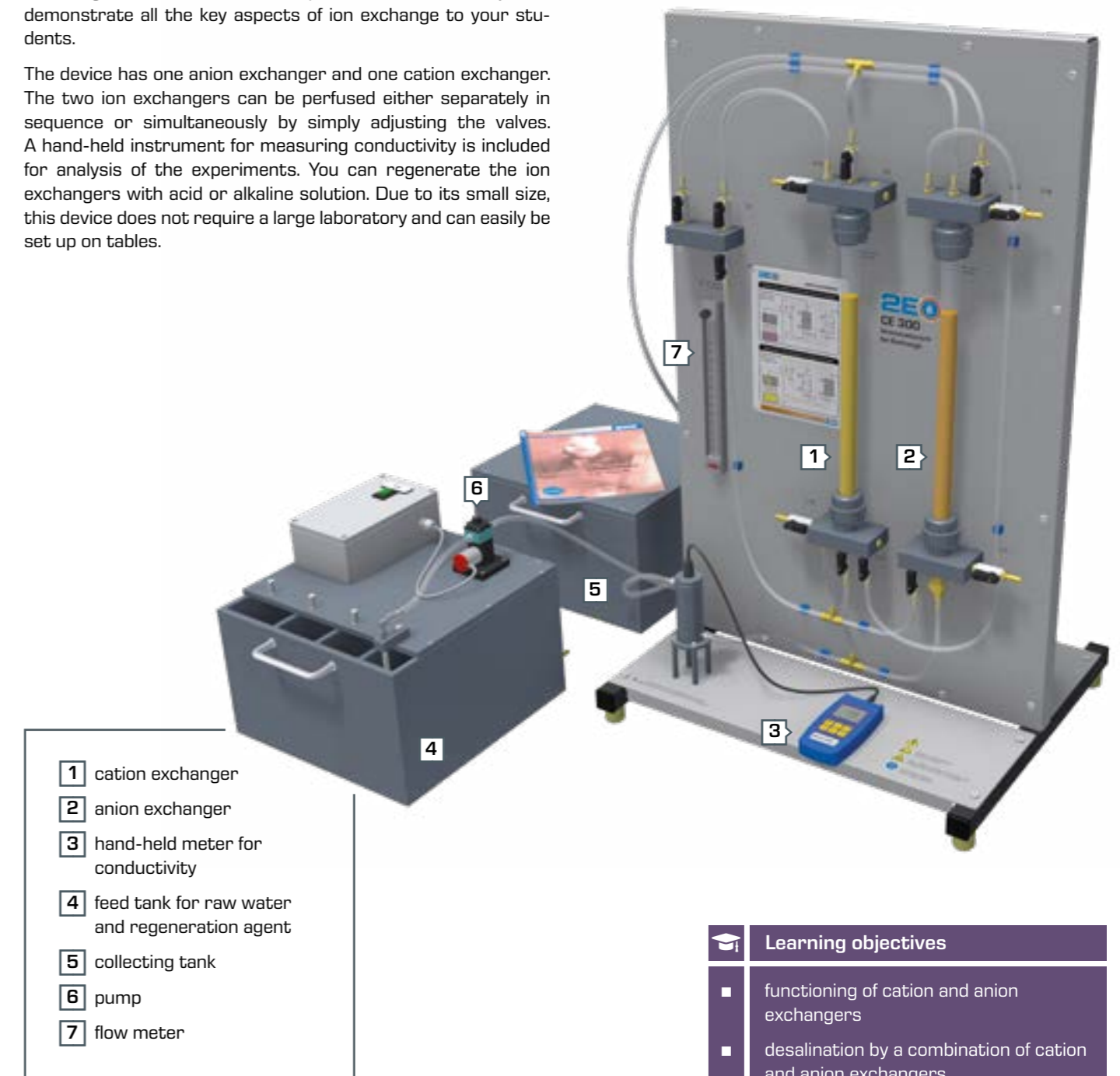

- 1 cation exchanger
- 2 anion exchanger
- 3 hand-held meter for conductivity
- 4 feed tank for raw water and regeneration agent
- 5 collecting tank
- 6 pump
- 7 flow meter

About the product:



Learning objectives

- functioning of cation and anion exchangers
- desalination by a combination of cation and anion exchangers
- determining the exchanging capacity and regeneration
- checking the theoretically calculated regeneration time

CE 586 Precipitation and flocculation

This device can be used to demonstrate precipitation and flocculation in continuous operation and under very realistic conditions. This process is divided into three stages: precipitation, flocculation and sedimentation. All the necessary components are clearly arranged on the trainer. A separate supply unit with a large storage tank is available to produce and pump the raw water.

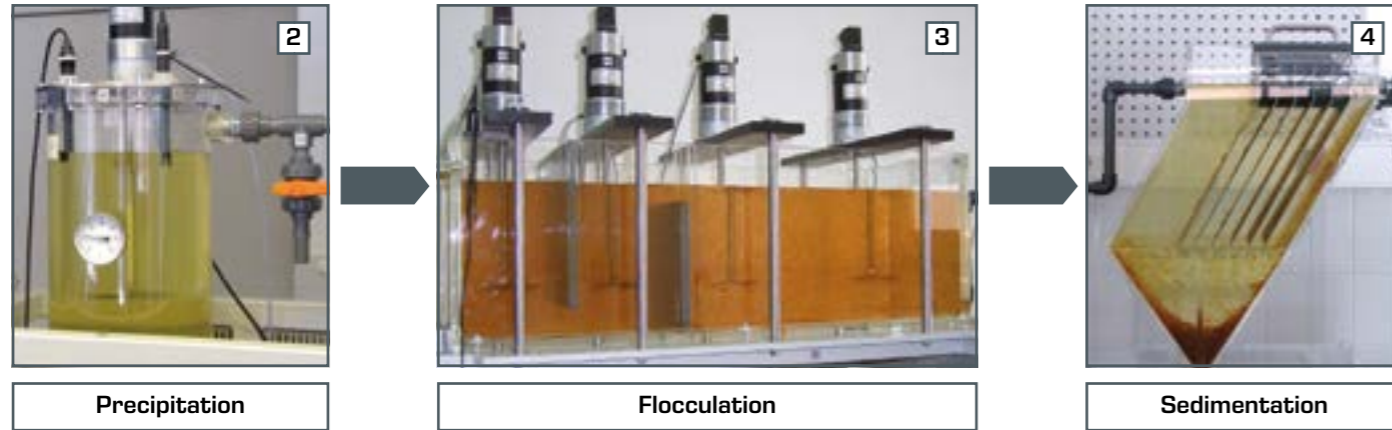

- 1 storage tank for raw water
- 2 precipitation tank
- 3 flocculation tank
- 4 lamella separator
- 5 tank for treated water
- 6 metering pump for additives
- 7 switch cabinet with large process schematic

i This device is of course accompanied by comprehensive instructional material.



- Learning objectives**
- effect of the pH value on precipitation
 - creation of a stable operating state
 - determining the required dosages of agents
 - functional principle of a lamella separator

CE 584 Advanced oxidation – H₂O₂ and UV

Falling film reactor in batch mode

Advanced oxidation processes are state-of-the-art in water treatment. This device enables you to investigate the oxidation of non-biodegradable organic substances using hydrogen peroxide (H₂O₂) and UV radiation. The educational focus is on the experimental application of reaction kinetics relationships.

The main component of the device is a falling film reactor, which is operated discontinuously. The raw water mixed with hydrogen peroxide is pumped out of a tank into a channel at the upper end of the reactor. The water flows along the inner wall of the reactor, over an overflow edge, flows down as a thin film and finally ends up back in the tank.

At the centre of the reactor there is a UV lamp. Irradiation with UV light (254 nm) causes the hydrogen peroxide to be split into the desired OH radicals.

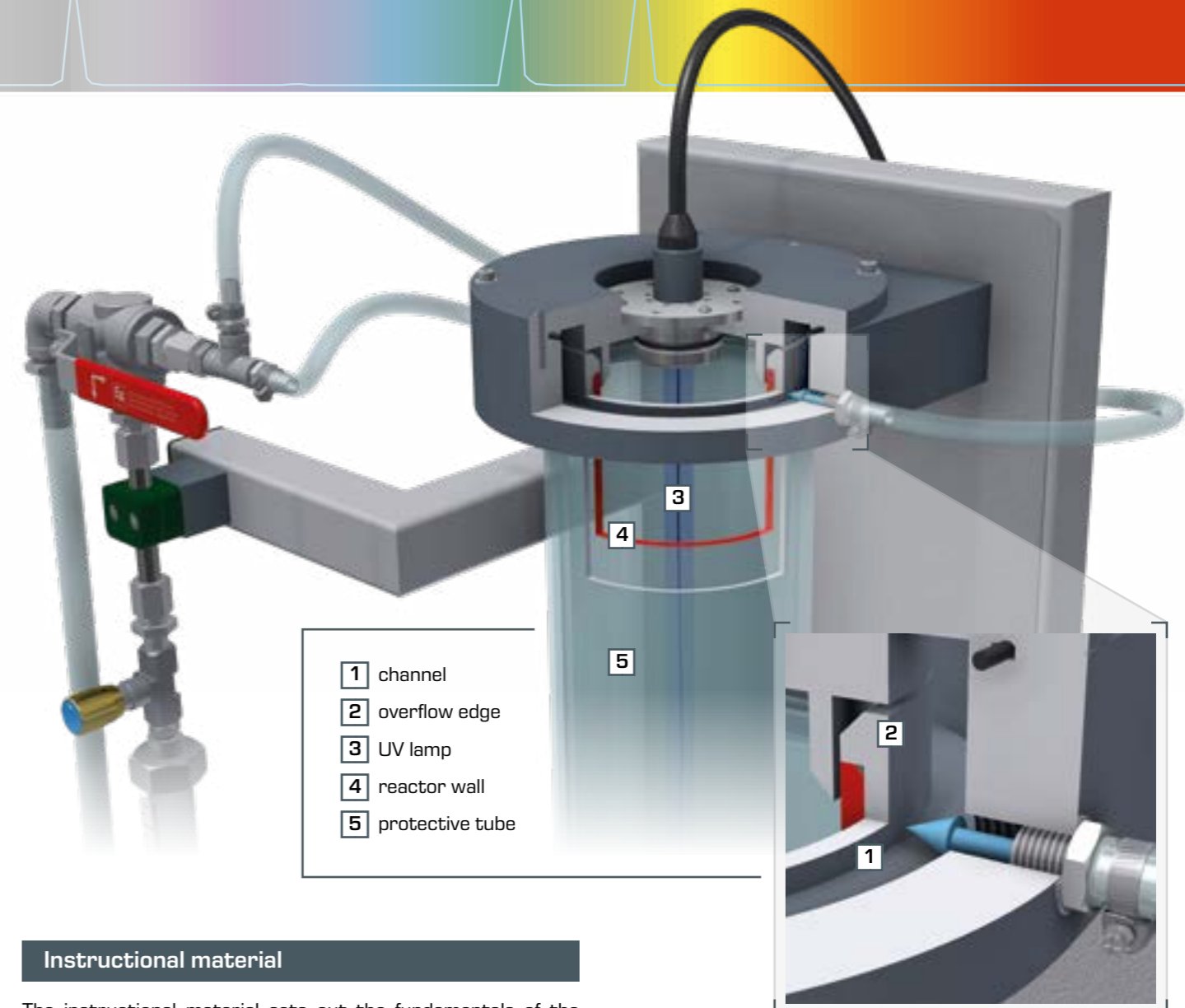

Instructional material

The instructional material sets out the fundamentals of the process and the reaction kinetics relationships in detail. In addition, an experiment is described in detail and evaluated as an example.

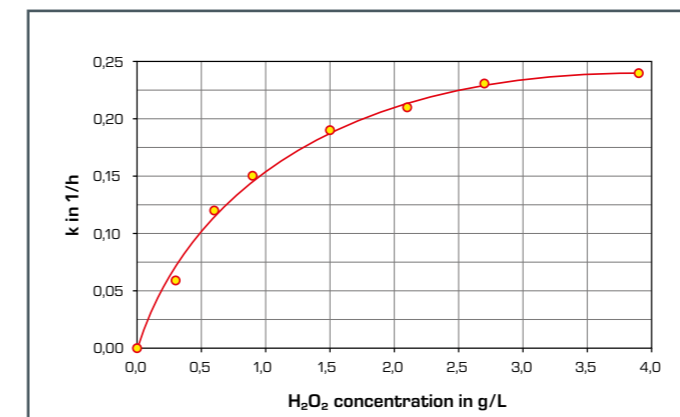

Excerpt from the CE 584 manual: rate constant k as a function of the amount of H₂O₂ used. Triethylene glycol dimethyl ether was used as the organic contaminant.

Learning objectives

- plotting concentration time curves
- investigation of reaction kinetics
 - ▶ order of reactions
 - ▶ reaction rate
- effect of amount of H₂O₂ on the reaction progress

About the product:



Basic knowledge

Multistage water treatment

Multistage water treatment

Water to be treated usually contains several substances with different properties. Consequently, a single basic process is not sufficient to remove these substances. Water treatment plants are therefore generally built in several stages.

From the point of view of environmental protection, plants for treating contaminated groundwater are a classic application example of complex, multistage water treatment.

Solids contained in the untreated raw water can cause damage or blockages in plant components (e.g. pipelines and pumps). A mechanical treatment is therefore first applied to remove the solids. If the solids only emerge during the course of the water treatment, such as precipitation and flocculation, mechanical treatment steps are also used in the later stages of water treatment.

Groundwater treatment

Contaminated groundwater is usually treated with the "pump and treat" method. Here, the groundwater is pumped downstream of the contamination zone and purified by conventional processes of water treatment. The purified groundwater is then infiltrated back into the ground upstream of the contamination zone. This creates a circuit into which the groundwater treatment plant is integrated.

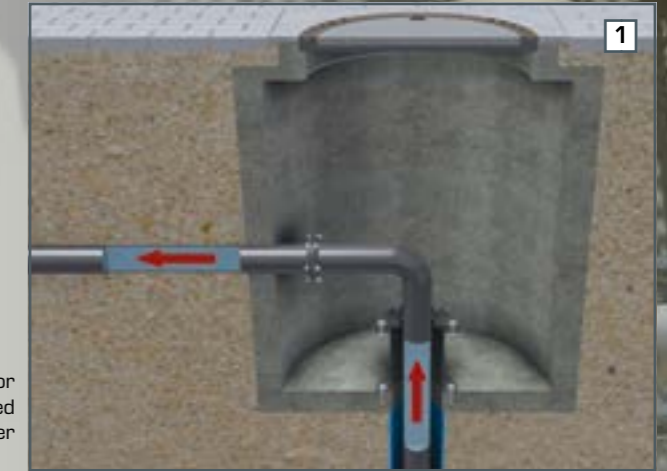

Well for contaminated groundwater



Multistage groundwater treatment plant

- | | |
|---------------------------------------|---|
| 1 wells | 9 collection tank for sludge |
| 2 inlet of wells | 10 adsorption on activated carbon |
| 3 precipitation (e.g. dissolved iron) | 11 adsorber for exhaust air from stripping |
| 4 flocculation | 12 collection tank for purified groundwater |
| 5 lamella separator (sedimentation) | 13 outlet to infiltration wells |
| 6 buffer tank | 14 infiltration wells |
| 7 sand filter | |
| 8 stripping | |

CE 581 Water treatment plant 1

This device allows you to clearly demonstrate and investigate the features of multistage water treatment. There are six consecutive process steps available.

Depth filtration	1 gravel filter
	2 sand filter
Adsorption	3 aluminium oxide
	4 activated carbon
Ion exchange	5 mixed bed exchanger
	6 cation exchanger



About the product:



Software and PLC

The device is operated with a PLC (programmable logic controller). The software displays all the measured process variables continuously. Of course, the software also allows you to save the measured values for analysis.

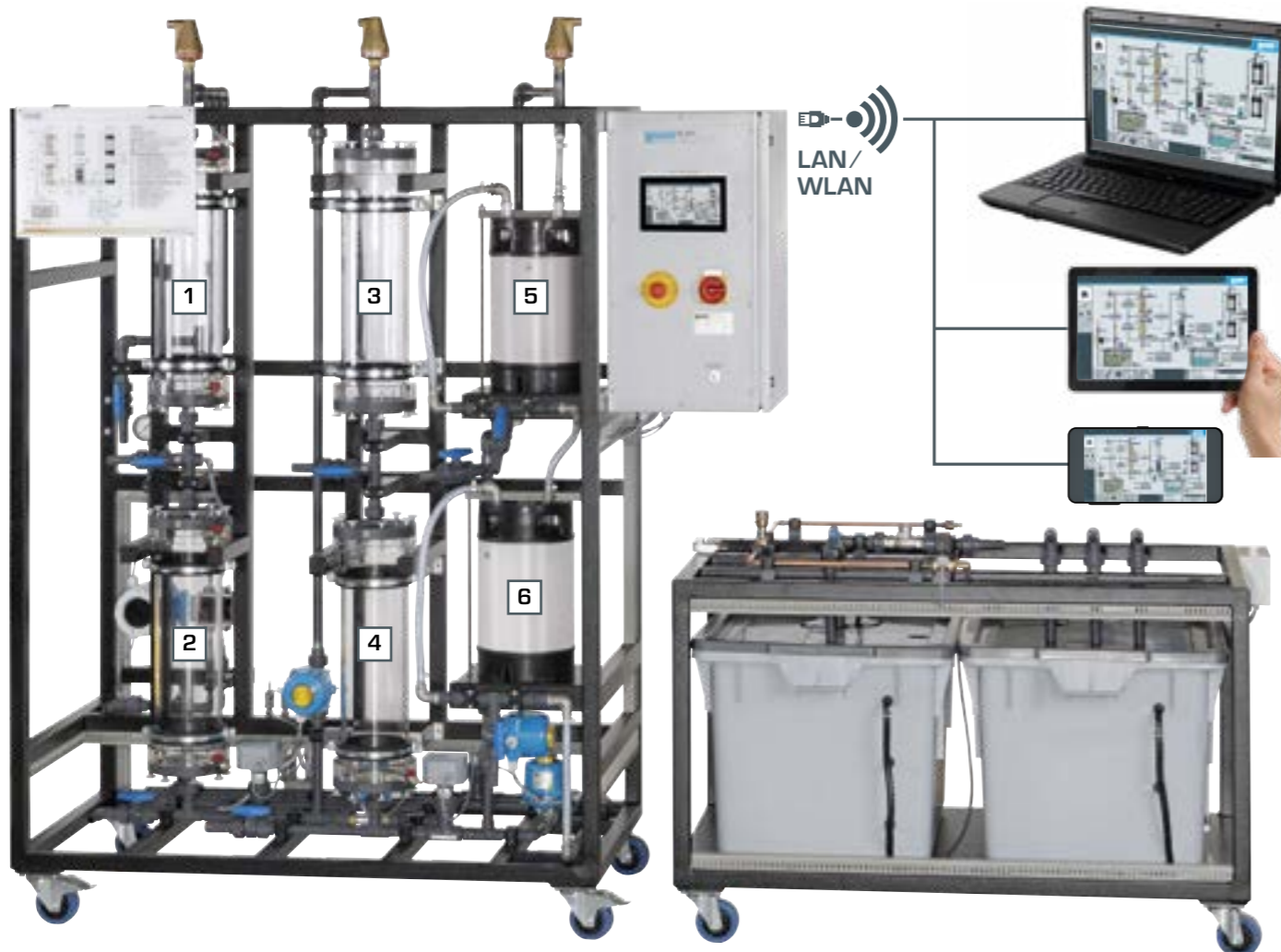

Operating variants

The individual process steps can be enabled or disabled separately. By adjusting electrically driven ball valves, you can choose between the following 3 operating variants:

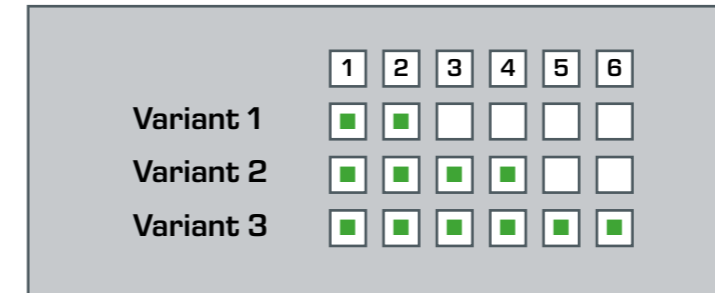

Learning objectives

- learning the fundamental principle of the unit operations depth filtration, adsorption and ion exchange
- observation and determination of the pressure loss in depth filtration
- plotting of breakthrough curves (adsorption)
- comparison of various adsorption materials
- familiarisation with the fundamental principle of ion exchange

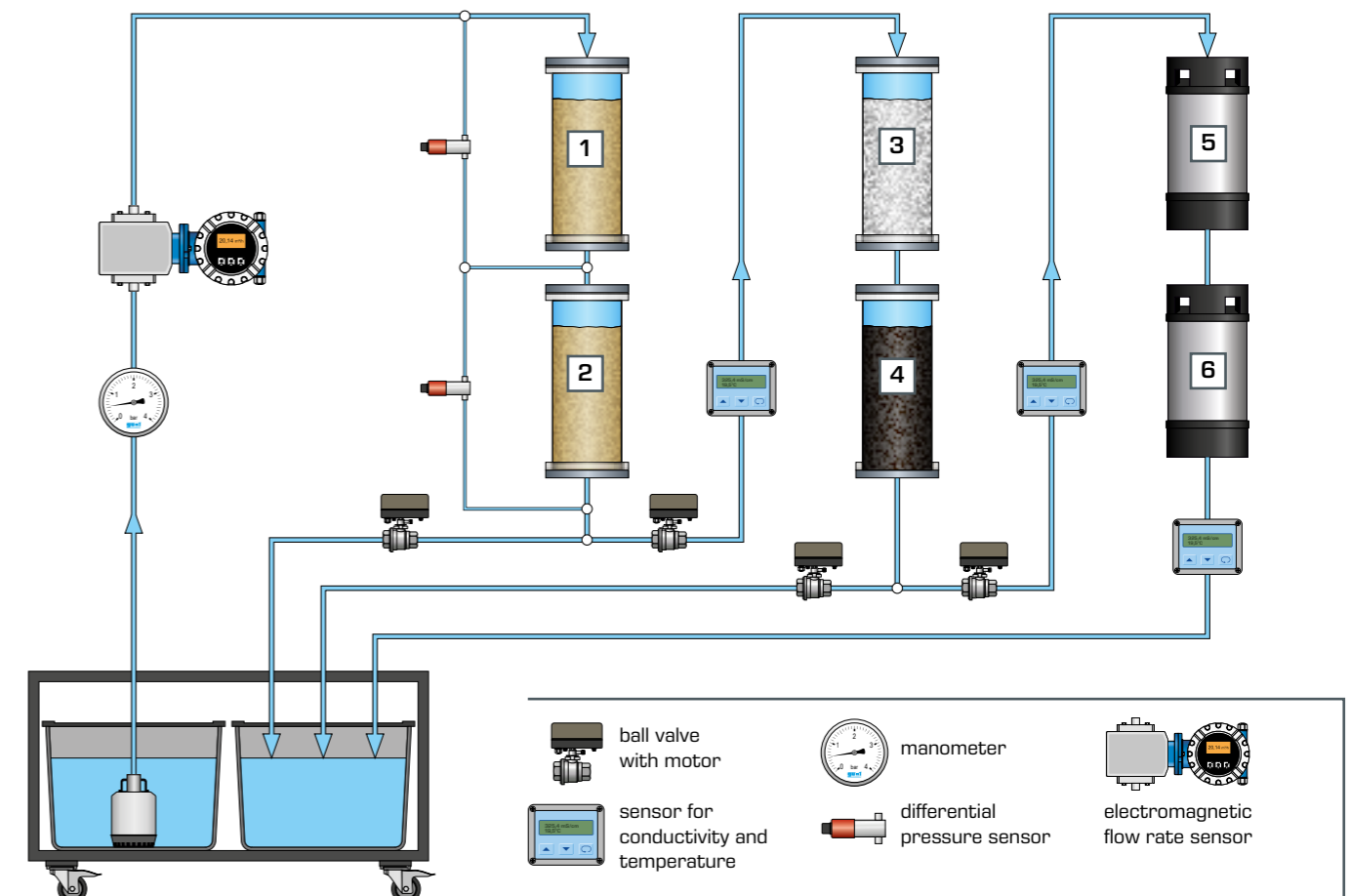

CE 582 Water treatment plant 2

Water treatment with sand filter and ion exchanger

This device allows you to clearly demonstrate and investigate the features of multistage water treatment. A sand filter and two ion exchangers are available for this purpose.

With the sand filter the didactic focus is the investigation of the pressure ratios in the filter bed. In order to measure the pressures, the sand filter is fitted with differential pressure measurement and a number of individual measuring points along the filter bed. These measurement points can be connected to a manometer panel, enabling you to measure the

pressure conditions in the filter bed very accurately. The manometer panel has 20 separate tube manometers. By using a transparent filter tube, you can also observe the increased loading of the filter bed visually. The sand filter can be rinsed back if necessary.

Ion exchange takes place after filtration. A cation exchanger and an anion exchanger are available for this purpose. The device also allows for regeneration of the ion exchanger.



- 1 manometer panel
- 2 sand filter
- 3 ion exchanger
- 4 storage tank for regeneration agent
- 5 tank for raw water and treated water
- 6 backwash pump

About the product:

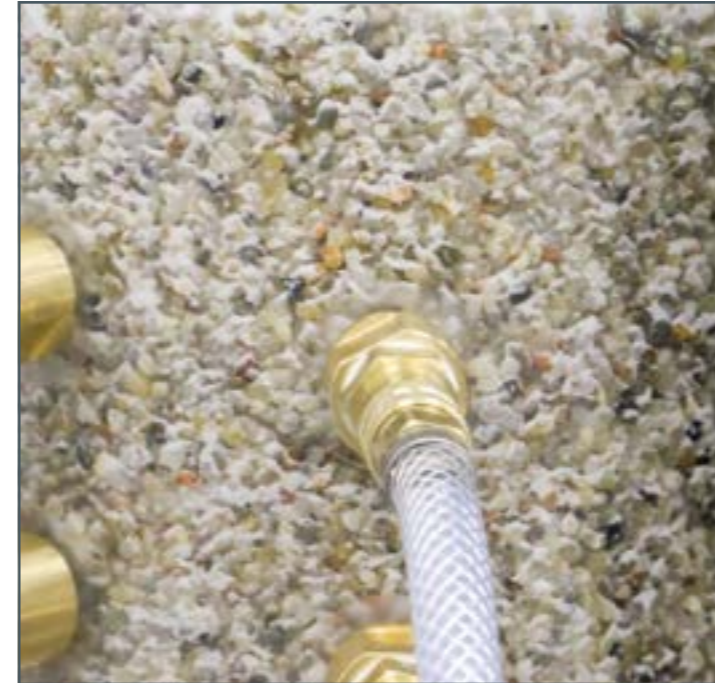

By using a transparent filter tube, you can also observe the increased loading of the filter bed visually as well as using the rise in pressure loss.



Standard at GUNT: use of professional instrumentation

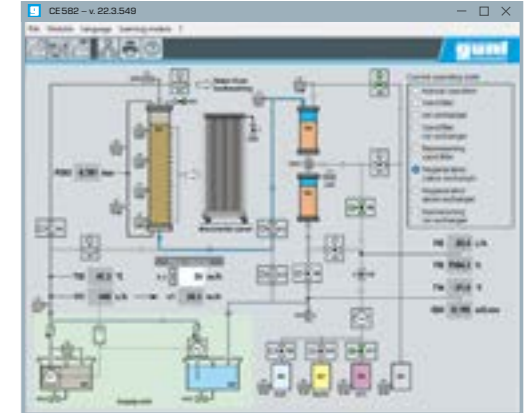

Software

The device is equipped with extensive instrumentation. The device is operated with modern and clearly-arranged software. The software displays all measured process variables continuously. Of course, the software also allows you to save the measured values for analysis.

Learning objectives

- observation and determination of pressure losses in a sand filter
- plotting of Micheau diagrams
- backwash of sand filters
- modes of operation of cation and anion exchangers
- regeneration of ion exchangers

CE 585 Water purification process



CE 585 is one of the Industrial Application Projects from the GUNT-TVET programme. Students learn extensive operating functions and maintenance work on this industry standard, multi-stage water purification plant.

The plant consists of the following process stages: aeration (oxidation), filtration (mechanical filter with BIRM®, candle filter, activated carbon filter), softening (ion exchange), disinfection using UV light. The aim of the process is to remove certain substances from the raw water, such as dissolved iron.



Screenshot from the PLC



About the product:



H₂SKILLS
Green hydrogen expertise



The GUNT range of units for the development of H₂SKILLS enables future specialists in the hydrogen industry to receive practical training. For teachers, the hydrogen devices are didactically incorporated into the classroom to ensure the effective transfer of knowledge.

Raw water is purified in the CE 585 plant. Purified water is the basis for the production of hydrogen using electrolysis.

The GUNT Skills Media Center



Digital data packages are available on GUNT's own didactic platform:

- functional videos
- exercises on maintenance and function
- manual

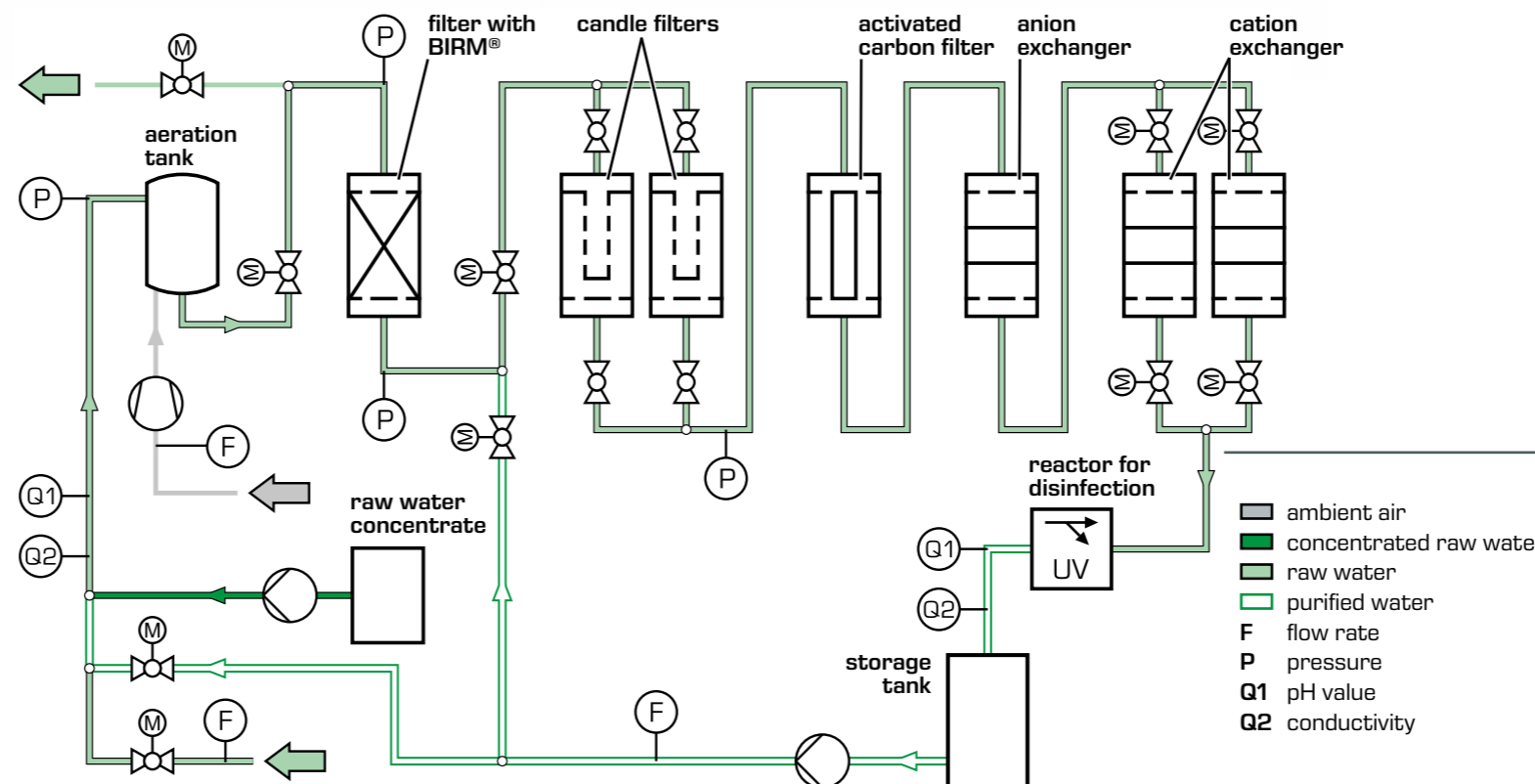
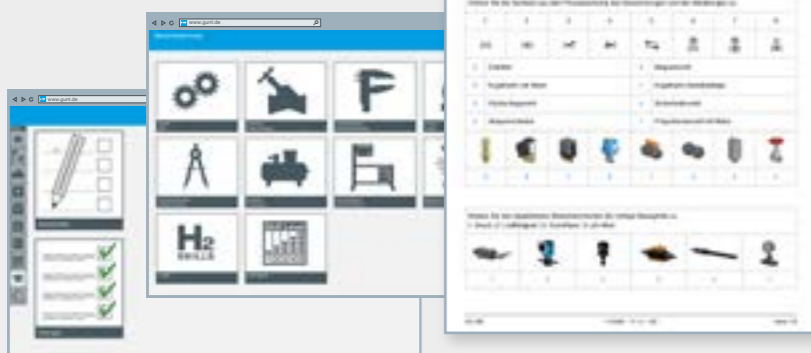
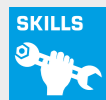

Learning objectives

- operation of an industrial-scale water treatment plant
- setting and monitoring important process variables
- detecting malfunctions
- carrying out and documenting maintenance work
- installation and removal of system components
- monitoring, determination and documentation of water analysis parameters



Air

Introduction

Subject areas

Air

060

Basic knowledge

Air pollution control

062

Mechanical processes

CE 235

Gas cyclone

064

Thermal processes

CE 400

Gas absorption

066

CE 540

Adsorptive air drying

068

Subject areas
Air

Subject areas

Products

The didactic focus of the air subject area is the various methods for treating gaseous media (air pollution control). Most contaminants can be removed from an exhaust airflow by mechanical or thermal processes.

Mechanical processes

Mechanical processes are used to remove solid particles from an exhaust airflow (dust extraction). Gas cyclones are a very effective and therefore widely used method for dust extraction. Our CE 235 device allows you to clearly demonstrate this process.

Thermal processes

The use of thermal processes is suitable if the exhaust air to be cleaned contains gaseous contaminants. Most often these are absorption and adsorption. We offer you trainers for both of these processes, in order to investigate the theoretical fundamentals of both processes in a practical way in the laboratory.



Process engineering

» Process
engineering

The processes used in air pollution control have their origins in classical process engineering. Other devices of interest from this field can be found in our product range "Process engineering".

Mechanical processes

CE 235
Gas cyclone

Thermal processes

CE 400
Gas absorption
CE 540
Adsorptive air drying

Basic knowledge

Air pollution control

Air – the basis of life for all living beings

The composition of the atmosphere has changed considerably since the beginning of industrialisation due to the interference of mankind. The destruction of the ozone layer and global warming are becoming ever more visible and are undoubtedly attributable to the excessive discharge of contaminants into the atmosphere. This poses a serious threat to all life on earth. The goal therefore must be to reduce the discharge of contaminants into the atmosphere as far as possible. Primarily, it is desirable to reduce the amount of contaminants that occur. Where this is not possible, the exhaust air must be cleaned by suitable processes.

Worldwide contaminant transport

The effects of a contaminant entering the atmosphere are not restricted locally. Instead, contaminants are transported by wind over many thousands of kilometres above the earth. This explains why nowadays contaminants are detected in the atmosphere even in the most remote regions far away from civilisation.

The most well-known example is the "Arctic Haze", the yellowish brown haze appearing over the Arctic in winter and spring. Aerosols from the industrial regions in Eastern Europe and Asia are regarded as the main cause for this phenomenon. The aerosols are mainly composed of sulphur and carbon.

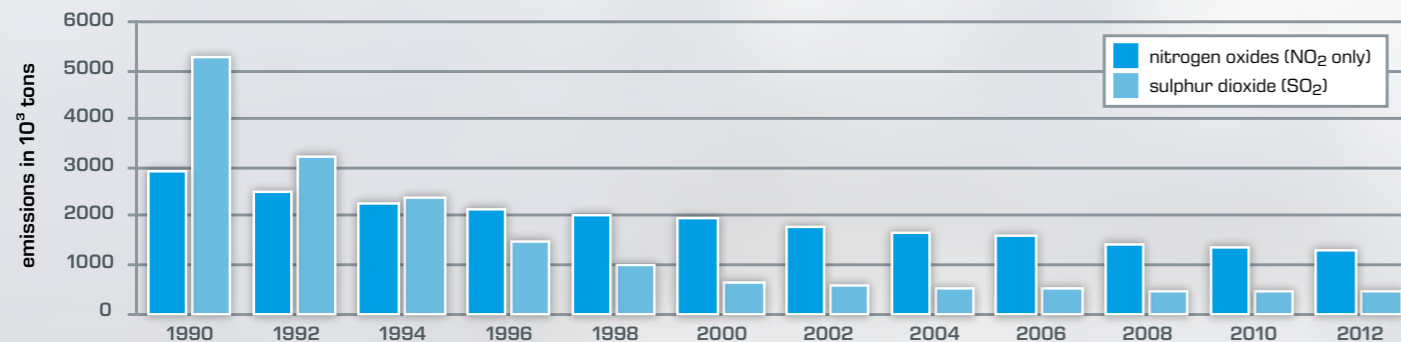
Emissions of sulphur dioxide (SO₂) and nitrogen oxides (NO₂ only) in Germany

Source: Federal Environment Agency, national trend tables for German reporting of atmospheric emissions (published 2014)

Processes of air pollution control

A number of processes are available for air pollution control, of which most can be categorised into one of the following groups:

- mechanical processes
- biological processes
- thermal processes

Biological processes

In biological processes, gaseous components are degraded microbiologically. Since the components must be biodegradable and may only be present in low concentrations, the field of application of biological processes is very limited. Biological processes are mainly used for odour problems such as occur in rendering plants, for example.

Mechanical processes

The aim of mechanical processes is separation of particles from an exhaust gas flow (dust extraction). The separation of particulate matter in particular is of great importance.

Centrifugal force separator (cyclone)

The gas flow to be cleaned is forced into a circular path in a cyclone. The resulting centrifugal force acting on the particulate matter amounts to a multiple of the force of gravity. This explains why this process can also separate very small particles in comparison to simple gravity separation (sedimentation). The separation limit of cyclones is of the order of 10 µm.

Electrostatic separators

In an electrostatic separator, the particles are first electrically charged. The charged particles then deposit onto an oppositely charged electrode. A layer of dust, which must be removed mechanically every so often, forms on the electrode. An electrostatic separator can be used to separate out particles smaller than 1 µm.

Thermal processes

Thermal processes are used to remove gaseous contaminants. Two of the most widespread processes are absorption and adsorption. Both processes are versatile and suitable for removing nitrogen oxides, sulphur dioxide, hydrogen sulphide and carbon dioxide, for example. Essentially, for both processes it can be said that the exhaust gas should largely be free of dust, which means mechanical cleaning needs to take place initially.

Absorption

At least three components are involved in absorption: the contaminant to be separated, the carrier gas and a solvent. The solvent absorbs the gaseous substance; this can be implemented physically or chemically. In order to ensure that the solvent only absorbs the contaminant and not the carrier gas, the solvent must be adapted to the respective application.

Adsorption

In adsorption, the contaminant to be removed is bonded to the surface of a solid (adsorbent). As with absorption, this can use either physical or chemical means. Activated carbon is a very frequently-used adsorbent. Adsorption is favoured by low temperatures. The exhaust gas to be cleaned should therefore not be warmer than 30°C.

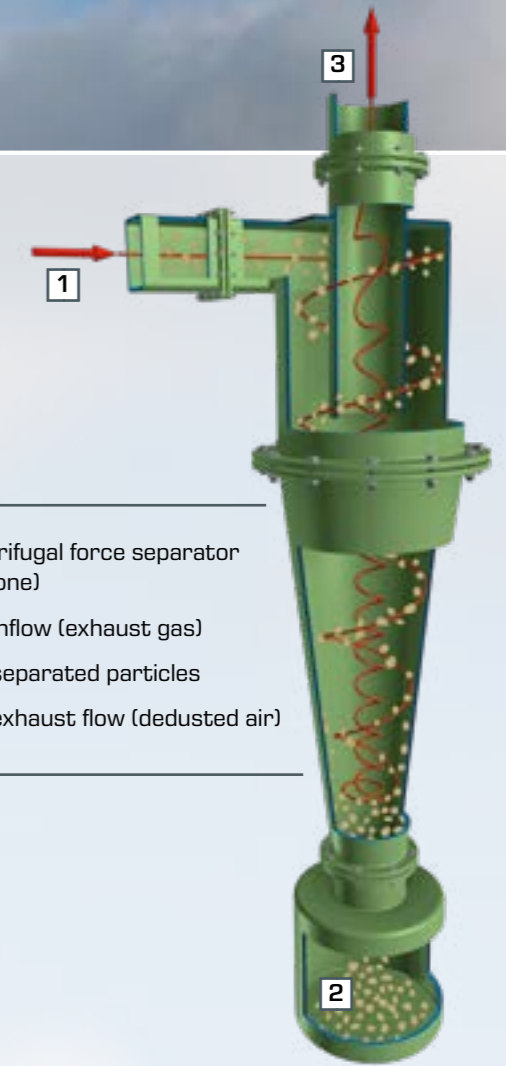

Centrifugal force separator (cyclone)

- 1 inflow (exhaust gas)
- 2 separated particles
- 3 exhaust flow (dedusted air)

CE 235 Gas cyclone

Gas cyclones are used for separating solid particles from an airflow. This device can be used to teach the fundamentals of this important process in the field of air pollution control.

The CE 235 cyclone is made of transparent material. This allows you to observe the spiral motion of the solid particles down to the bottom of the cyclone.

You can of course adjust all characteristic variables relevant to the process. These include the volumetric flow rate and the solids content of the raw gas. In order to adjust the solids content, the device is equipped with a disperser. The temperature of the raw gas, the differential pressure across the cyclone and the feed rate of the feed material are measured and displayed digitally.

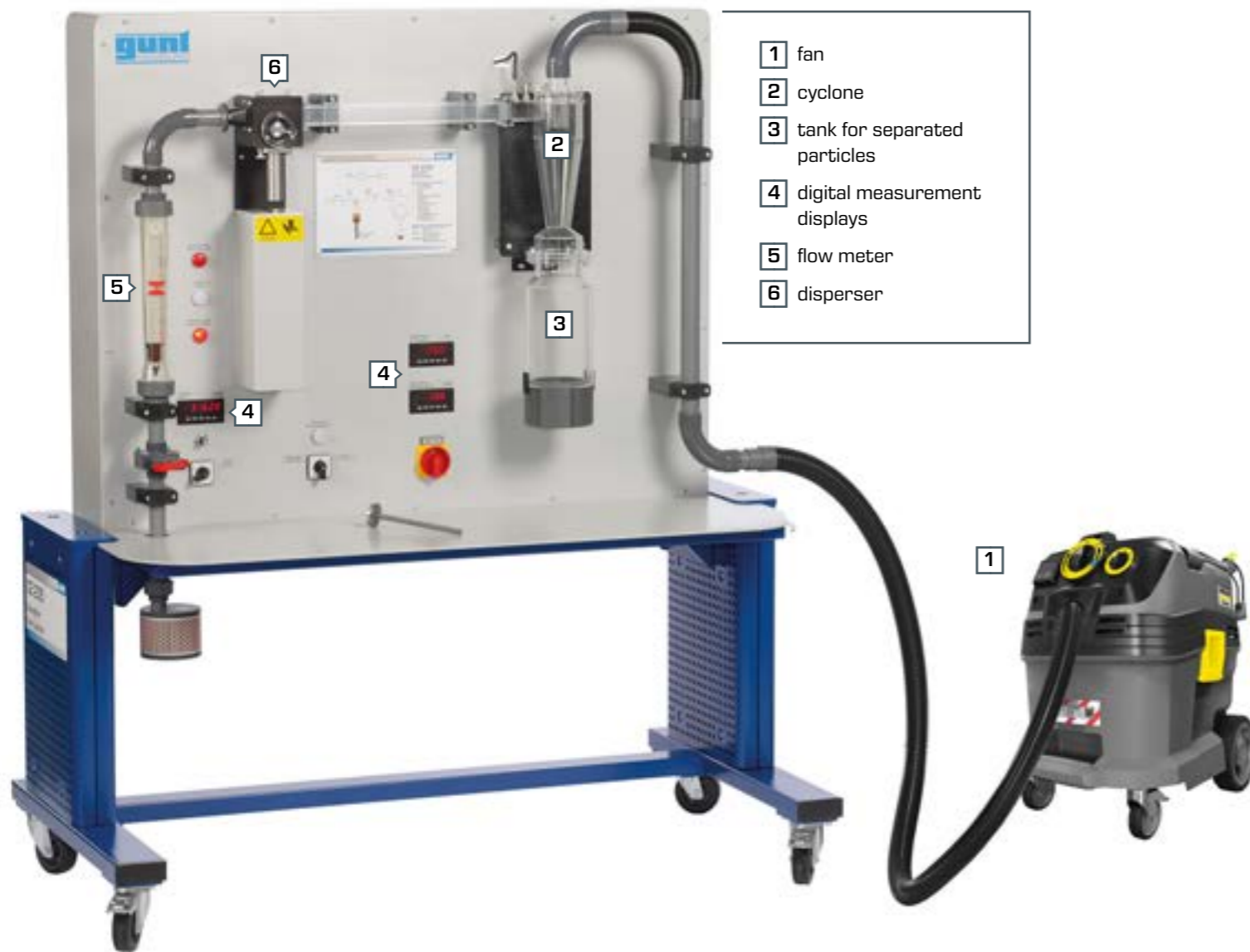

- 1 fan
- 2 cyclone
- 3 tank for separated particles
- 4 digital measurement displays
- 5 flow meter
- 6 disperser



Separation of respirable crystalline silica in the gas cyclone during a test run in our laboratory. You can see the spiral motion of the particles which is characteristic of cyclones.

Learning objectives

- influence of solid content and volumetric airflow rate on
 - ▶ pressure loss at the cyclone
 - ▶ degree of separation
 - ▶ separation function and separation size
- comparison of pressure loss and degree of separation with theoretically calculated values

TUHH

Technische Universität Hamburg-Harburg

This device has been developed by our experienced engineers in collaboration with the Institute of Solids Process Engineering and Particle Technology at the Hamburg University of Technology (Germany).

About the product:



CE 400 Gas absorption

Absorption processes are used in air pollution control. One typical application is cleaning exhaust air for the desulphurisation of gases in power stations. The CE400 trainer allows you to clearly demonstrate the complex theoretical fundamentals of this process in the laboratory.

The device is designed for the absorptive separation of carbon dioxide from an airflow. Water is used as solvent for absorbing the carbon dioxide. This ensures safe operation for the device user.

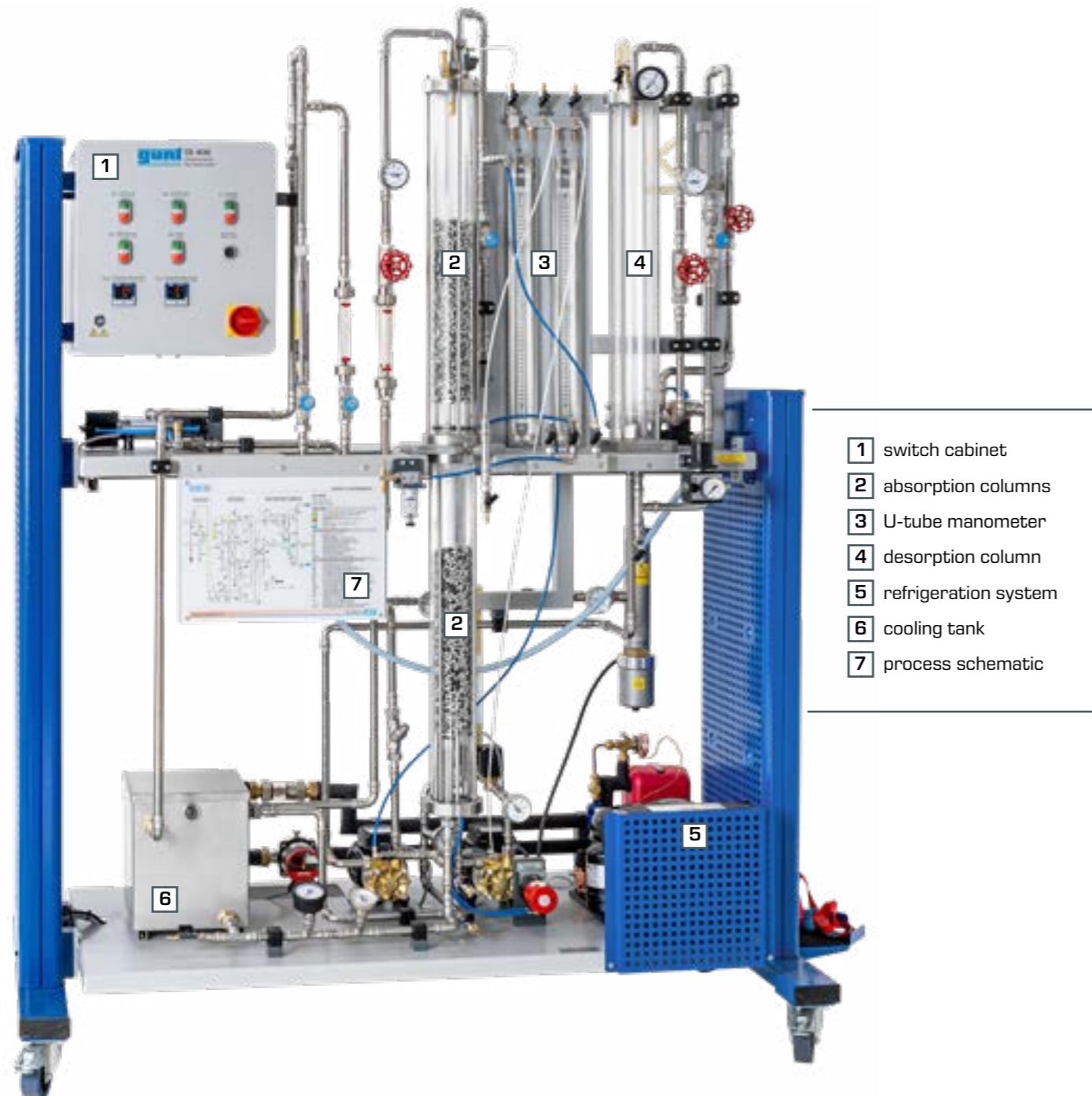

- 1 switch cabinet
- 2 absorption columns
- 3 U-tube manometer
- 4 desorption column
- 5 refrigeration system
- 6 cooling tank
- 7 process schematic

Principle of operation

The main components of the device are two absorption columns filled with Raschig rings. The previously-cooled air/CO₂ mixture is fed into the absorption columns from below. The solvent (water) trickles downwards in the opposite direction through the absorption columns, whereby the carbon dioxide is dissolved in the water. The water enriched with carbon dioxide in this way can then be regenerated in a desorption column and is then available for absorption again.

Instrumentation

The device is equipped with extensive instrumentation and control technology. All relevant flow rates, temperatures and pressures are continuously measured and displayed. The absorption columns are each equipped with a U-tube manometer to measure the differential pressures. You can check the success of the absorption process using the supplied gas analyser. Therefore you do not need any additional instrumentation in order to obtain quantifiable results.



Gas analyser for determining the oxygen content and carbon dioxide content.

About the product:



UNIVERSITY OF Hull

CE 400 is used in many universities worldwide, for example at the University of Hull (England).



A GUNT employee explains the functional principle of CE400 gas absorption to lecturers at the University of Hull.

Learning objectives

- investigation of the absorption process when separating gas mixtures in a packed column
- determination of pressure losses in the column
- representation of the absorption process in an operating diagram
- investigation of the variables influencing the effectiveness of absorption

CE 540 Adsorptive air drying

Adsorption processes are used in air pollution control. A typical example is the removal of hydrocarbon contaminants, such as those occurring during painting and printing processes. The CE 540 trainer allows you to clearly demonstrate the complex theoretical fundamentals of this process in the laboratory.

The device is designed for the adsorptive separation of moisture from an airflow. Silica gel is used as adsorbent for absorbing the moisture. This ensures safe operation for the device user. The silica gel discolours as the load increases, which also makes the adsorption process clearly visible.

- 1 adsorption columns
- 2 humidifier (water bath)
- 3 compressor for supply air
- 4 refrigeration system
- 5 flow meter
- 6 switch cabinet
- 7 heater for regeneration air

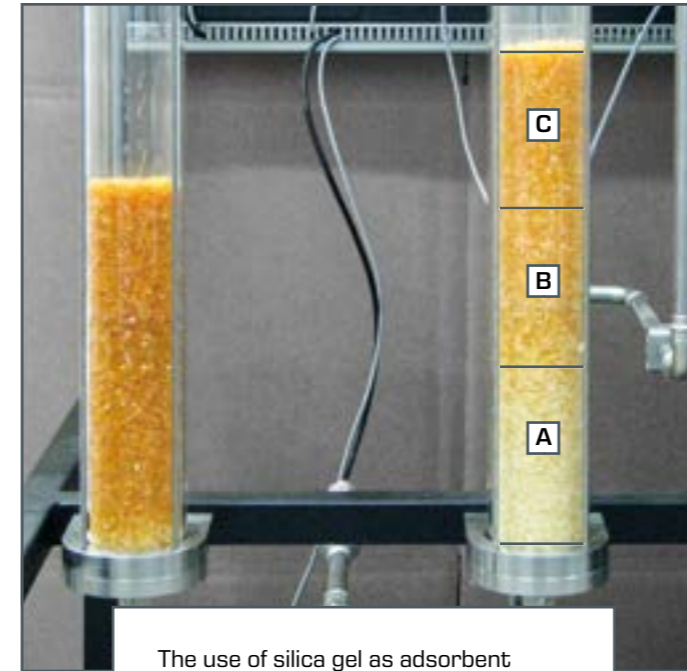

The use of silica gel as adsorbent makes the three zones in an adsorber clearly visible:

- A loaded silica gel
- B partially loaded silica gel (mass transfer zone)
- C unloaded silica gel

Principle of operation

The main components of the device are two columns filled with silica gel. First the moistened ambient air is fed into the columns by a compressor. Here the silica gel adsorbs the moisture present in the air. The silica gel can be regenerated once its maximum load is reached. The silica gel is regenerated via the passage of heated air. In this process, the silica gel returns to its original colour and can be used again. No consumables subsequently requiring disposal are used during this process.

Instrumentation

Temperatures and moisture levels are measured at all relevant points. This allows you to draw up a full balance for the process.

Software

The clearly-arranged software included with CE 540 displays all measured values continuously. The software also functions as a controller for the temperature and moisture in the inflow of the adsorber. You can of course save all measured values for later analysis.

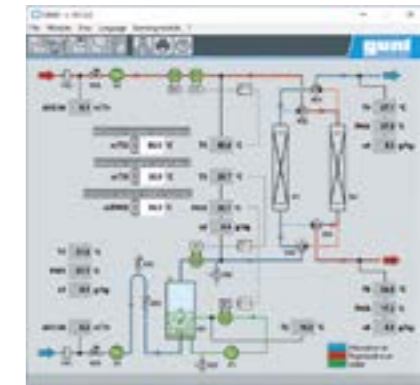

Learning objectives

- fundamental principle of adsorption and desorption
- investigation of the variables influencing adsorption and desorption
 - ▶ airflow rate
 - ▶ air humidity and temperature
 - ▶ bed height of adsorbent
- depiction of the processes in a h-x diagram
- plotting of breakthrough curves
- determination of breakthrough time

About the product:



Introduction

Subject areas	
Soil	072

Hydrogeology

Basic knowledge	
Hydrogeology	074

HM 165

Studies in hydrology	076
----------------------	-----

HM 141

Hydrographs after precipitation	078
---------------------------------	-----

HM 167

Ground water flow	080
-------------------	-----

HM 169

Visualisation of seepage flows	082
--------------------------------	-----

CE 117

Flow through particle layers	084
------------------------------	-----

Soil treatment

Basic knowledge	
Soil treatment	086

CE 225

Hydrocyclone	088
--------------	-----

CE 630

Solid-liquid extraction	090
-------------------------	-----



Subject areas
Soil

Subject areas

Products

Complex processes which can have a negative impact on this habitat take place in the soil. For budding engineers and specialist technicians in the field of environmental engineering, it is therefore necessary to develop an understanding of these processes. The subject areas in the soil area comprise hydrogeology and soil treatment.

Hydrogeology

In the field of hydrogeology, we offer selected training equipment which will help you to teach the basic hydrogeological processes in soils in a practical and clear manner. Issues such as seepage of precipitation, seepage flows and groundwater flows are studied. Other devices of interest on these and related topics can be found in our product range "Hydraulics for civil engineering".

Soil treatment

In this subject area you will find selected teaching devices which cover the processes typically used in the treatment of contaminated soils. Most of these processes have their origins in classical process engineering. Our complete range can be found in our product range "Process engineering".

Hydrogeology

HM 165

Studies in hydrology

HM 141

Hydrographs after precipitation

HM 167

Ground water flow

HM 169

Visualisation of seepage flows

CE 117

Flow through particle layers

Soil treatment

CE 225

Hydrocyclone

CE 630

Solid-liquid extraction



4

Hydraulics
for civil engineering» Hydraulics for
civil engineering

5

Process engineering

» Process
engineering

Basic knowledge Hydrogeology

What is hydrogeology?

Hydrogeology is an applied discipline of geosciences. Unlike hydrology, which deals with above-ground water, hydrogeology covers all aspects which are related to water contained in the ground. These include the following topics in particular:

- seepage and storage of precipitation
- flow processes in soils (e.g. seepage flows)
- regeneration, flow and pumping of groundwater
- drainage measures
- impact of construction on the hydrogeological conditions in the ground

Flow processes in soils

Flow processes in soils are of central importance in hydrogeology. Such flow processes take place in different soil layers. We must always distinguish between the unsaturated and saturated soil zones. The upper layer is usually not completely saturated with water, so some pores also contain air. Below this region is a soil zone whose pores are completely filled with water. This zone is therefore also referred to as the saturated soil zone.

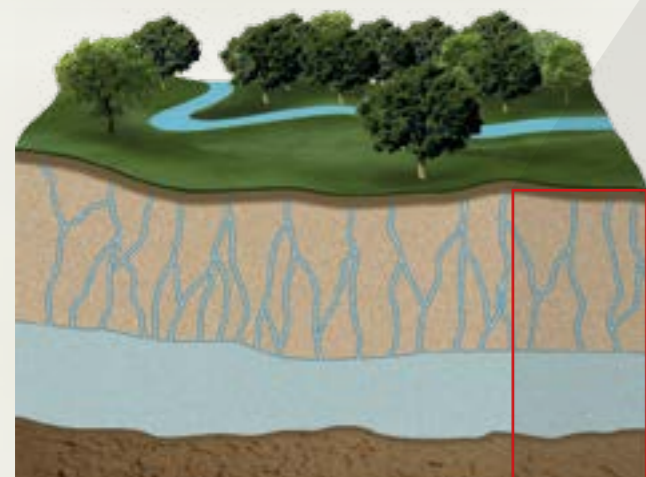

Basic knowledge of these topics is necessary, for example in the exploration, evaluation and use of groundwater resources. Other applications include the protection of groundwater through safeguarding and remedial measures and the drainage of precipitation.

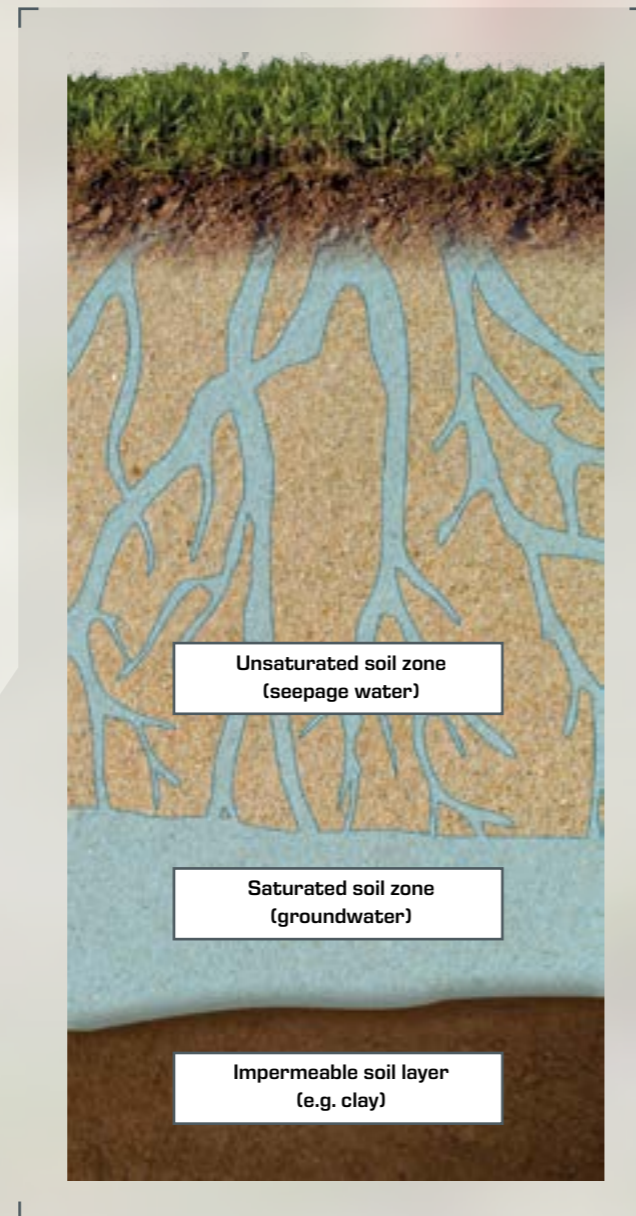

Groundwater: vital reservoir

Groundwater is underground water which fills the pores of the earth's crust and whose possibility for movement is determined solely by the force of gravity. Groundwater fulfils many important functions, for example as a reservoir for drinking water production. Furthermore, an intact groundwater table is an important component of the global water cycle.

Interventions in hydrogeology

In the past, the improper handling of chemicals has allowed many toxic substances to enter groundwater. The aim of sustainable environmental engineering is therefore to provide a sustainable use of groundwater whilst largely avoiding the harmful effects on the groundwater table at the same time. Where contaminants have already entered the groundwater, safeguarding or remedying of the affected area is required to prevent further spread of the contamination.

Many structural measures affect hydrogeological conditions in the soil. Therefore such construction projects require solid hydrogeological knowledge and must be planned with great care.

For example, the extraction of groundwater by production wells results in a funnel-shaped lowering of the groundwater level.

In structures where flow passes underneath or through, such as sheet piles and dams, exact knowledge of the course of seepage flows is a crucial factor in the stability of the structures. Such structures must therefore be realised while taking the hydrogeological impact into account.

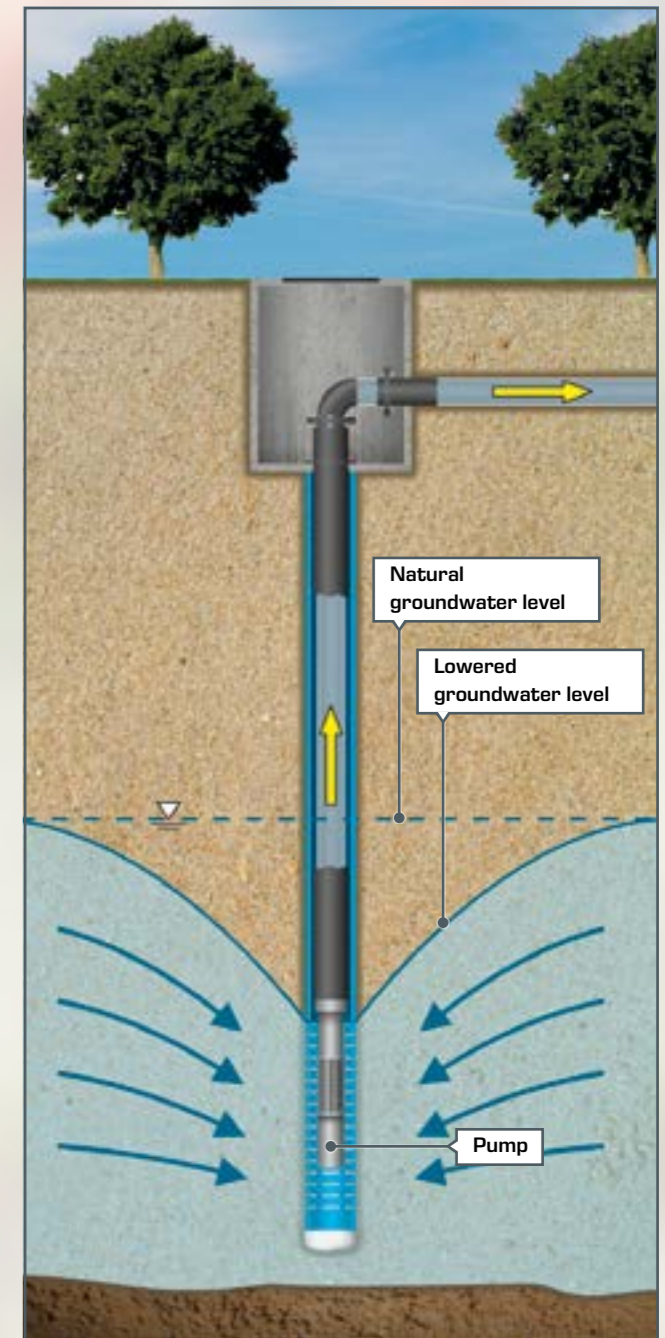

Depression cone in the extraction of groundwater

HM165 Studies in hydrology

Hydrological studies are conducted in connection with the design, construction and operation of hydraulic engineering systems and water management functions. These studies focus on topics such as seepage and flow of water in the soil and the use of groundwater resources.

This device can be used to study seepage and groundwater flows after precipitation. In particular, the permeability and storage capacity of soils can easily be observed. Many adjustable parameters allow a wide range of experiments.



Precipitation device with nozzles for realistic simulation of rainfall



19 tube manometers allow very detailed measurement of the groundwater level.

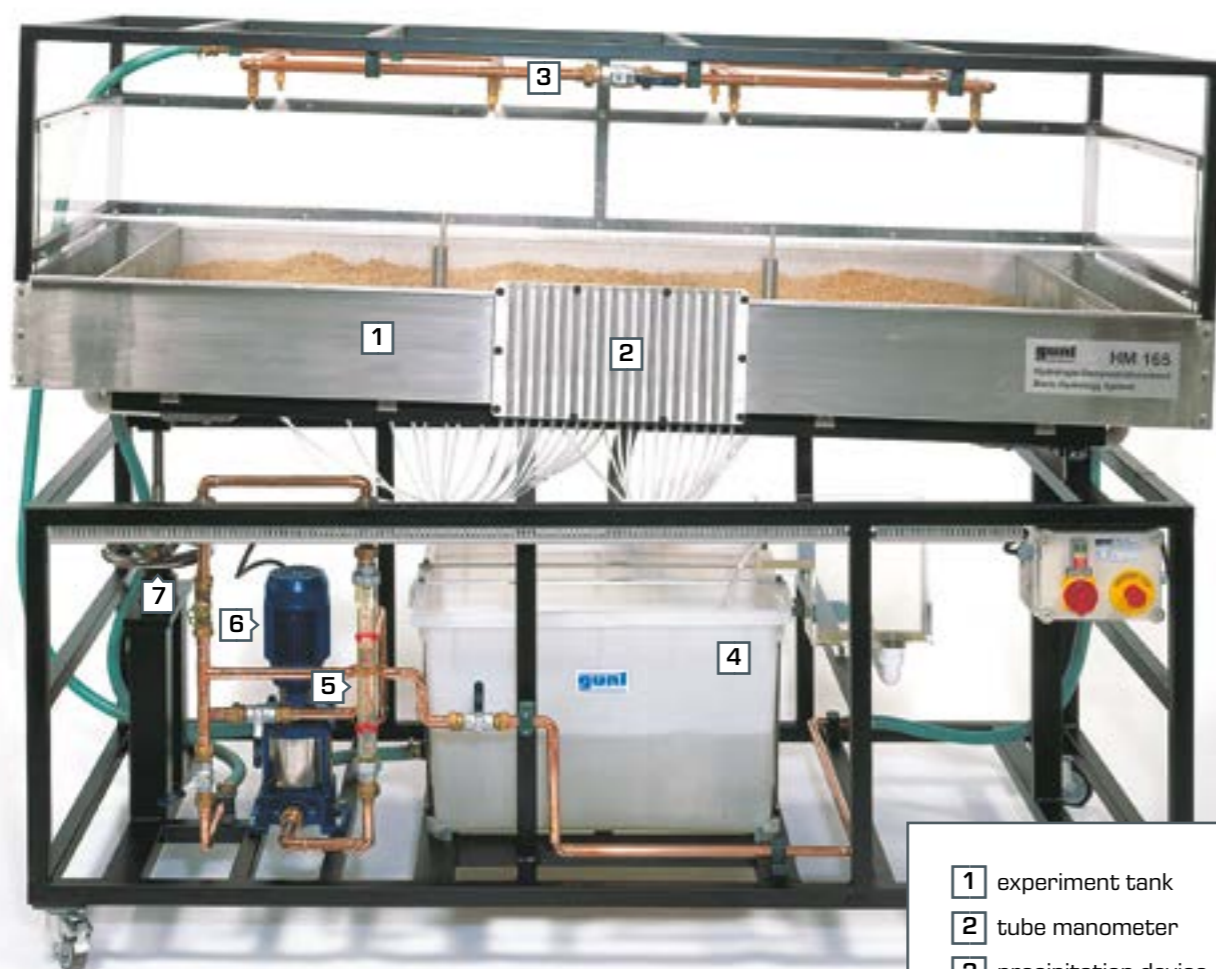

- 1 experiment tank
- 2 tube manometer
- 3 precipitation device
- 4 storage tank
- 5 flow meter
- 6 pump
- 7 inclination adjustment

To illustrate groundwater flow, the water is supplied to the experiment tank via two side-mounted chambers. A precipitation device is available for studying precipitation. There are two wells with perforated tubes or two side-mounted chambers with drainage screens available for the investigation of various drainage systems. At the bottom of the experiment tank are 19 connections for measuring groundwater levels which are indicated on tube manometers.

With this device you also receive comprehensive instructional material. A detailed description of selected experiments enables you to quickly incorporate the device into your teaching.

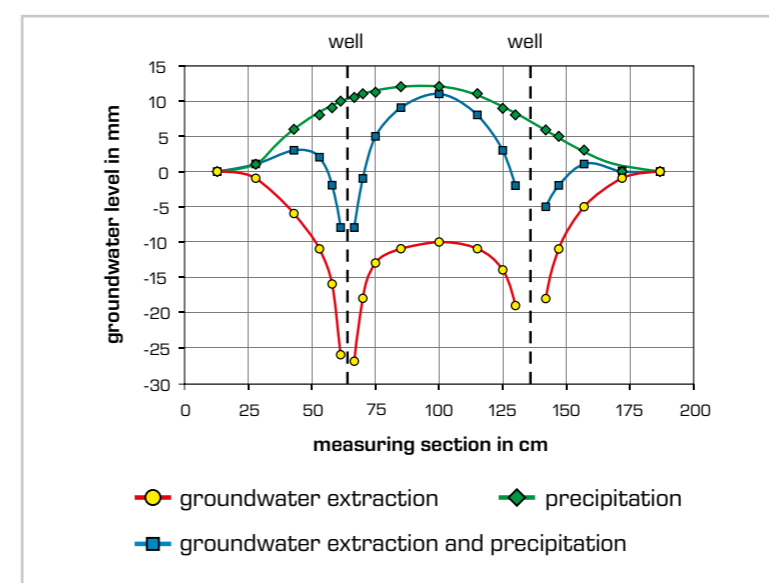

Excerpt from the HM165 manual: measured island groundwater levels for three different scenarios.



Learning objectives

- investigating transient processes
 - ▶ studying how precipitation of varying duration affects drainage
 - ▶ storage capacity of a soil
- investigating steady processes
 - ▶ investigating the seepage flow
 - ▶ effect of different soil saturation levels

About the product:



HM 141 Hydrographs after precipitation

Hydrographs are an important tool for the representation of hydrological data such as precipitation, groundwater levels or drainage. Furthermore, a hydrograph is the basis for the design of sewer systems. In this case, the progress of the amount of precipitation over time is just as important as the quality of the soil.

i Hydrograph

A hydrograph is defined as the graphical representation of drainage (for example in m^3/h) at a particular measuring point as a function of time.



The core element of HM 141 is an experiment tank filled with sand or gravel. Using timers, you can apply precipitation to the experiment area with varying duration and intensity. The drainage of the experiment area can be implemented either with a drainage tube or a drainage chamber located at the side of the experiment tank.

The water draining from the experiment tank is filled successively into 17 measurement chambers controlled by time. Determining the amount of water in the individual measurement chambers allows you to determine the timing of drainage from the experiment area, i. e. the hydrograph.



The measuring chambers are filled successively in a time controlled manner.

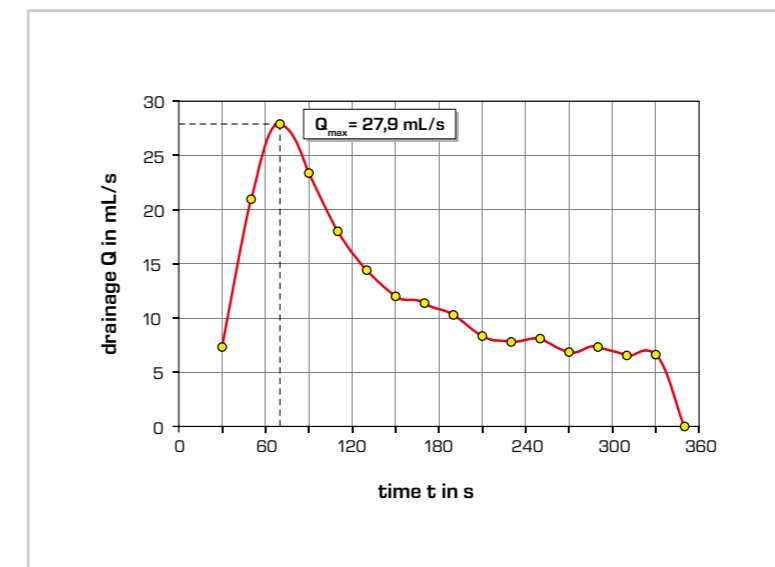

Excerpt from the HM 141 manual: typical hydrograph curve with drainage via lateral outflow chambers. The maximum drainage occurring in this precipitation event can be determined from the hydrograph.

Learning objectives

- effect of precipitation of varying duration or intensity on soils with different saturation
- record hydrographs after precipitation
- compare natural dewatering with dewatering via drainage pipe
- influence of rainwater retention basin on the hydrograph

About the product:



HM167 Ground water flow

Many structural measures have an impact on the groundwater level. This may be the case for example in usage of groundwater, in flood prevention or in remedial measures. Exact knowledge of the effects of such structures on the groundwater level is therefore an important foundation for planning for environmental engineers.

We have developed our HM167 device in order to practically teach such issues. The trainer allows you to represent typical structural scenarios and to investigate their influence on the groundwater flow in three dimensions.

The core element of HM167 is an experiment tank filled with sand or gravel. You can use different models in the experiment tank to simulate structures. The models can be used to study dykes, excavation pits and wells.



Models for installation in the experiment tank

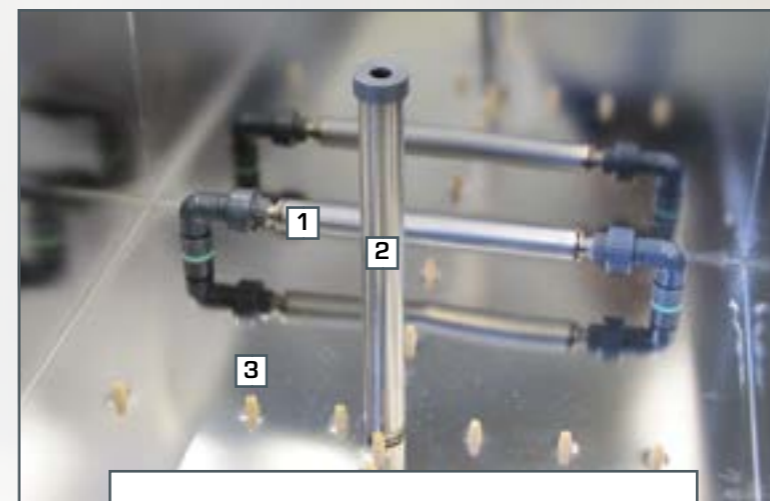

- 1 experiment tank with water supply
- 2 well
- 3 measuring points for groundwater level



The experiment tank is fitted with an inlet at both ends. The study of various drainage processes is made possible by two wells. You can activate the inlets and wells independently of each other. This results in many experimental possibilities.

In order to determine the groundwater levels, the experiment tank is equipped with a total of 19 measurement points. The groundwater levels are clearly displayed on tube manometers. In addition to the tube manometers, scales on the side allow for easy and accurate reading of groundwater levels.

Learning objectives

- determining the groundwater level
- lowering of groundwater level via two wells
- groundwater flow on excavation pits
- groundwater studies under concentric load on the substrate

About the product:



HM 169 Visualisation of seepage flows

Seepage flows – protection of groundwater and structures

Seepage flows play a crucial role during construction in water-bearing layers. On the one hand, the flow through and flow around structures is relevant. On the other hand, the hydrostatic pressure acting on the structures is also of interest.

A descriptive method in the study of seepage and groundwater flow is the visualisation of the streamlines and their graphical representation as a flow net. The flow net provides information about the seepage of water through structures such as dams and sheet piles.

Our HM 169 device allows you to clearly visualise and investigate streamlines around structures. To do this, various models of typical structures which you can easily insert into the experimental section are available.

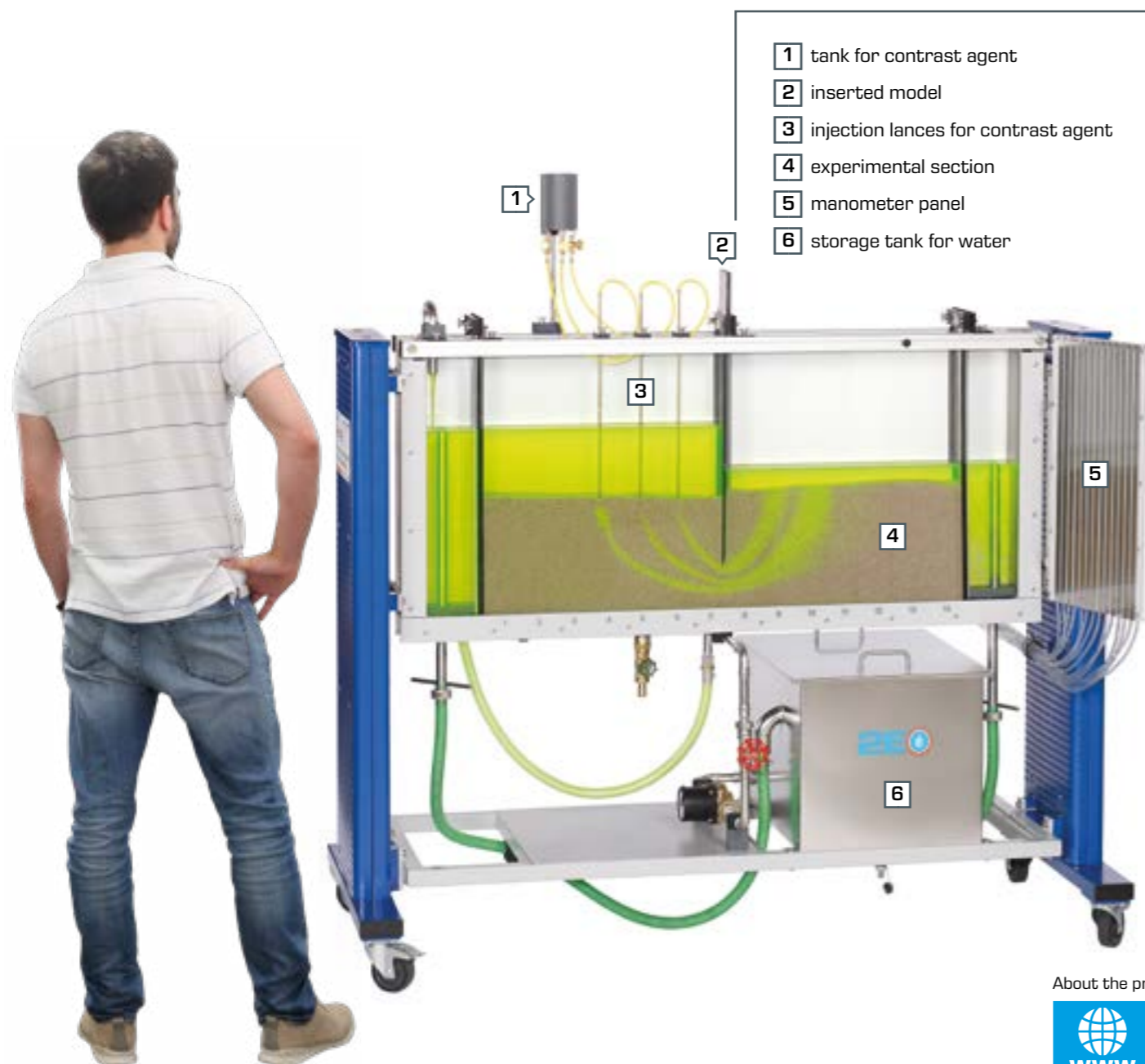

About the product:

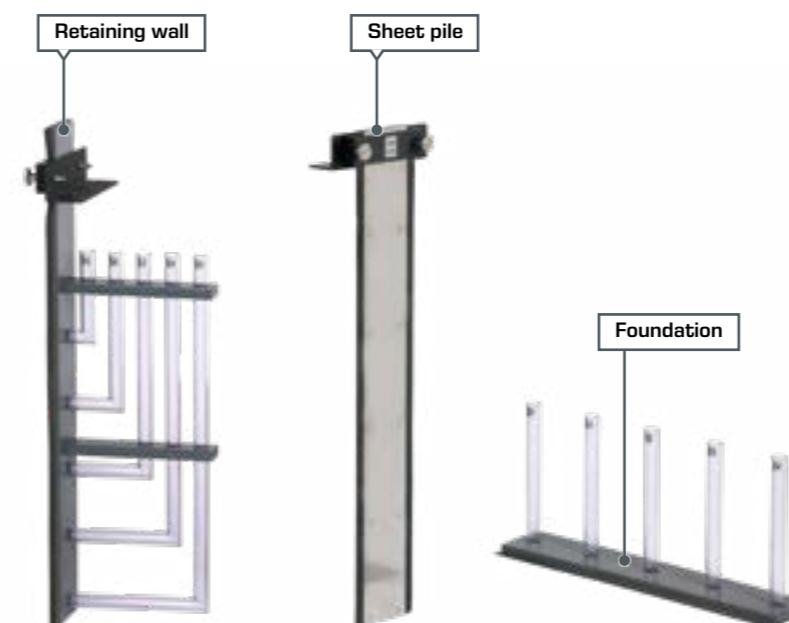

By injecting a contrast agent, such as fluoresceine or ink, the streamlines can be made very clearly visible. The pressure curves of these structures are also displayed in both the "retaining wall" and "foundation" models. The groundwater levels in the experimental section can be measured easily and with great accuracy by using tube manometers.



The possibilities of HM 169 are demonstrated to interested members of staff at Regensburg University of Applied Sciences (Germany).

Learning objectives	
■	determining flow nets in permeable media graphically <ul style="list-style-type: none"> ▶ streamlines under a sheet pile ▶ streamlines through an dam ▶ drainage at an open ditch
■	determining the pressure curve at a foundation
■	determining the pressure curve at a retaining wall
■	groundwater levels over time in various models

CE117 Flow through particle layers

Seepage flow

In hydrology, seepage flow refers to the flow of a fluid (water) in permeable soil layers such as sand. The fluid fills the pores in the unsaturated bottom layer and moves into the deeper layers as a result of the effect of gravity. The soil has to be permeable so that the seepage water is not stored.

In less permeable soils the seepage water can be stored temporarily. If the seepage water encounters an impermeable soil layer or impermeable rock, seepage will no longer take place and the seepage water accumulates permanently. Such underground water accumulations are known as groundwater. In hydraulic terms, seepage flow corresponds to the flow through a particle layer.

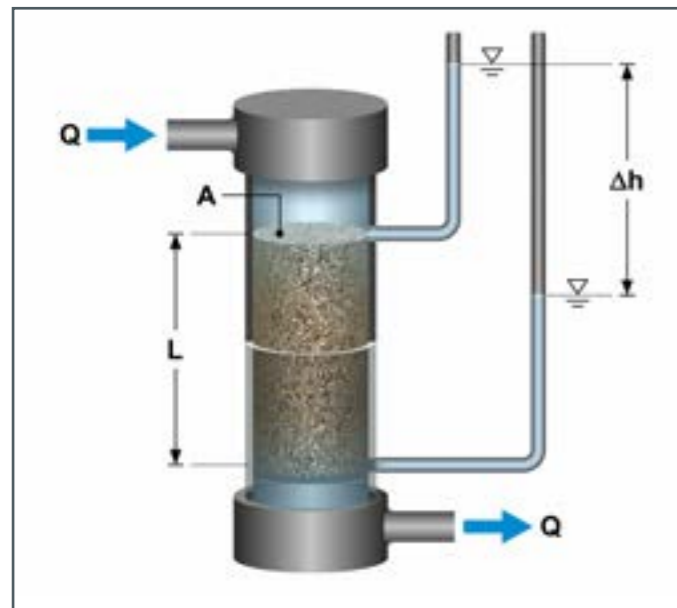

Flow through a particle layer

Darcy's law

Exploration of the fundamental relationships in flow through particle layers goes back to **Henry Darcy** (1803-1858).

As flow passes through a particle layer, the particle layer resists the flow, which leads to a pressure loss. **Darcy** found that with laminar flow there is a linear relationship between the flow rate Q and the pressure loss (differential pressure head Δh).

$$Q = k_f \cdot A \cdot \frac{\Delta h}{L}$$

The dimensionless variable $\Delta h/L$ is denoted as the hydraulic gradient. The permeability is described by the coefficient of permeability k_f in the unit m/s and is dependent on the grain size and the useful pore space.

Experimental unit CE 117

The experimental unit CE 117 can be used to investigate the fundamental fluid mechanics of flow through packed beds. The experimental unit has a transparent test tank which allows optimal observation of the processes. To determine the pressure loss, two manometers with differing measuring ranges are provided.

The experimental setup can be modified by means of quick-release couplings. This also enables the flow through the test tank to be reversed and fluidised beds to be investigated. The flow rate is adjusted by a valve and indicated by a flow meter.

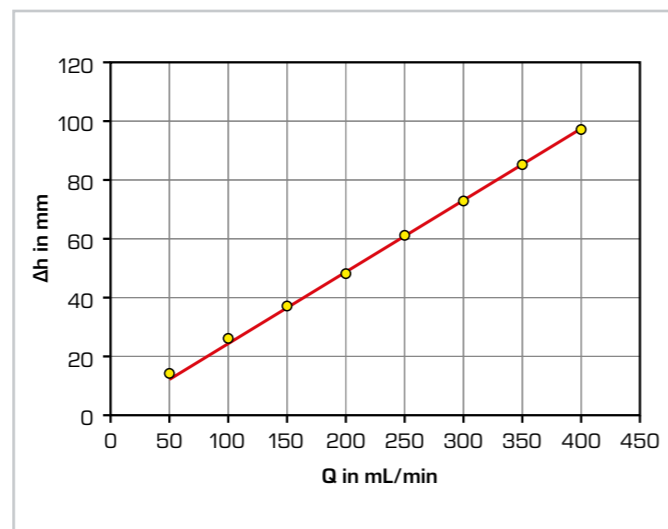

Measured differential pressure head Δh as a function of the flow rate Q (sand: $d = 1..2$ mm, $L = 60$ mm)

- experiments in the fundamentals of fluid mechanics on particle layers
- flow through fixed beds
- flow through fluidised beds
- pressure loss in fixed beds and fluidised beds

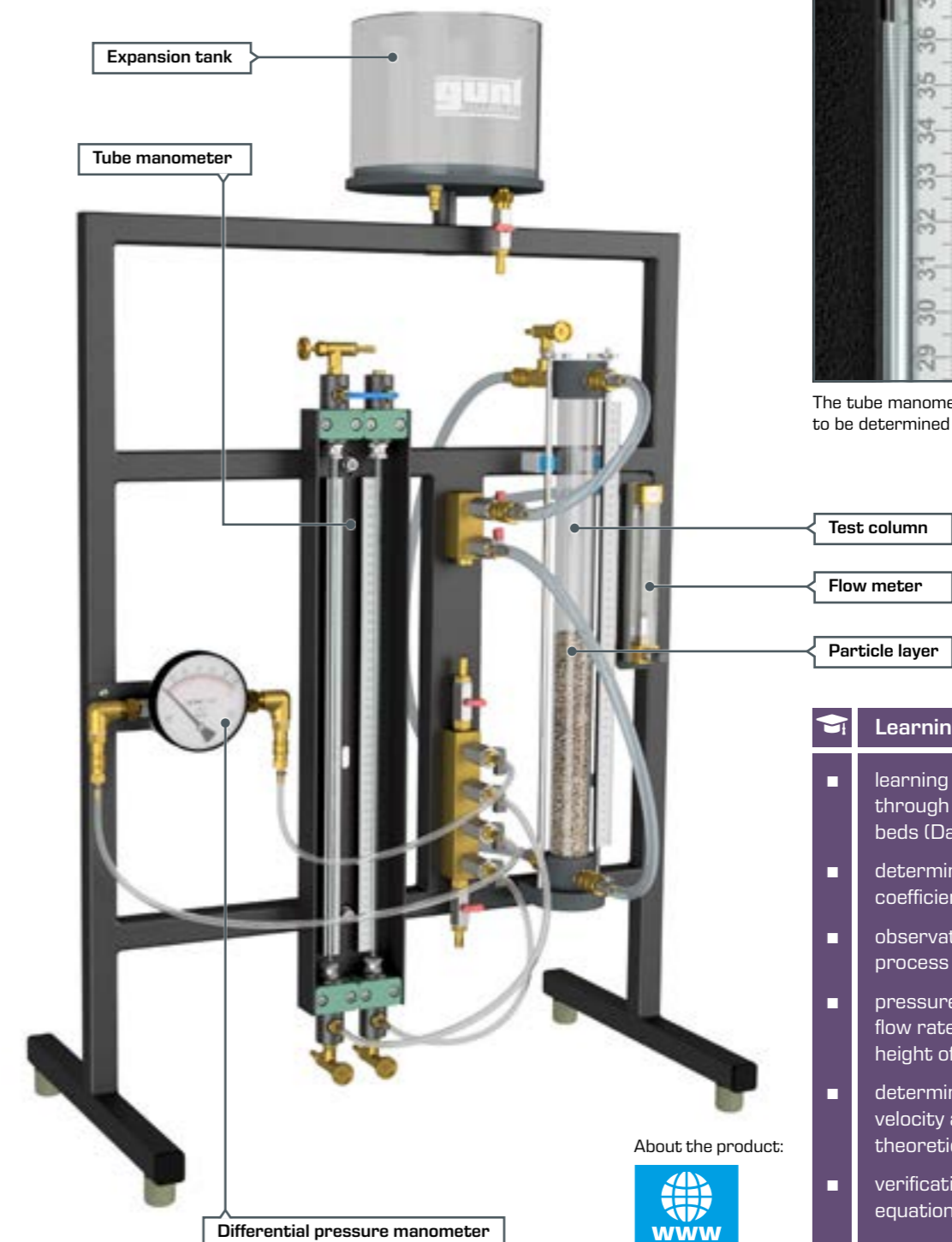

The tube manometer enables low pressure losses to be determined with a high degree of accuracy.

Learning objectives

- learning the fundamentals of flow through fixed beds and fluidised beds (Darcy)
- determination of the permeability coefficient
- observation of the fluidisation process
- pressure loss dependent on the flow rate, type, particle size and height of the bulk solid
- determination of the fluidisation velocity and comparison with theoretically calculated values
- verification of Carman-Kozeny equation

About the product:



Basic knowledge

Soil treatment

Contaminants in the soil – a threat to the environment

In the past, the use of environmentally hazardous substances was often not given the necessary attention. This allowed toxic substances, such as chlorinated hydrocarbons, to enter the ground in many places. Much of this contamination comes from landfills and former industrial sites and poses a threat to the environment, and to ground-

water in particular. Remediation of the contaminated soil must be undertaken in such cases. A number of different methods are available depending on the type of soil and type of contamination.

Soil: a multi-phase mixture

Usually all three phases (solid, liquid and gaseous) are encountered in the soil. Similarly, all three phases can be affected by contamination. Soil treatment requires a holistic approach which takes all three phases in the soil and their complex interactions into account.



Treatment of contaminated soils: a complex task

The main objective of soil treatment is to protect the groundwater and – as far as possible – to restore the original function of the contaminated soil. Due to the fact that all three phases can be affected by the contamination, soil treatment is a very complex task.

In addition to the contaminated soil, loaded contaminated water and exhaust air also usually occur during treatment. These also require treatment, for which, in turn, current processes of water treatment and air pollution control are used. Fundamentally, two different approaches can be distinguished in soil treatment:

In-situ

The treatment takes place directly in the soil, i.e. at the site of contamination.

Ex-situ

The contaminated soil is removed and treated externally in a plant.

In-situ soil treatment

In-situ treatment of soils is particularly suitable for the liquid and gaseous phase:

- **liquid phase:** pump and treat
- **gaseous phase:** soil vapour extraction

In both methods, the fluid is pumped out of the ground, the contaminants separated from the fluid and the cleaned fluid then passed back into the soil. The separation of contaminant and fluid is performed either with conventional methods for water treatment (pump and treat) or with the processes of air pollution control (soil vapour extraction).

Ex-situ soil treatment

In the ex-situ treatment of soils the contaminated soil is firstly removed. Then the soil is treated in special plants. Most methods used here have their origins in the field of mechanical or thermal process engineering. Typical processes used for soil treatment include:

- comminution
- screening
- solid-liquid separation
- separation of small particles (e.g. with hydrocyclone)
- solid-liquid extraction



CE 225 Hydrocyclone

Hydrocyclones in soil treatment

Experience has shown that contaminants in contaminated soils are mainly bound to finer particles and organic components. Hydrocyclones can be used to separate these fine particles in order to subsequently treat them with other processes, such as solid-liquid extraction.

With our CE 225 trainer, you can clearly demonstrate and investigate how a hydrocyclone works in a practical manner. You are assisted in this task by the comprehensive instructional material, which also gives suggestions on conducting experiments.



The core element of CE 225 is the transparent hydrocyclone for optimal observation of the separation process

The device features a large storage tank, in which the suspension to be separated is positioned. The cyclone is made of transparent material to make the separation process optically visible. The flow rate in the inlet of the cyclone can be adjusted individually and is measured by an electromagnetic flow meter.

You can take samples from all relevant points of the device in order to assess the experiments quantitatively.

Learning objectives

- fundamental principle and the method of operation of a hydrocyclone
- solid mass flow rate in feed, top and bottom flow
- liquid mass flow rate in feed, top and bottom flow
- characteristic values for sharpness of separation
- pressure loss at the cyclone dependent on the feed flow rate
- influence of solids density on characteristic values and pressure loss

About the product:



This device has been developed by our experienced engineers in collaboration with the Institute of Mechanical Process Engineering at the Anhalt University of Applied Sciences (Germany).

Hochschule Anhalt
Anhalt University of Applied Sciences

CE 630 Solid-liquid extraction

Application of a thermal separation process in soil treatment

Contaminants may be present on the solid particles of the soil in a sorbed state. Solid-liquid extraction enables the separation of these contaminants from the soil particles. A suitable solvent needs to be selected for this process depending on the contaminant and the type of soil.

Our CE 630 teaching device is particularly suited to demonstrating the basic principle of this process practically and clearly. You can use the device either in continuous or discontinuous mode. In addition, you can adjust the temperature of the solvent.

- 1 process schematic
- 2 container for extraction material (solid)
- 3 solids dispenser
- 4 extractor
- 5 collection tank for extraction residue
- 6 collection tank for extract
- 7 storage tank for solvent
- 8 switch cabinet with control elements and digital displays



About the product:

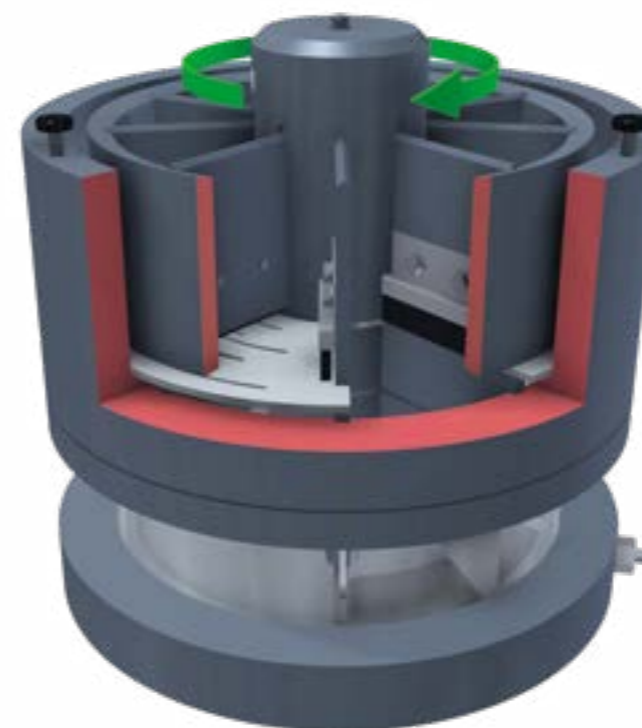

Rotating extractor

The main component of CE 630 is a rotating extractor, which is divided into several chambers. The extraction material, i.e. the solid with the substance to be eliminated, enters these chambers. The solvent enters the chambers from above via three sprinklers and absorbs the material to be extracted. A 3-stage process control is possible due to the rotation of the extractor. You can adjust the speed of the extractor.

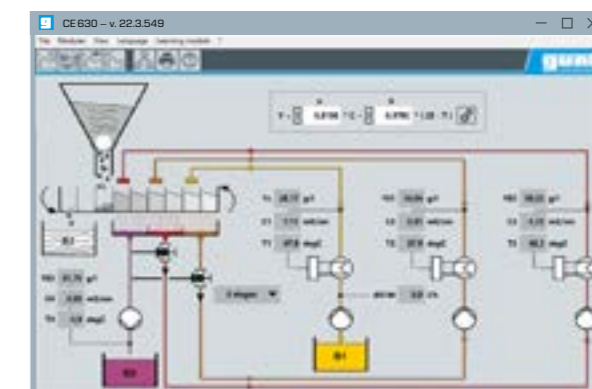

Software

The device is equipped with software which displays all key process variables continuously. You can save the recorded measured values to analyse the experiments.



A satisfied lecturer at the Industrial College in Yanbu (Saudi Arabia) after successful commissioning of CE 630



Learning objectives

- basic principle of solid-liquid extraction
- influence of operation mode (continuous/discontinuous)
- investigation of the 1-stage, 2-stage and 3-stage process
- typical parameters influencing the process:
 - ▶ solvent flow rate
 - ▶ solvent temperature
 - ▶ extraction material flow rate
 - ▶ extractor speed

Introduction	
Subject areas Waste	094
Basic knowledge Waste	096

Comminution	
CE 245 Ball mill	098

Separation processes	
CE 280 Magnetic separation	100
CE 275 Gas flow classification	102
MT 174 Sorting plant	104



Subject areas
Waste

 Subject areas

Products

Comminution

The comminution of waste materials plays a key role in waste management and is a prerequisite for many recycling processes. Comminution prepares waste materials for subsequent process steps. Ball mills are a traditional method for the comminution of solids. Our CE 245 experimental unit clearly demonstrates this process.

Comminution

CE 245
Ball Mill

Separation processes

Separation processes are used to divide mixed waste into separate fractions. The separation can be carried out according to material characteristics (materials) or geometrical characteristics (particle size).

One classic example is separation of metals for subsequent feeding into a recycling process. The separation of metals is usually carried out with magnetic separators. Our CE 280 trainer allows you to clearly demonstrate this separation process in the laboratory.

In gas flow classification, however, the individual fractions of a waste mixture are separated in terms of their geometric characteristics. We have developed our CE 275 zigzag sifter in order to clearly teach the fundamentals of this process.

Separation processes

CE 280
Magnetic Separation
CE 275
Gas Flow Classification
MT 174
Sorting plant

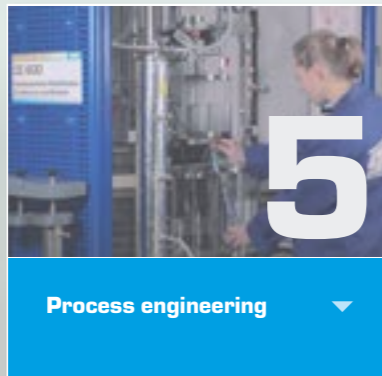

5
Process engineering

Many processes used in waste management have their origins in conventional process engineering. Separation processes, especially from mechanical process engineering, are put to use. Other devices of interest from this field of process engineering can be found in our product range "Process engineering".



» Process engineering

Basic knowledge

Waste

Waste in the economic cycle

Every resident in Germany produces approximately 500-600 kg of domestic waste each year. This waste consists of a wide variety of materials and represents an important resource for the procurement of raw materials for the economy. Waste legislation in Germany is regulated by the Waste Management Act. The main objective of the law is to promote conservation of natural resources by reusing and recycling waste, and to ensure protection of human health and the environment in the production and management of waste.

1	Waste prevention
2	Preparation for reuse of waste
3	Recycling waste
4	Other recovery of waste (e.g. energy)
5	Disposal of waste

The 5-stage waste hierarchy

A key aspect of the Waste Management Act is the 5-stage waste hierarchy. According to this hierarchy, prevention of waste has top priority (1). If production of waste is unavoidable, then reusing the waste through cleaning or repair should be strived for (2). If direct reuse of used products is not possible, these have to be recycled, sorted in accordance with material properties (3). If this is not possible or uneconomical, the waste is exploited in other ways (4), such as for energy. The bottom of this hierarchy is the disposal of waste (5), which usually takes place in landfills.

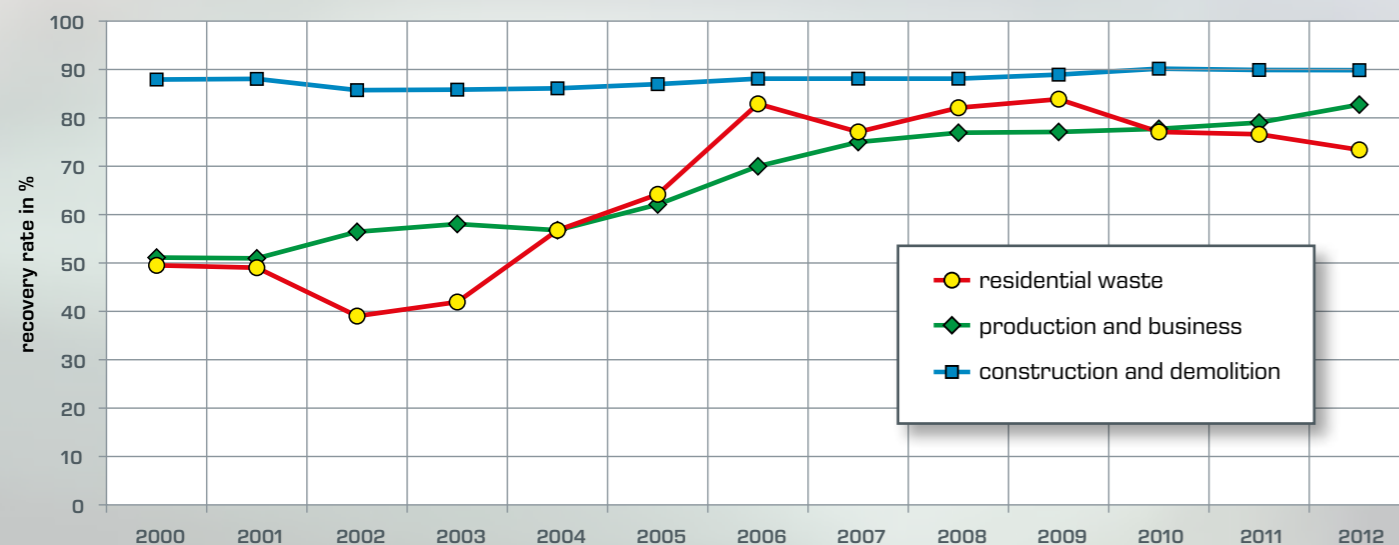

Recovery rates of the most important types of waste in Germany
Source: Federal Statistical Office, Wiesbaden, waste balance, various years; Federal Environment Agency, own calculations

Comminution: prerequisite for effective recycling

The comminution of waste plays a key role in waste management. Comminution reduces the particle size of the waste materials. Simultaneously, comminution leads to an increase of the specific surface area of the particles. Comminution is normally a pre-treatment which is followed by subsequent process steps. For example, the melting of plastics is made easier by a small particle size. Various technologies are used for comminution of waste, such as ball mills.



Gas flow classification

- 1 mixed waste
- 2 zigzag sifter
- 3 gas cyclone
- 4 fan
- 5 tank for fine material
- 6 tank for coarse material

Magnetic separation

Magnetic separation is a separation process in which the magnetisation of components (e.g. iron) of a waste mixture is exploited. The waste mixture is conveyed to a rotating, non-magnetic drum. In one area of the drum there is a permanent magnet that sticks the magnetisable parts to the drum and carries them along. The non-magnetisable parts fall into a collection tank due to gravity. The magnetisable parts are detached from the drum once they leave the permanent magnet's sphere of influence and drop into another collection tank.

Gas flow classification

This separation process uses the different settling velocities of particles in an airflow. The settling velocity depends on the size, density and shape of individual particles and on the resulting flow resistance and weight forces. Gas flow classification primarily uses what are known as zigzag sifters. In a zigzag sifter, the waste mixture to be separated is fed in from the side of the zigzag channel in which an air-flow moves upward. Depending on geometry and density, the particles are taken along by the airflow or fall downwards due to gravity. Often, a zigzag sifter is located downstream of a cyclone. This separates the fraction carried along by the airflow so that the air can be fed back into the cycle.

CE 245 Ball mill



Many processes used in the recycling of waste are favoured by a small particle size. Waste usually has to be comminuted first for this reason. Various techniques such as ball mills are used to do this.



Large-scale ball mill in waste management

Our CE 245 experimental unit allows you to teach the fundamentals of this comminution process in practice. There are three different drums available. All drums have transparent faces. This means you can observe the comminution process and the motion states inside the drum which are characteristic of ball mills.

The speed of the ball mill is continuously adjustable. Speed and power consumption of the drive motor are displayed digitally. This allows you to compare the theoretical demand with the actual power demand. You can adjust the desired mill time using a timer.

The instructional material sets out the fundamentals of this process in detail. Example experiments are clearly described and evaluated.



We recommend our CE 264 Screening Machine for analysis of the experiments.

About the product:



 Learning objectives
<ul style="list-style-type: none"> ■ cascade motion ■ cataract motion ■ determining the critical speed ■ comparison of theoretical and actual power demand ■ influence of the following parameters on the degree of comminution: <ul style="list-style-type: none"> ▶ mill time ▶ speed ▶ ball diameter ▶ ball filling ▶ material to be milled

CE 280 Magnetic separation



About the product:



Magnetic separation: recovery of important raw materials

The recovery of reusable materials is a central aspect of waste management. A very effective and therefore widely-used method for separating magnetisable reusable materials such as iron from a mixture of waste is by using magnetic separators.

Magnetic separator CE 280

With our CE 280 trainer, you can clearly demonstrate how a magnetic separator works. The main component is a professional drum-type magnetic separator, as is often used in industry to sort solid mixtures.

The mixture to be separated is fed evenly to the magnetic separator by a vibrating trough. The height-adjustable hopper allows you to adjust the distance between the hopper outlet and the vibrating trough. The amplitude and frequency of the vibrating trough can be individually adjusted. These three settings allow you to control the mass flow rate of the feed material.

You can adjust the speed of the drum-type magnetic separator continuously for studying the influence of speed on the effectiveness of the separation.

Learning objectives

- fundamental principle and operating behaviour of a drum-type magnetic separator
- influence of the following factors on the effectiveness of separation:
 - ▶ mass flow rate of the feed material
 - ▶ mixing ratio of the feed material
 - ▶ type of feed material
 - ▶ drum speed

CE 275 Gas flow classification

Gas flow classification with zigzag sifter: a mechanical separation process

Gas flow classification is a mechanical separation process from the field of conventional process engineering. In waste management, this process is used for the separation of various wastes, for example, to separate dust, sand or non-reusable materials from reusable materials. This is mainly achieved by the use of zigzag sifters.

This teaching unit is perfectly suited to teaching the theoretical fundamentals of this process, clearly and practically. The main element of CE 275 is a 20-stage zigzag sifter, which is equipped with a transparent cover. This allows you to observe the separation process in the zigzag channel over the entire height.

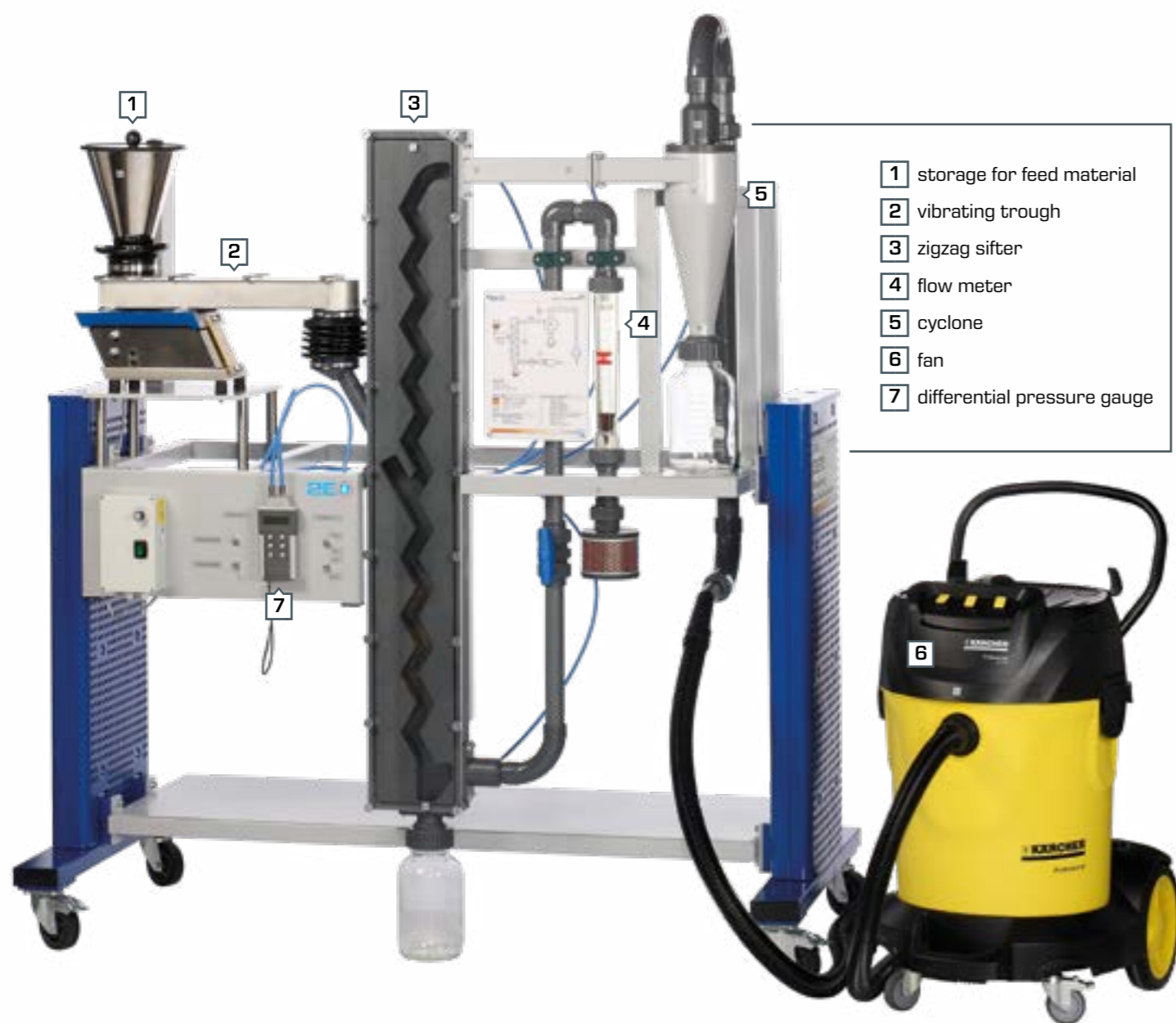

- 1 storage for feed material
- 2 vibrating trough
- 3 zigzag sifter
- 4 flow meter
- 5 cyclone
- 6 fan
- 7 differential pressure gauge

About the product:



Principle of operation

The waste mixture to be separated (feed material) is conveyed evenly into the zigzag sifter by a vibrating trough. The fan generates the upwardly-directed airflow necessary for separation through the zigzag channel. You can adjust the mass flow rate of the feed material and the volumetric flow rate of the air. The fraction of the feed material transported along with the air is then separated in a cyclone. This allows a closed circuit for the air flow. The zigzag sifter and cyclone are each equipped with differential pressure measurement.



CE 275 during a trial run:
The vibrating trough evenly conveys the mixture of spelt husks and cherry stones to be separated from to the zigzag sifter.

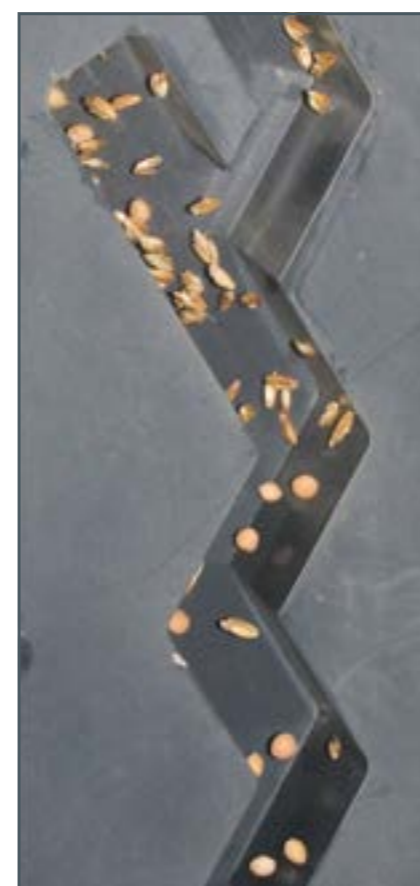

In the zigzag channel,
the separation of the mixture
can clearly be observed.

This device has been developed by our experienced engineers in collaboration with the Institute of Mechanical Process Engineering at the Anhalt University of Applied Sciences (Germany).

Hochschule Anhalt
Anhalt University of Applied Sciences

Recommended accessory



We recommend our CE 264 Screening Machine for analysis of the experiments.

Learning objectives

- familiarisation with the basic principle of gas flow classification
 - influence of the mass flow rate and the airflow rate on
 - ▶ fine material fraction
 - ▶ quality of separation
 - ▶ sifter pressure loss
 - ▶ cyclone pressure loss
 - ▶ fraction balance
 - ▶ separation function
 - ▶ separation size
 - ▶ sharpness of separation
- } with
CE 264

MT174 Sorting plant

The separation of mixtures of waste material into individual fractions of the same properties is an essential part of waste management. It is a requirement of effective recycling processes in order to be able to return recyclable materials to the cycle.

The MT 174 Sorting plant is modelled on a typical separation process from waste management and includes classification by means of a drum screen and colour sorting.

- laboratory scale sorting plant with standard industrial components
- separation into 3 size fractions with drum screen
- colour sorting into 3 fractions
- control of the experimental plant using a PLC, operated by touch screen
- augmented reality for visualisation of maintenance work

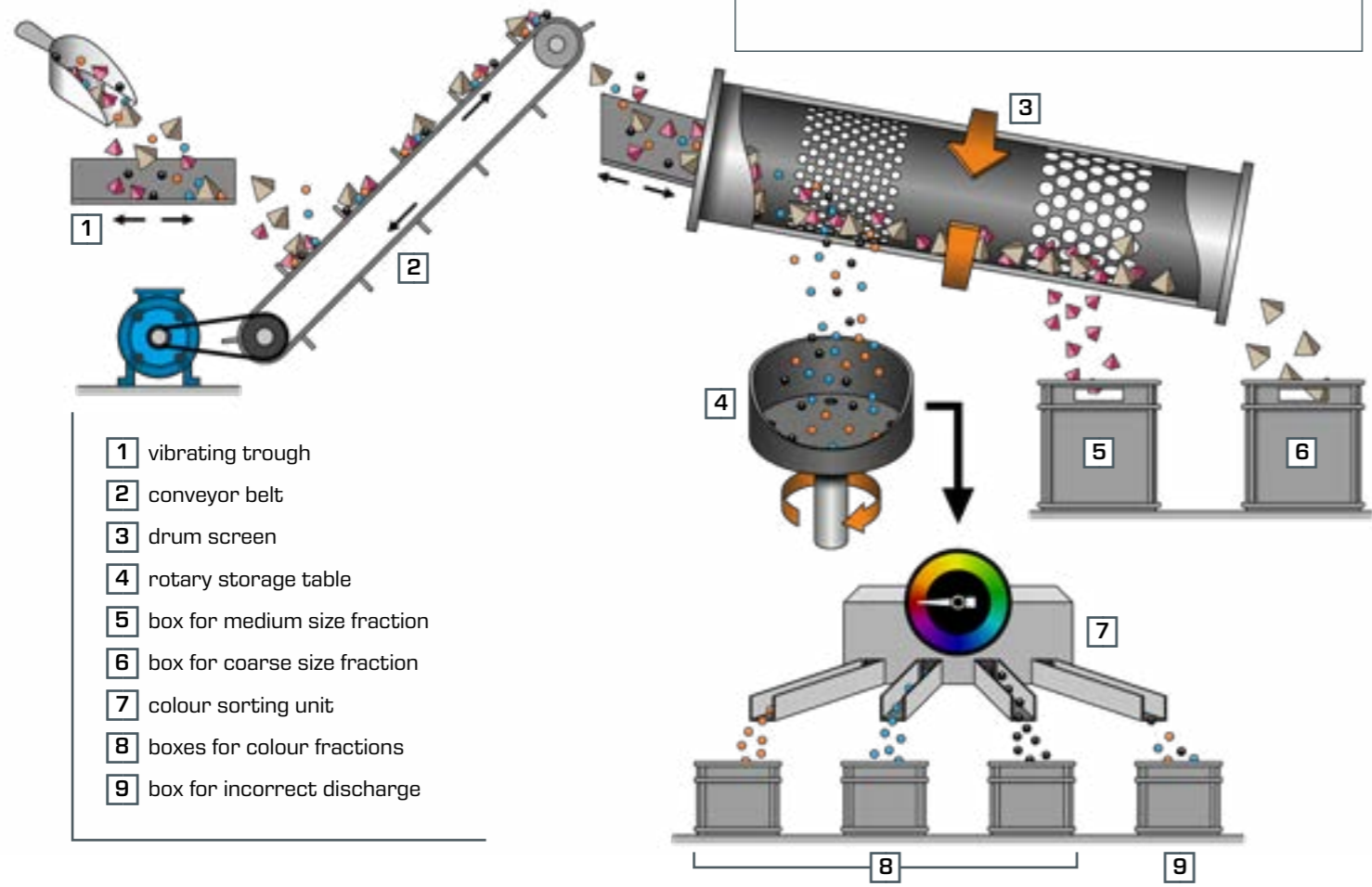

About the product:



PLC with touch screen

The plant is controlled by a modern PLC with touch screen. For the sake of transparency, a separate user interface is provided for each functional group. All parameters relevant to the separation process can be configured using the PLC. These include, for example, the speed and inclination of the drum screen. It is also possible to define the colours of the particles to be sorted in the PLC.

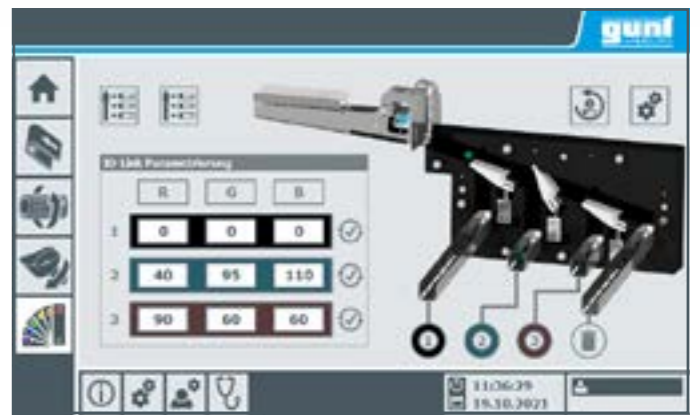

Screenshot from the PLC (colour sorting)

Learning objectives

- influence of the following parameters on the separation process:
 - ▶ conveyor belt speed
 - ▶ inclination and speed of the drum screen
 - ▶ speed of the rotary storage table
 - ▶ frequency of the vibrating troughs
 - ▶ color definition for color sorting
- maintenance work on an industrial plant
 - ▶ time-controlled
 - ▶ sensor-controlled
 - ▶ supported by augmented reality

Maintenance

Maintenance and servicing are prerequisites for the reliable operation of a sorting plant. Which is why it is possible to perform maintenance work on the sorting plant for training purposes. If the plant is operated in training mode, the PLC independently generates time- and sensor-based messages for maintenance work to be carried out. An augmented reality interface is available for mobile devices to visualise the maintenance work.



Drum screen



Rotary storage table and colour sorting

MT174 Sorting plant – GUNT DigiSkills 3

Skill Level				
1	2	3	4	5

The digitalisation in the world of work – new requirements for education

Designing training in industrial metalworking and electrical professions

Standard learning objectives from units of qualifications in industrial mechanics

- fabricate structural elements with hand-held tools or with machines
- manufacture simple assemblies
- manufacture, commission and repair of technical systems
- maintenance of technical systems

New learning objectives concerning Digitalisation of Work

- use standard business software, e.g. ERP, CAD, CAM
- convert data
- use digital technologies and work tools, e.g. LAN/WLAN, QR code, RFID, Bluetooth
- Computer Based Training (CBT) and Web Based Training (WBT)
- work with mobile devices
- augmented reality
- virtual reality
- condition monitoring



Disassembly of the gearbox

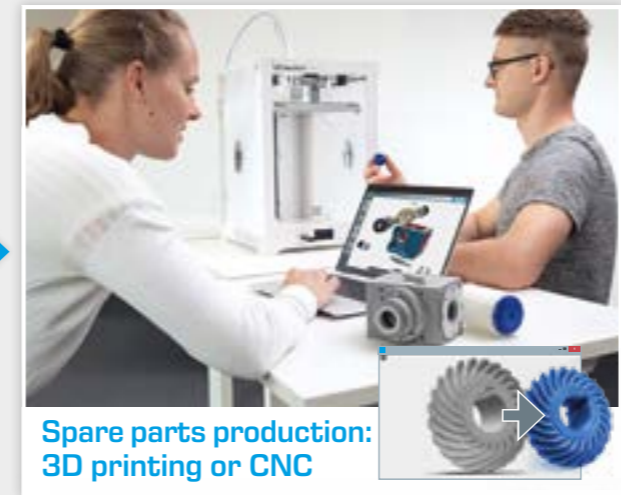

Spare parts production: 3D printing or CNC

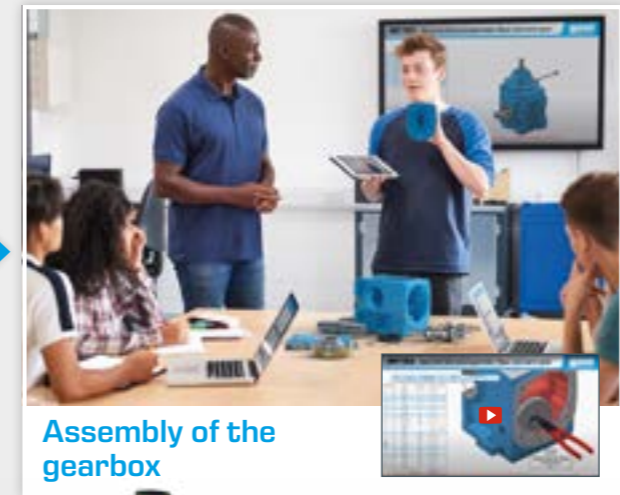

Assembly of the gearbox



Functional test for quality assurance

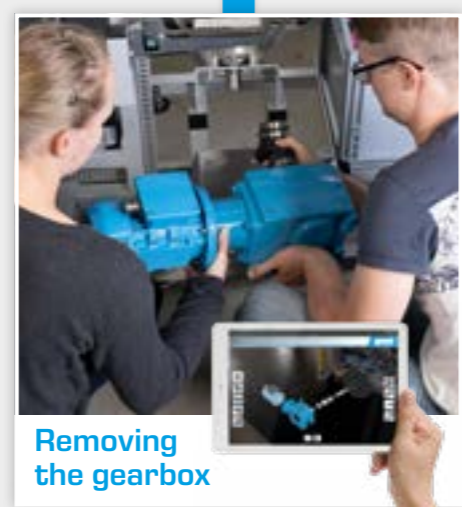

Removing the gearbox

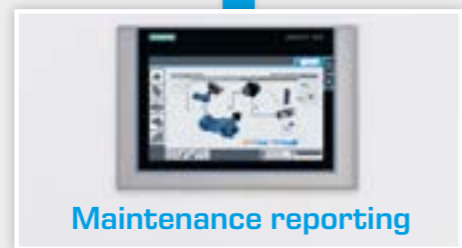

Maintenance reporting



The MT174 Sorting plant is used as the industrial plant



Didactic concept
GUNT-DigiSkills 3
Planning education elements and teaching sequences for a complex learning project

How to achieve the digital transformation to Industry 4.0

Our product programme



Engineering mechanics and engineering design

- statics
- strength of materials
- dynamics
- machine dynamics
- engineering design
- materials testing



Mechatronics

- engineering drawing
- cutaway models
- dimensional metrology
- fasteners and machine parts
- manufacturing engineering
- assembly projects
- maintenance
- machinery diagnosis
- automation and process control engineering



Thermal engineering

- fundamentals of thermodynamics
- heat exchangers
- thermal fluid energy machines
- internal combustion engines
- refrigeration
- HVAC



Fluid mechanics

- physical principles
- steady flow
- transient flow
- flow around bodies
- fluid machinery
- components in piping systems and plant design
- fluid machinery
- hydraulics for civil engineering



Process engineering

- mechanical process engineering
- thermal process engineering
- chemical process engineering
- biological process engineering



Energy & Environment

- Energy**
 - solar energy
 - wind power
 - green hydrogen technology
 - hydropower and ocean energy
 - biomass
 - geothermal energy
 - energy systems
 - energy efficiency in buildings
- Environment**
 - water
 - air
 - soil
 - waste

Index

Keyword	Code (page)
---------	-------------

A	
absorption	CE 400 (66)
activated carbon	CE 581 (52) CE 583 (42) CE 585 (56)
activated sludge process	CE 704 (30) CE 705 (26)
adsorption	CE 540 (68) CE 581 (52) CE 583 (42) CE 585 (56)
air pollution control	CE 235 (64) CE 400 (66) CE 540 (68)
airlift	CE 730 (34)
augmented reality	MT 174 (104)

B	
backwash	CE 579 (22) CE 581 (52) CE 582 (54) CE 585 (56)
ball mill	CE 245 (98)
biofilm	CE 701 (32)
biogas	CE 702 (36)
breakthrough curve	CE 540 (68) CE 582 (54) CE 583 (42)

C	
candle filter	CE 585 (56)
Carman-Kozeny	CE 117 (84)
classifying	MT 174 (104)
colour sorting	MT 174 (104)
comminution	CE 245 (98)
concentration profile	CE 583 (42) CE 701 (32)
conveyor belt	MT 174 (104)
cyclone	CE 225 (88) CE 235 (64) CE 275 (102)

D	
Darcy	CE 117 (84) CE 579 (22)
denitrification	CE 701 (32) CE 704 (30) CE 705 (26)
desorption	CE 400 (66)
differential pressure	CE 117 (84) CE 225 (88) CE 235 (64) CE 275 (102) CE 579 (22) CE 581 (52) CE 582 (54)
differential pressure head	CE 117 (84) CE 579 (22)
disinfection	CE 585 (56)
dissolved air flotation	CE 587 (18) CE 588 (20)
drum screen	MT 174 (104)

E	
extraction	CE 630 (90)

Keyword	Code (page)
---------	-------------

F	
filtration	CE 117 (84) CE 579 (22) CE 581 (52) CE 582 (54)
flocculation	CE 586 (46) CE 587 (18) CE 588 (20)
flotation	CE 587 (18) CE 588 (20)
fluidisation velocity	CE 117 (84) CE 579 (22)
fluidised bed	CE 117 (84) CE 579 (22)

G	
gas flow classification	CE 275 (102)
ground water flow	CE 117 (84) HM 165 (76) HM 167 (80) HM 169 (82)

H	
hydrogen peroxide	CE 584 (48)
hydrogeology	CE 117 (84) HM 141 (78) HM 165 (76) HM 167 (80) HM 169 (82)
hydrograph	HM 141 (78)

I	
ion exchange	CE 300 (45) CE 581 (52) CE 582 (54) CE 585 (56)

L	
lamella separator	CE 586 (46) HM 142 (16)

M	
magnetic separation	CE 280 (100)
maintenance	MT 174 (104)
mass transfer zone	CE 540 (68) CE 583 (42)
membrane separation process	CE 530 (44)
methane	CE 702 (36)
Micheau	CE 579 (22) CE 582 (54)

N	
nitrification	CE 701 (32) CE 704 (30) CE 705 (26)

O	
oxidation	CE 584 (48) CE 585 (56)

Keyword	Code (page)
---------	-------------

P	
packed bed	CE 117 (84)
particle layer	CE 117 (84)
permeability	CE 117 (84)
PLC	CE 530 (44) CE 581 (52) CE 705 (26) CE 585 (56) MT 174 (104)
precipitation	CE 586 (46)
pressure loss	CE 117 (84) CE 225 (88) CE 235 (64) CE 275 (102) CE 579 (22) CE 581 (52) CE 582 (54)

R	
rain	HM 141 (78) HM 165 (76)
rainwater retention basin	HM 141 (78)
reaction kinetics	CE 584 (48)
reactor, stirred	CE 702 (36) CE 704 (30)
retaining wall	HM 169 (82)
reverse osmosis	CE 530 (44)

S	
sand filter	CE 579 (22) CE 581 (52) CE 582 (54)
SBR	CE 704 (30)
secondary clarification	CE 701 (32) CE 702 (36) CE 705 (26)
sedimentation	HM 142 (16) CE 586 (46) CE 704 (30) CE 705 (26)
seepage flow	CE 117 (84) HM 165 (76) HM 167 (80) HM 169 (82)
separation function	CE 235 (64) CE 275 (102)
separation process	CE 280 (100) MT 174 (104)
separation size	CE 235 (64) CE 275 (102)
sequencing batch reactor	CE 704 (30)
sheet pile	HM 169 (82)
soil treatment	CE 225 (88) CE 630 (90)
sorting	CE 280 (100) MT 174 (104)
spiral wound membrane module	CE 530 (44)
storage capacity (of soil)	HM 141 (78) HM 165 (76)
streamlines	HM 169 (82)

T	
touch screen	CE 530 (44) CE 581 (52) CE 585 (56) CE 704 (30) CE 705 (26) MT 174 (104)
trickling filter	CE 701 (32)

Keyword	Code (page)
---------	-------------

U	
UASB	CE 702 (36)
UV light	CE 584 (48) CE 585 (56)

W	
wastewater treatment plant	CE 701 (32) CE 702 (36) CE 704 (30) CE 705 (26)
water treatment (aerobic)	CE 701 (32) CE 704 (30) CE 705 (26) CE 730 (34)
water treatment (anaerobic)	CE 702 (36)
water treatment (biological)	CE 701 (32) CE 702 (36) CE 704 (30) CE 705 (26) CE 730 (34)
water treatment (mechanical)	CE 579 (22) CE 587 (18) CE 588 (20) HM 142 (16)
water treatment (multi-stage)	CE 581 (52) CE 582 (54) CE 585 (56)
water treatment (physical/chemical)	CE 300 (45) CE 530 (44) CE 583 (42) CE 584 (48) CE 586 (46)
well	HM 165 (76) HM 167 (80)

Z	
zigzag sifter	CE 275 (102)

Product overview

CE		
CE 117	Flow through particle layers	084
CE 225	Hydrocyclone	088
CE 235	Gas cyclone	064
CE 245	Ball mill	098
CE 275	Gas flow classification	102
CE 280	Magnetic separation	100
CE 300	Ion exchange	045
CE 400	Gas absorption	066
CE 530	Reverse osmosis	044
CE 540	Adsorptive air drying	068
CE 579	Depth filtration	022
CE 581	Water treatment plant 1	052
CE 582	Water treatment plant 2	054
CE 583	Adsorption	042
CE 584	Advanced oxidation	048
CE 585	Water purification process	056
CE 586	Precipitation and flocculation	046
CE 587	Dissolved air flotation	018
CE 588	Demonstration of dissolved air flotation	020
CE 630	Solid-liquid extraction	090
CE 701	Biofilm process	032
CE 702	Anaerobic water treatment	036
CE 704	SBR process	030
CE 705	Activated sludge process	026
CE 730	Airlift reactor	034

HM		
HM 141	Hydrographs after precipitation	078
HM 142	Separation in sedimentation tanks	016
HM 165	Studies in hydrology	076
HM 167	Ground water flow	080
HM 169	Visualisation of seepage flows	082

MT		
MT 174	Sorting plant	104



Contact

G.U.N.T. Gerätebau GmbH
Hanskampring 15 -17
22885 Barsbüttel
Germany

+49 40 67 08 54 -0
sales@gunt.de
www.gunt.de

GUNT
TECHNOLOGY
LIMITED

GUNT Technology Limited
Unit 3 · Glenmore Business Park
Colebrook Way
Andover, SP10 3GL

t: +44(0) 1264 33 93 56
e: sales@gunt-technology.co.uk
www.gunt-technology.co.uk



Visit our website
www.gunt.de

