

Equipment
for Engineering
Education

Process
engineering



Table of contents

Welcome to GUNT

In this catalogue we present a comprehensive overview of our innovative demonstration and experimental units.

GUNT units are used for:

- education in technical professions
- training and education of technical personnel in trade and industry
- studies in engineering disciplines

Process engineering

	Introduction	004
1	Mechanical process engineering	006
2	Thermal process engineering	084
3	Chemical process engineering	134
4	Biological process engineering	170
5	Pilot plants	202
	Product overview	224

Imprint

© 2023 G.U.N.T. Gerätebau GmbH. Any reuse, storage, duplication and reproduction – even in extracts – is prohibited without written approval. GUNT is a registered trademark. This means GUNT products are protected and subject to copyright.

No liability can be accepted for printing errors. Subject to change without notice.

Image credits: G.U.N.T. Gerätebau GmbH, manufacturers' photos, Shutterstock, 123RF.
Design & typesetting: Profisatz.Graphics, Bianca Buhmann, Hamburg.
Printed on chlorine-free, environmentally friendly paper.

Training in process engineering with GUNT training systems

Core areas of process engineering

Process engineering deals with processes in which substances are changed in terms of their composition or properties. Such processes are used, for example, in the following industries:

- chemical industry
- food industry
- textile industry
- petrochemical industry
- environmental engineering

Systematic training of prospective engineers and skilled workers is essential in order to understand the complex interrelationships in process engineering. Historically, the basic processes of process engineering have been divided into the four core areas below. This classification is based on the type of action involved in the respective basic process.

Mechanical process engineering	Mechanical process engineering involves the changes in material properties (e.g. particle size), and composition (concentration), due to mechanical effects.
Thermal process engineering	Thermal process engineering focuses on thermal separation processes. In mixtures made up of at least two components, heat and material transfer processes are used to selectively change the composition (concentration) of the mixture.
Chemical process engineering	The focus of chemical process engineering is not to change substance properties or the composition of a substance. The central subject of chemical process engineering is the creation of a new substance type through chemical reaction.
Biological process engineering	In biological process engineering, substances are converted by means of biologically active organisms, such as bacteria, fungi, algae, cells and enzymes. The aim of biological process engineering is to provide optimum conditions for these organisms.

Part of the Energy & Environment product area GUNT software, digital data acquisition, experiment evaluation



Structure of the catalogue

The structure of this catalogue follows the classical division of process engineering into the four core areas. The individual basic processes are based on mechanical, thermal, chemical and biological laws or empirical knowledge. In addition, you will find various pilot-scale process engineering systems in chapter 5.

A basic process is the smallest theoretically defined unit of an overall process. The restriction to these small units makes sense from a research perspective and also a didactic perspective as complex tasks already have to be solved at the unit operations level due to the several phases (solid, liquid, gaseous) and substances involved.

	Mechanical process engineering	Separation methods
		▶ Classifying
		▶ Sorting
		▶ Separation in a gravity field
		▶ Separation in a centrifugal force field
		▶ Filtration
		Comminution
		Mixing
		Agglomeration
		Storage and flow of bulk solids
	Thermal process engineering	Fluidised beds and pneumatic transport
		Drying
		Evaporation
		Distillation and rectification
		Absorption
		Adsorption
		Crystallisation
		Membrane separation processes
		Extraction
		Mass transfer
	Chemical process engineering	Thermal activation
		Catalytic activation
		Photochemical activation
	Biological process engineering	Aerobic processes
		Anaerobic processes
	Pilot plants	Pilot-scale process plants

Mechanical process engineering

Learning unit operations of mechanical process engineering by experimentation

GUNT offers a complete range of units to learn the unit operations involved in mechanical process engineering.

Please note:

Your laboratory facilities must be suitable for operation of the units. Depending on the specific process and the materials used, sealed floors, drains, water and/or compressed air connections, ventilators, special foundations, secure material storage facilities etc. may be required.

To evaluate many of the experiments you will need professional analysis systems beyond the scope of the training system packages supplied by GUNT.

Please contact us. We will be happy to give advise.

Introduction

Overview The GUNT learning concepts of mechanical process engineering	008
--	-----

Separation methods: classifying and sorting

Basic knowledge Classifying	010
------------------------------------	-----

Basic knowledge Sorting	011
--------------------------------	-----

Overview CE 275 Gas flow classification	012
--	-----

CE 275 Gas flow classification	014
---------------------------------------	-----

CE 264 Screening machine	016
---------------------------------	-----

Overview MT174 Sorting plant	017
-------------------------------------	-----

CE 280 Magnetic separation	018
-----------------------------------	-----

Separation methods: separation in a gravity field

Basic knowledge Sedimentation	020
--------------------------------------	-----

Basic knowledge Flotation	021
----------------------------------	-----

CE 115 Fundamentals of sedimentation	023
---	-----

Overview HM142 Separation in sedimentation tanks	024
---	-----

HM 142 Separation in sedimentation tanks	026
---	-----

Overview CE587 Dissolved air flotation	028
---	-----

CE 587 Dissolved air flotation	030
---------------------------------------	-----

CE 588 Demonstration of dissolved air flotation	032
--	-----

Separation methods: separation in a centrifugal force field

Basic knowledge Separation in a centrifugal force field	035
--	-----

CE 282 Disc centrifuge	036
-------------------------------	-----

CE 235 Gas cyclone	038
---------------------------	-----

CE 225 Hydrocyclone	040
----------------------------	-----

Separation methods: filtration

Basic knowledge Filtration	042
-----------------------------------	-----

CE 116 Cake and depth filtration	043
---	-----

CE 117 Flow through particle layers	044
--	-----

CE 287 Plate and frame filter press	046
--	-----

CE 283 Drum cell filter	048
--------------------------------	-----

CE 284 Nutsche vacuum filter	050
-------------------------------------	-----

CE 286 Nutsche pressure filter	051
---------------------------------------	-----

CE 285 Suspension production unit	052
--	-----

Overview CE579 Depth filtration	054
--	-----

CE 579 Depth filtration	056
--------------------------------	-----

Comminution

Basic knowledge Comminution	058
------------------------------------	-----

CE 245 Ball mill	059
-------------------------	-----

Mixing and agglomeration

Basic knowledge Mixing	060
-------------------------------	-----

Basic knowledge Agglomeration	061
--------------------------------------	-----

CE 320 Stirring	062
------------------------	-----

Overview CE322 Rheology and mixing quality in a stirred tank	064
---	-----

CE322 Rheology and mixing quality in a stirred tank	066
--	-----

CE 255 Rolling agglomeration	068
-------------------------------------	-----

Storage and flow of bulk solids

Basic knowledge Storage and flow of bulk solids	070
--	-----

CE 210 Flow of bulk solids from silos	072
--	-----

CE 200 Flow properties of bulk solids	074
--	-----

Fluidised beds and pneumatic transport

Basic knowledge Fluidised beds	076
---------------------------------------	-----

Basic knowledge Pneumatic transport	077
--	-----

CE 220 Fluidised bed formation	078
---------------------------------------	-----

CE222 Comparison of fluidised beds	080
---	-----

CE 250 Pneumatic transport	082
-----------------------------------	-----

The GUNT learning concepts of mechanical process engineering

What does mechanical process engineering involve?

Process engineering is the engineering science of material transformation.

Mechanical process engineering involves the changes in material properties (e.g. particle size), and composition (concentration), due to mechanical effects.

The mechanical effects are forces acting on the materials. These forces may include compression forces, friction forces, impulses, or forces triggered by flow resistances.

The material systems with which mechanical process engineering concerns itself are termed dispersed systems. They consist at least of a dispersed phase and a continuous phase. The dispersed phase usually comprises large numbers of individual particles which are finely distributed (dispersed) in the continuous phase. The dispersed phase largely involves solids, however, both phases may also be liquid or gaseous. Examples of dispersed systems are bulk solids such as sand, ore-bearing rock, suspensions, emulsions and dusts.

How can the unit operations in mechanical process engineering be classified?

Unit operations in mechanical process engineering		
Involving change in particle size	Without change in particle size	
Comminution	Separation methods	Mixing
Agglomeration	Storage and flow of bulk solids	Fluidised beds and pneumatic transport

The processes can essentially be divided into two principal categories. In the comminution and agglomeration (particle size enlargement) processes, the size of solid particles is purposely altered. In the separation, mixing, storage and transport of bulk solids, the particle size usually remains unchanged. The separation methods in many cases involve the separation of solid, dispersed phases from fluids and the division of solid compounds into fractions with different particle properties.

In fluidised beds, mixing, separation or agglomeration processes may occur, depending on the application.

Prof. Gorzitzke advised us when we were setting up this range and contributed his many years of experience in the area of mechanical process engineering.



Prof. Dr. Wolfgang Gorzitzke (Anhalt University of Applied Sciences), our technical advisor on mechanical process engineering

Our training systems for mechanical process engineering

Comminution		CE 245	Ball mill
Agglomeration		CE 255	Rolling agglomeration
Separation methods	Classifying	CE 275	Gas flow classification
		CE 264	Screening machine
	Sorting	CE 280	Magnetic separation
	Separation in a gravity field	CE 115	Fundamentals of sedimentation
		HM142	Separation in sedimentation tanks
	CE 587	Dissolved air flotation	
	CE 588	Demonstration of dissolved air flotation	
	Separation in a centrifugal force field	CE 282	Disc centrifuge
		CE 235	Gas cyclone
		CE 225	Hydrocyclone
	Filtration	CE 116	Cake and depth filtration
		CE 117	Flow through particle layers
		CE 287	Plate and frame filter press
		CE 283	Drum cell filter
		CE 284	Nutsche vacuum filter
		CE 286	Nutsche pressure filter
		CE 579	Depth filtration
Mixing		CE 320	Stirring
		CE 322	Rheology and mixing quality in a stirred tank
Storage and flow of bulk solids		CE 210	Flow of bulk solids from silos
		CE 200	Flow properties of bulk solids
Fluidised beds and pneumatic transport		CE 220	Fluidised bed formation
		CE 222	Comparison of fluidised beds
		CE 250	Pneumatic transport

Basic knowledge Classifying

Classification is a mechanical separation method for solid compounds. It utilises either, the geometric features (size) or the settling velocities of the individual particles for the separation process. Accordingly, a distinction is made between sieve and flow classification.

Ideally, a classifier separates a feed with differing particle sizes into coarse and fine materials. The coarse material would then contain all the particles larger than a specific separation size, and the fine material all the particles smaller than that size.

The simplest example of a classifier is a sieve. In this case the separation size is determined by the sieve mesh width. With the sieve layout shown, it is possible to sort a feed into several particle size classes.

A practical example of the application of such a layout (though with larger sieve mesh widths) is the separation of ballast, gravel and sand from quarried material.

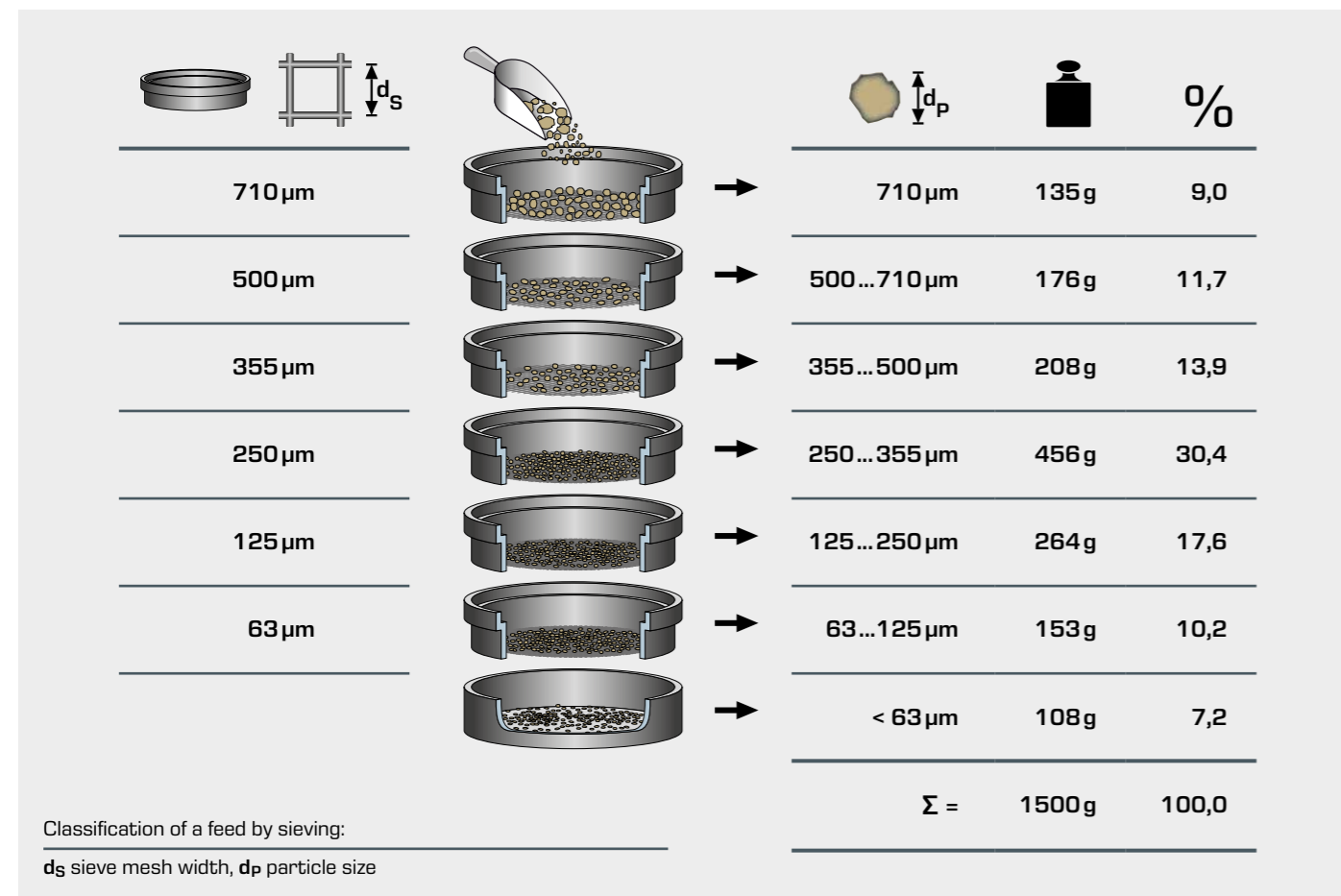

In **sieving**, each particle is compared to a sieve mesh according to its size and shape. Irregularly shaped particles may be hindered in passing through the sieve mesh depending on their positioning or orientation. The particles may also obstruct each other, or adhere to each other. It is therefore necessary to provide each particle with the opportunity to pass through the mesh multiple times. This can be accomplished, for example, by vibrating, tumbling, projectile or horizontal movements of the sieves.

Flow classification may take place in gases (air) or liquids (water).

In **wet flow classification**, the differing settling velocities of particles in a liquid flow are used as a separating criterion. The settling velocity depends on the size, density and shape of the individual particles and the resultant forces due to flow resistance and weight.

In **gas flow classification (wind sifting)**, an airflow is used for classification instead of a liquid. The underlying laws of the separation principle applying to this are identical to those of wet flow classification. Wind sifters are used, for example, in the cleaning of corn, to separate off toxic components such as secale cornutum (ergot).

Basic knowledge Sorting

Sorting is a mechanical separation process in which a solid compound containing different material characteristics is divided into fractions with the same material characteristics. In sorting, properties such as density, colour, shape, wettability or magnetisability are utilised.

Where **density** is applied as the separation criterion, a **float-sink sort** is suitable. A solid compound is placed in a liquid. The particles in the compound which are of lower density than the liquid float on the surface, while higher-density particles sink. One application of this is in coal preparation, in which the coal is separated from the surrounding strata.

In **magnetic separation**, a solid compound is separated into its constituent components based on the **magnetic** properties of those components. Magnetic separators are used, for example, in coal and ore preparation.

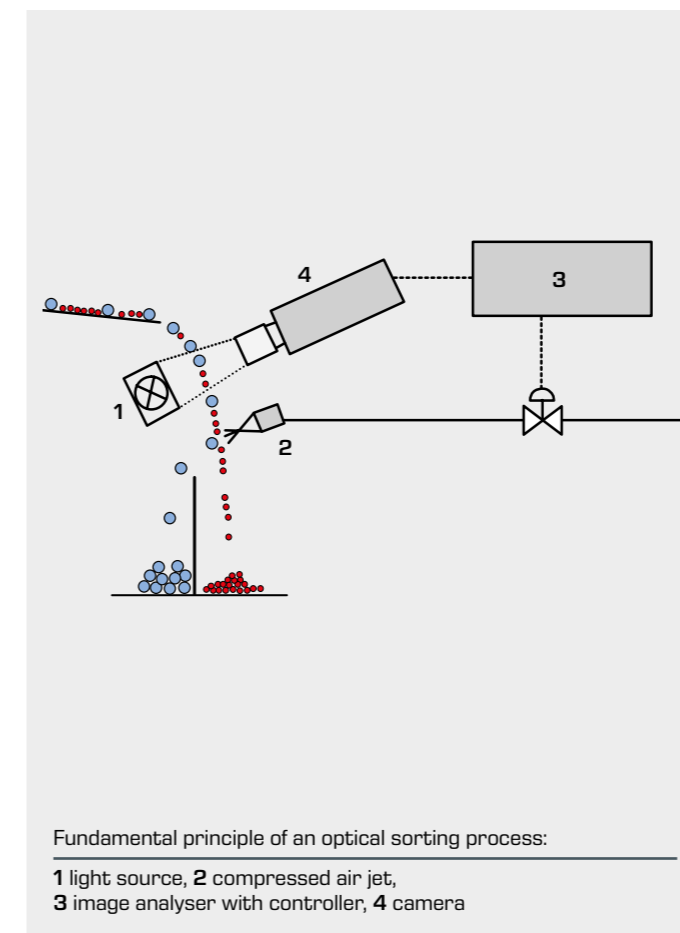

The **shape and colour** of specific particles can be recorded from a solid compound using high-resolution cameras. Using a special electronic analysis technique, the detected particles can be separated out of the compound by an airflow. **Optical sorting methods** are used in the recycling of glass.

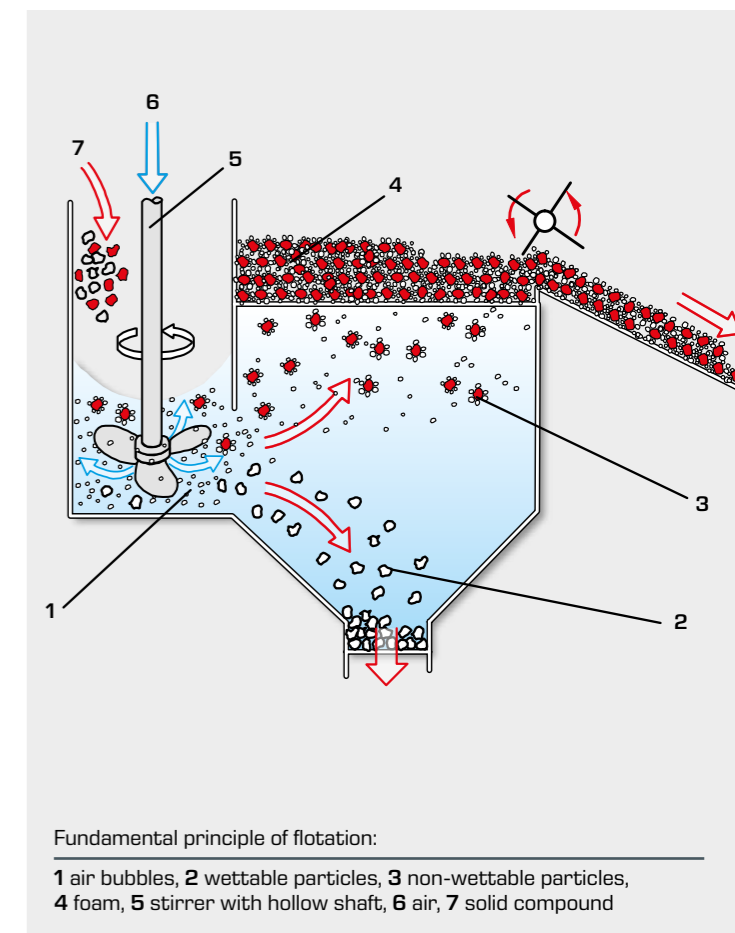

The **wettability** of specific materials with water in **flotation**, sorts fine-grained solids. The solid compound to be separated is placed in a container with water. Air bubbles are introduced into the water. The bubbles adhere to the solid particles which are not easily wettable with water. Those particles are carried with the bubbles to the surface of the water, where they form a solid-bearing foam which can be scooped off. No bubbles adhere to the water-wettable particles. They remain in suspension or sink to the bottom. Flotation is the most frequently applied method of sorting particles < 0.5 mm.

Overview

CE 275 Gas flow classification

Gas flow classification with zigzag sifter: a mechanical separation process

Gas flow classification is a mechanical separation process from the field of conventional process engineering. In waste management, this process is used for the separation of various wastes, for example, to separate dust, sand or non-reusable materials from reusable materials. This is mainly achieved by the use of zigzag sifters.

This teaching unit is perfectly suited to teaching the theoretical fundamentals of this process, clearly and practically. The main element of CE 275 is a 20-stage zigzag sifter, which is equipped with a transparent cover. This allows you to observe the separation process in the zigzag channel over the entire height.

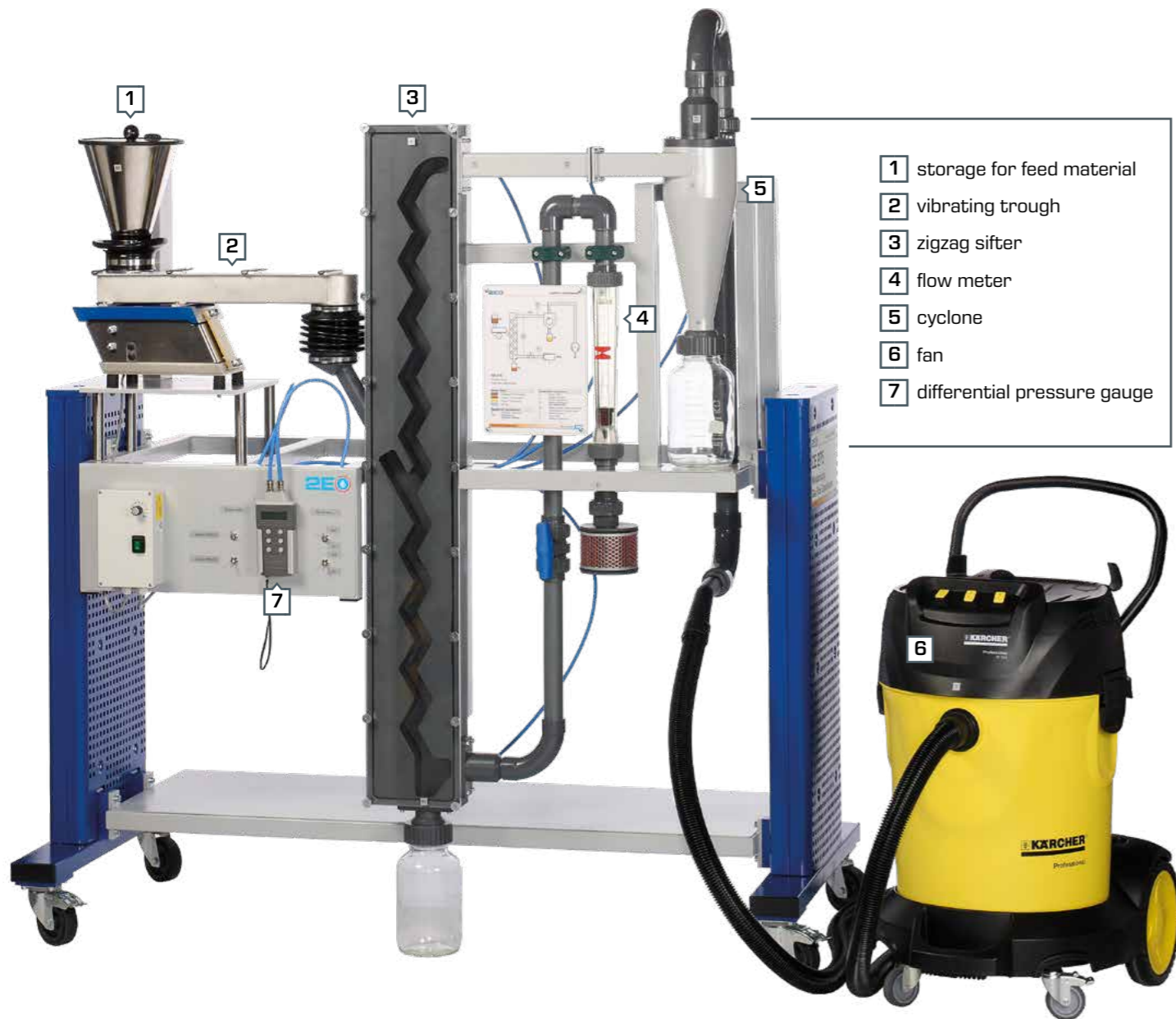

- 1 storage for feed material
- 2 vibrating trough
- 3 zigzag sifter
- 4 flow meter
- 5 cyclone
- 6 fan
- 7 differential pressure gauge

Principle of operation

The waste mixture to be separated (feed material) is conveyed evenly into the zigzag sifter by a vibrating trough. The fan generates the upwardly directed airflow necessary for separation through the zigzag channel. You can adjust the mass flow rate of the feed material and the volumetric flow rate of the air. The fraction of the feed material transported along with the air is then separated in a cyclone. This allows a closed circuit for the air flow. The zigzag sifter and cyclone are each equipped with differential pressure measurement.



CE 275 during a trial run:
The vibrating trough evenly conveys the mixture of spelt husks and cherry stones to be separated from to the zigzag sifter.



In the zigzag channel, the separation of the mixture can clearly be observed.

This device has been developed by our experienced engineers in collaboration with the Institute of Mechanical Process Engineering at the Anhalt University of Applied Sciences (Germany).

Hochschule Anhalt
Anhalt University of Applied Sciences

Recommended accessory



We recommend our CE 264 Screening Machine for analysis of the experiments.

Learning objectives

- familiarisation with the basic principle of gas flow classification
 - influence of the mass flow rate and the airflow rate on
 - ▶ fine material fraction
 - ▶ quality of separation
 - ▶ sifter pressure loss
 - ▶ cyclone pressure loss
 - ▶ fraction balance
 - ▶ separation function
 - ▶ separation size
 - ▶ sharpness of separation
- } with CE 264

About the product:



CE 275

Gas flow classification



2E

Description

- gas flow classification with a zigzag sifter
- transparent duct to observe the separation process
- practical experiments on a laboratory scale

Zigzag sifters permit classification of solid compounds. The solid compound being separated is charged into the feed hopper. The compound is fed into the zigzag duct of the sifter at mid-height by way of a vibrating trough. An air flow flows upwards through the vertical duct. Depending on the geometry and density of the particles, they are carried along by the air or drop down due to gravity. At every bend in the duct the solid compound passes through the air flow and falls onto the opposite wall of the sifter. This corresponds to one sifting stage. Owing to the flow conditions, a vortex wake is formed between two bends of the zigzag duct. It ensures that the solid matter moves roughly perpendicular to the air flow. In this way, a transverse sift takes place at every bend.

Sequencing of large numbers of such stages results in very fine separation. CE 275 features a 20-stage zigzag duct. Transparent material provides optimum observation of the processes in the duct.

A fan generates the air flow. The volumetric air flow rate and the solid mass flow are adjustable. The fine material transported upwards with the air flow is separated by a cyclone. Pressure measurement points at the relevant positions in the trainer enable the pressure loss to be determined.

Activated carbon in different particle sizes is recommended for use as the feed material. For particle size analyses of the feed and of the coarse and fine material, a balance and a screening machine (CE 264) are recommended.

Learning objectives/experiments

- learning the fundamental principle of wind sifting (gas flow classification)
- sorting
 - ▶ coarse material fraction
 - ▶ fine material fraction
- dependent on solid mass flow rate and volumetric air flow rate
- classifying (with CE 264)
 - ▶ fraction balance
 - ▶ separation function
 - ▶ separation size
 - ▶ sharpness of separation
- dependent on solid mass flow rate and volumetric air flow rate
- pressure losses of
 - ▶ sifter
 - ▶ cyclone dependent on solid mass flow rate and volumetric air flow rate

CE 275

Gas flow classification

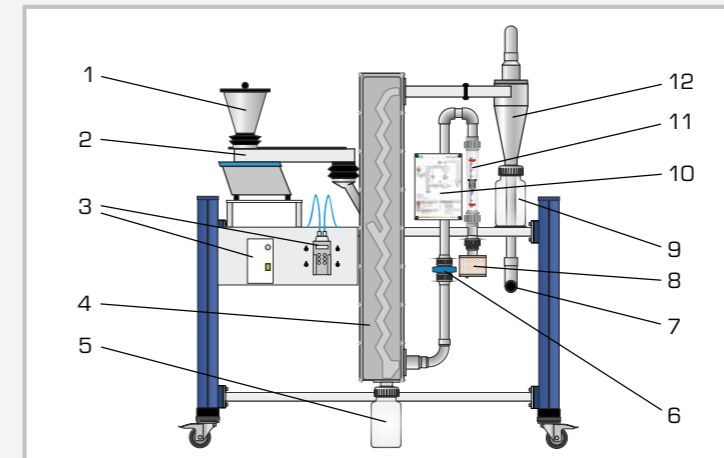

1 feed material tank, 2 vibrating trough, 3 displays and controls, 4 sifter, 5 coarse material tank, 6 valve, 7 connection for fan, 8 filter, 9 fine material tank, 10 process schematic, 11 flow meter, 12 cyclone

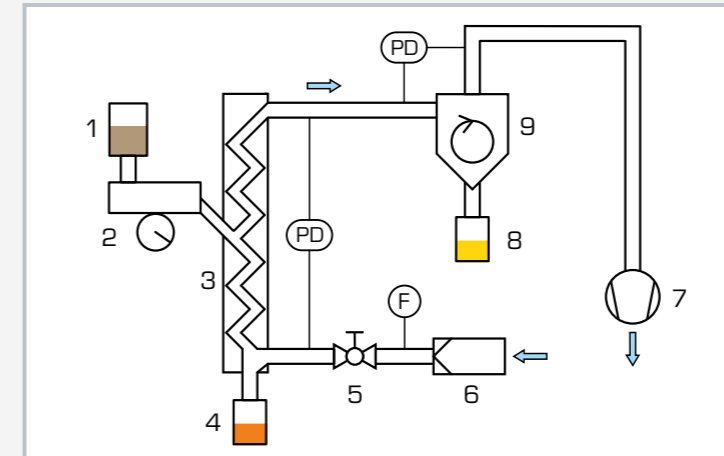

1 feed material tank, 2 vibrating trough, 3 sifter, 4 coarse material tank, 5 valve, 6 filter, 7 fan, 8 fine material tank, 9 cyclone; F volumetric flow rate, PD differential pressure

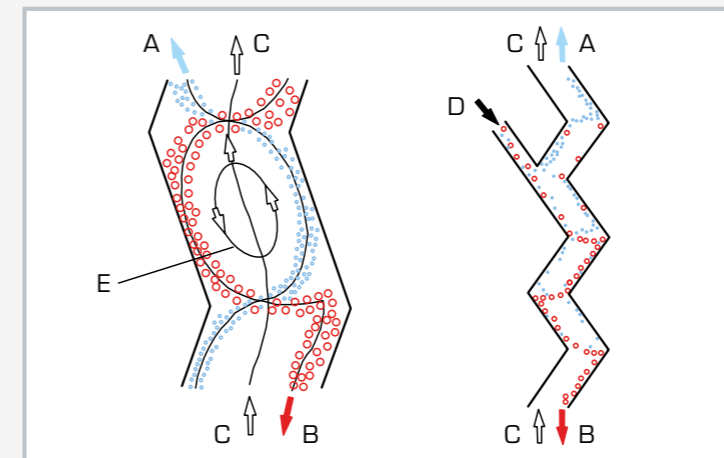

Fundamental principle of zigzag wind sifting: A fine material, B coarse material, C air flow, D feed material, E vortex wake

Specification

- [1] zigzag sifter to separate solid compounds
- [2] feed hopper with vibrating trough for feed of solid compound into sifter
- [3] dosage of feed material by way of distance of hopper outlet from vibrating trough and frequency of vibrating trough
- [4] separation of solid compound into coarse and fine material with air flow in 20-stage zigzag duct
- [5] air flow generation by fan; adjustment by valve
- [6] separation of fine material from air flow by gas cyclone with tangential inlet
- [7] 3 tanks for feed material and coarse and fine materials
- [8] recording of volumetric air flow rate and differential pressure through sifter and cyclone

Technical data

Vibrating trough

- mass flow: max. 10kg/h
- vibration frequency: max. 3000min⁻¹

Zigzag sifter

- height: approx. 1500mm
- cross-sectional area: 40x50mm

Cyclone

- height: approx. 550mm
- diameter: 150mm

Fan

- volumetric flow rate: max. 600m³/h
- power consumption: approx. 3600W

Tanks

- feed hopper: 3L
- coarse material: 2L
- fine material: 2L

Measuring ranges

- differential pressure: 2x 0...100mbar
- volumetric flow rate: 10...100m³/h

230V, 50Hz, 1 phase

LxWxH: 1660x790x1930mm (trainer)

Weight: approx. 180kg (trainer)

LxWxH: 660x510x880mm (fan)

Weight: approx. 30kg (fan)

Scope of delivery

- 1 trainer
- 1 fan
- 2 packing units of feed material
- 1 set of accessories
- 1 set of instructional material

CE 264

Screening machine



Learning objectives/experiments

- determination of particle size distributions

Specification

- [1] screening machine for particle size analysis as accessory for CE 245 and CE 275
- [2] screening duration and vibration height adjustable
- [3] 11 screens with different mesh widths
- [4] scales for determining the mass fraction of the separated classes

Technical data

Ø of the screens: 200mm each
Height of the screens: 50mm each

Screening machine

- screening duration: 0...60min
- vibration height: 0...3mm
- mesh width of the screens
 - ▶ 45µm
 - ▶ 63µm
 - ▶ 125µm
 - ▶ 250µm
 - ▶ 500µm
 - ▶ 710µm
 - ▶ 1000µm
 - ▶ 1250µm
 - ▶ 1600µm
 - ▶ 2000µm
 - ▶ 4000µm

Scales

- max. weight: 2200g
- resolution: 10mg

230V, 50Hz, 1 phase
230V, 60Hz, 1 phase
120V, 60Hz, 1 phase
UL/CSA optional
LxWxH: 400x400x800mm (screening machine)
LxWxH: 200x270x100mm (balance)
Weight: approx. 30kg

Scope of delivery

- 1 screening machine
- 1 set of screens
- 1 balance
- 1 manual

Description

■ professional analyser for CE 245 and CE 275

The screening machine enables users to separate a mixture of solids into several classes of particle sizes. In the screening process, each particle is compared with a screen mesh in terms of size and shape. Depending on their position, particles with an irregular shape may not be able to pass through the mesh. As the screening machine is vibrating, each particle has the possibility to pass through the meshes several times. First the coarser particles are separated in the upper area. The mesh width decreases towards the bottom.

To be able to adapt the machine to the respective requirements, several screens with various mesh widths are included in the scope of delivery. Scales enable the user to determine the masses of the separated classes in order to determine the particle size distribution.

Overview

MT174 Sorting plant

The MT174 Sorting plant is modelled on a typical separation process from waste management and includes classification by means of a drum screen and colour sorting.

Maintenance and servicing are prerequisites for the reliable operation of a sorting plant. Which is why it is possible to perform maintenance work on the sorting plant for training purposes. If the plant is operated in training mode, the PLC independently generates time- and sensor-based messages for maintenance work to be carried out. An augmented reality interface is available for mobile devices to visualise the maintenance work.

- laboratory scale sorting plant with standard industrial components
- separation into 3 size fractions with drum screen
- colour sorting into 3 fractions
- control of the experimental plant using a PLC, operated by touch screen
- augmented reality for visualisation of maintenance work

The plant is controlled by a modern PLC with touch screen. For the sake of transparency, a separate user interface is provided for each functional group. All parameters relevant to the separation process can be configured using the PLC. These include, for example, the speed and inclination of the drum screen. It is also possible to define the colours of the particles to be sorted in the PLC.

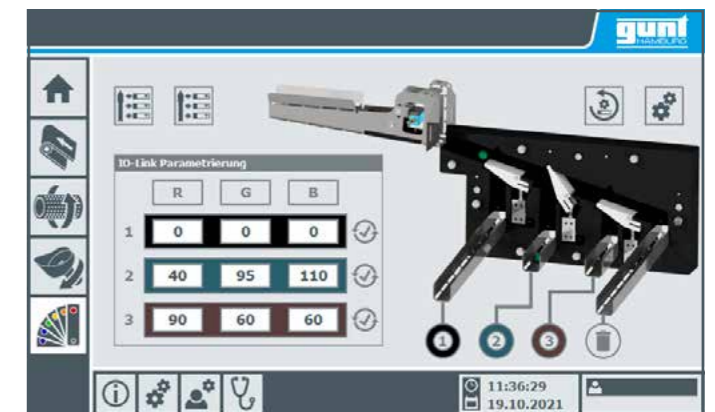

Screenshot from the PLC
(colour sorting)

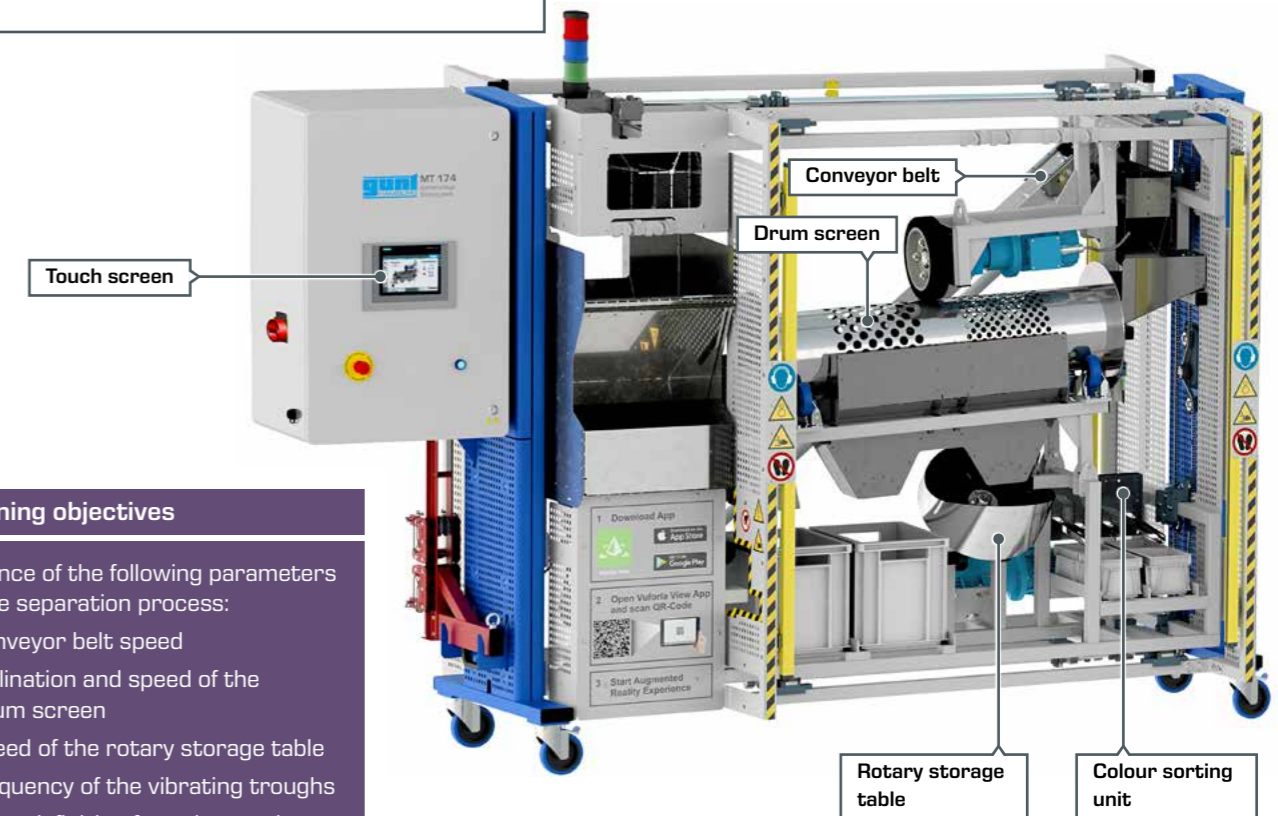

Learning objectives

- influence of the following parameters on the separation process:
 - ▶ conveyor belt speed
 - ▶ inclination and speed of the drum screen
 - ▶ speed of the rotary storage table
 - ▶ frequency of the vibrating troughs
 - ▶ color definition for color sorting
- maintenance work on an industrial plant (supported by augmented reality)

About the product:



CE 280

Magnetic separation



2E

Description

- sorting with a drum-type magnetic separator
- feed through vibrating trough with adjustable throw
- practical experiments on a laboratory scale

During sorting, a solid compound is separated according to its material characteristics.

Magnetic separation is a method of sorting which utilises the magnetisability of components of a solid compound. Magnetic separators are often used in coal and ore preparation.

In the CE 280, the solid compound to be separated is charged into the feed hopper. A vibrating trough conveys the compound onto a rotating, non-magnetic drum. Its speed can be adjusted by way of a potentiometer. In one area of the drum there is a fixed permanent magnet.

Non-magnetisable components drop into a collector tank due to gravity. Magnetisable components adhere to the drum in the area of the magnet, are carried along and drop into a different tank as soon as they are beyond the magnetic zone. The mass flow of the feed material can be adjusted by way of the distance of the hopper outlet from the vibrating trough and by the throw and frequency of the trough. A mixture of sand and small steel items, such as hexagon nuts, is recommended and supplied for use as the feed material.

Learning objectives/experiments

- familiarisation with the fundamental principle and the method of operation of a drum-type magnetic separator
- efficiency of separation process dependent on
 - ▶ mass flow of feed material
 - ▶ mixing ratio of feed material
 - ▶ type of feed material
 - ▶ drum rotation speed

CE 280

Magnetic separation



1 feed hopper with height adjuster, 2 vibrating trough controls, 3 magnetic separator controls, 4 solid compound tank, 5 magnetic materials tank, 6 non-magnetic materials tank, 7 magnetic separator, 8 vibrating trough

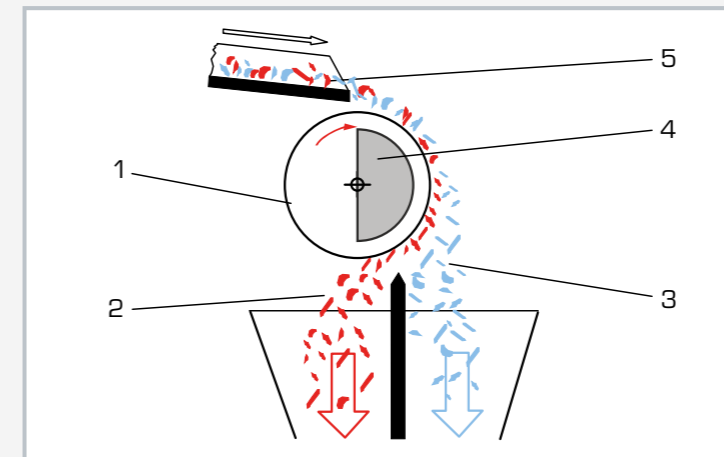

Fundamental principle of drum-type magnetic separators: 1 rotating drum (non-magnetic), 2 magnetisable components, 3 non-magnetisable components, 4 permanent magnet, 5 feed material

Specification

- [1] drum-type magnetic separator for separation of magnetisable components from a solid compound
- [2] separation by a fixed permanent magnet in an area of a rotating, non-magnetic drum
- [3] feed hopper with vibrating trough for feed of solid compound to drum
- [4] dosage of feed material by way of distance of hopper outlet from vibrating trough, throw and frequency of vibrating trough
- [5] drum rotation speed adjustable by electric motor with potentiometer
- [6] 2 steel tanks for separated fractions and 1 tank for solid compound
- [7] feed material: sand and hexagon nuts

Technical data

Feed hopper capacity: 25L

Vibrating trough

- throw: 0,2...1,5mm
- vibration frequency: 50Hz or 100Hz

Drum

- Ø 220mm
- length: 300mm
- magnetic field range: 180°
- speed: 0...30min⁻¹

Motor

- power consumption: 250W

Max. particle size

- non-magnetic: 20mm
- magnetic: 20mm

Tanks

- 2x 15L
- 1x 20L

230V, 50Hz, 1 phase

230V, 60Hz, 1 phase; 120V, 60Hz, 1 phase

UL/CSA optional

LxWxH: 1500x700x1700mm

Weight: approx. 175kg

Scope of delivery

- 1 trainer
- 1 shovel
- 1 packing unit of sand
- 500 nuts
- 1 set of instructional material

Basic knowledge Sedimentation

Mechanical process engineering in many cases utilises gravity to separate different phases. Gravity can be used to separate a solid phase off from a fluid. When solid particles are suspended in a fluid, gravity causes them to sink. For this to happen, the density of the solid must be greater than that of the fluid. The process is termed sedimentation. Fluid is the umbrella term for gases and liquids. It is used because most physical laws apply equally to both.

In terms of the **separation of solids from gases** the phrase "dust separation" is also used. The solid phase may, on the one hand, be a usable material, on the other hand, it may be an unwanted material (gas purification). In gravity separators the gas flow is routed at slower velocity through a separator channel. On their way, the particles sink and are collected.

In practice the **separation of solid/liquid mixtures** (suspensions) takes place in sedimentation tanks through which the suspension continuously flows. The shape of the base may be rectangular or circular. In rectangular tanks the suspension flows in on one side and flows out over the rim on the opposite side. On the way, the solid particles sink to the bottom of the tank. The tank floor is positioned at an angle to aid discharge of the solid material. There are also devices by which the settled solid (sludge) can be cleared from the tank bottom. Sedimentation tanks are mostly used in water treatment.

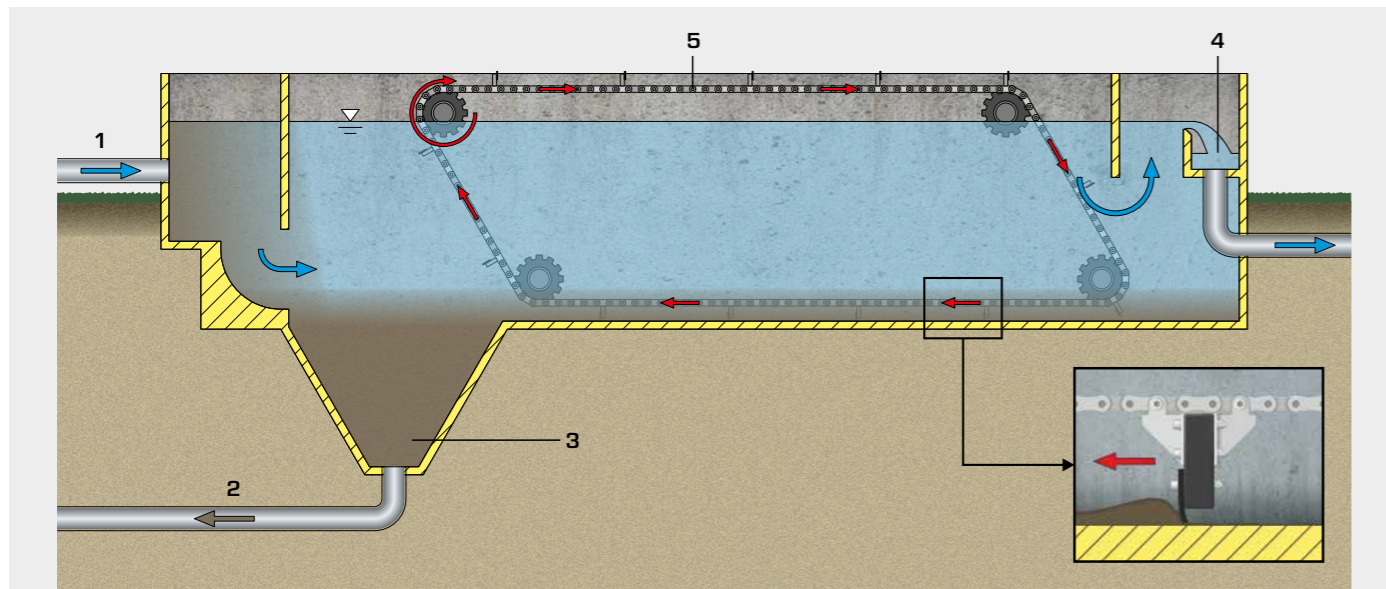

Sedimentation tank:

1 wastewater inlet, 2 sludge extractor, 3 sludge hopper, 4 clean water overflow, 5 sludge scraper

The **settling velocity** of the particles is the key variable in the design of sedimentation tanks and separator channels. It is directly related to the particle size, the particle shape (flow resistance) and the difference in density between the fluid and solid. If the particles in a suspension are very fine, or if the difference in density between the fluid and solid is slight, the settling velocity is very low. A technically useful separation by

means of sedimentation is then not possible. Another variable influencing the settling velocity in liquids is the concentration of solid particles. At high concentrations, sedimentation is hindered. As the concentration increases, the so-called cluster settling velocity becomes less than the velocity of the single particles.

Basic knowledge Flotation

Suspended solids with a density close to or less than that of water can't be removed by sedimentation. Such solids would sediment only very slowly or would remain suspended. The aim of flotation is to increase the buoyancy of the solids. This is done by forming small gas bubbles that attach to the solids. This makes them rise to the surface of the water where they can be skimmed off. It is required that the solids should be hydrophobic. That means that they are more wettable with air than with water. The separated solids are termed float. The key factor

influencing flotation is the size of the gas bubbles. The smaller they are the less will be their rate of rise. This is compensated by larger numbers of small gas bubbles attaching to the solids than large bubbles.

The main process used in water treatment is **dissolved air flotation**. Another flotation variant is electro-flotation. The two processes differ primarily in the way the gas bubbles are produced.

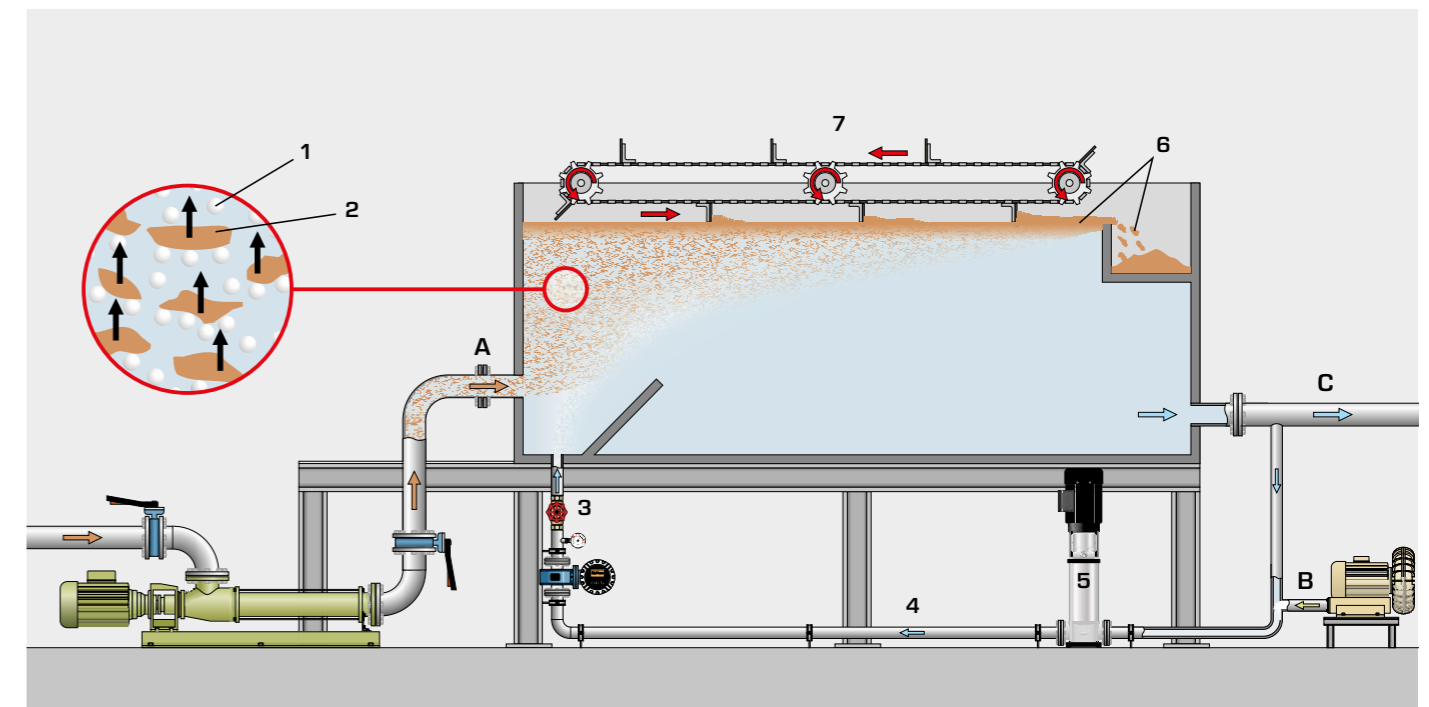

Fundamental principle of dissolved air flotation:

1 air bubbles, 2 solids, 3 relief valve, 4 recycle water, 5 pump, 6 float, 7 scraper;
A raw water, B compressed air, C treated water

Dissolved air flotation

Dissolved air flotation uses the fact that the solubility of air in water increases as the pressure rises at constant temperature. Some of the treated water is saturated with air under pressure (recycle water). The recycle water is then injected into the flotation tank through a special valve that causes an instantaneous reduction in pressure (relief valve). The sudden relief to atmospheric pressure

causes the dissolved air to precipitate as a cloud of small bubbles. A scraper clears the float from the surface of the water. To improve the performance of the process, coagulants and flocculants may be added to the raw water. This helps to optimise the size of the solids so that more air bubbles can be attached to the solids.

Application examples

Industrial water treatment

- paper industry
- food industry
- oil refineries
- plastics industry

Domestic water treatment

- secondary clarification, if the activated sludge sediments very slow
- supplementing or replacing primary clarification



First-rate handbooks



GUNT's policy is simple: high quality hardware and clearly developed instructional material ensure successful teaching and learning about an experimental unit.

The core of this material are detailed reference experiments that we have carried out. The description of the experiment contains the actual experimental setup right through to the interpretation of the results and findings. A group of experienced engineers develops and maintains the instructional material.

Nevertheless, we are here to help should any questions remain unanswered, either by phone or – if necessary – on site.

CE 115 Fundamentals of sedimentation



Description

■ separation of suspensions by sedimentation

Sedimentation is often used to clarify suspensions. In the process, the solid particles move downwards in a liquid owing to their density.

Using CE 115, the sedimentation processes in different suspensions can be investigated and compared. Five transparent cylindrical tanks are provided for the purpose. The suspensions are prepared in measuring cups, poured into the removable tanks, and mixed by shaking. The tanks are then mounted vertically on the experimental unit. To aid observation of the sedimentation process, the tanks are backlit.

Learning objectives/experiments

- determination and comparison of the settling velocities of solids in suspensions dependent on the solid density and concentration and the liquid density and viscosity
- influence of coagulants on the settling velocity

Specification

- [1] experiments in the fundamentals of sedimentation
- [2] 5 transparent tanks with scale for comparison of the settling velocities of solids in various suspensions
- [3] tanks removable for filling, mixing and cleaning
- [4] tanks backlit by fluorescent tubes to aid observation
- [5] 3 measuring cups for preparation of suspensions
- [6] pycnometer to determine the density of the liquids and solids
- [7] stopwatch to record the sedimentation time
- [8] recommended accessories: balance, coagulant

Technical data

Tanks

- length: 1000mm
 - inside diameter: 42mm
 - scale division: 1mm
 - material: PMMA
- #### Fluorescent tubes
- power: 6x 18W
- #### Measuring cups
- capacity: 2000ml
 - scale division: 50ml
- #### Stopwatch
- resolution: 1/100sec

230V, 50Hz, 1 phase
230V, 60Hz, 1 phase
120V, 60Hz, 1 phase
UL/CSA optional
LxWxH: 750x460x1160mm
Weight: approx. 53kg

Required for operation

Coagulant (recommendation)

Scope of delivery

- 1 experimental unit
- 3 measuring cups
- 1 stopwatch
- 1 pycnometer
- 1 set of instructional material

Overview

HM 142 Separation in sedimentation tanks

Sedimentation is the easiest way to separate solid particles from a liquid phase. Therefore this process is very common in water treatment. This device can be used to clearly teach the basics of this separation process. The main focus is on determining the maximum possible hydraulic surface loading.

We have placed great importance on visual observation of the sedimentation process. Therefore mainly transparent materials are used. Furthermore, the sedimentation tank is fitted with lighting.

The raw water is produced by mixing a concentrated suspension with fresh water. Depending on the mixing ratio, a raw water with the desired solids concentration is obtained. A stirring machine in the inlet area of the sedimentation tank prevents the solids from settling before entering the experiment section. The water level in the sedimentation tank can be adjusted continuously.

The device is completed by a lamella unit, which you can optionally place in the sedimentation tank. White and black lamellas are available, depending on the colour of the contaminants used.

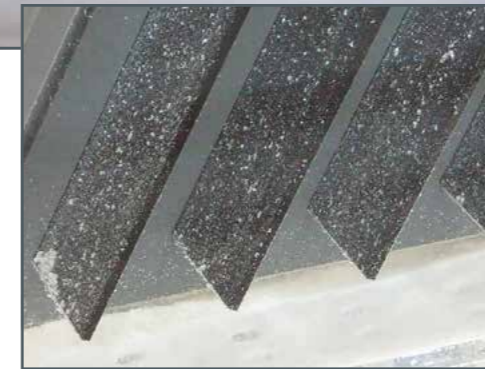

The sedimentation process and the flow conditions can be observed very clearly thanks to the use of transparent materials and lighting.



Optional lamella unit

About the product:



Learning objectives

- basic principle for the separation of solids from suspensions in a sedimentation tank
- determine the hydraulic surface loading
- influence of the following parameters on the separation process:
 - ▶ concentration of solids
 - ▶ flow rate
 - ▶ flow velocity in the inlet
 - ▶ water level in the sedimentation tank
- investigation of the flow conditions
- how lamellas affect the sedimentation process

HM 142

Separation in sedimentation tanks



2E

Description

- transparent sedimentation tank for observation of the separation process
- illumination for optimum visualisation of the flow conditions
- possible to use lamellas in the sedimentation tank

In sedimentation tanks, solids are separated out from suspensions under the influence of gravity. In this process the density of the solid particles must be greater than that of the liquid. HM 142 makes it possible to investigate the separation of solids from a suspension in a sedimentation tank.

First a concentrated suspension is prepared in a tank, comprising water and the solid to be separated. A pump transports the concentrated suspension to the sedimentation tank. Upstream of the sedimentation tank the suspension is mixed with fresh water. The raw water generated in this way flows into the sedimentation tank via an inlet weir. A stirring machine is located upstream of the inlet weir. This prevents solids sedimenting before entering the sedimentation tank. The treated water first flows under a baffle and then over a weir to the outlet.

The height of the weir on the outlet side is adjustable and allows the water level in the sedimentation tank to be changed. The water level above the inlet weir can also be adjusted. This affects the flow velocity over the inlet weir.

A lamella unit can be inserted into the experimental section. This makes it possible to study how lamellas affect the separation process. The flow through the lamellas occurs from bottom to top. Above the lamellas is an outlet channel. The side walls of the outlet channel are designed as a serrated weir.

The flow rates of the concentrated suspension and the fresh water are adjusted via valves. This means the mixing ratio, and thus the concentration of solids in the inlet to the sedimentation tank, can be adjusted. An electromagnetic flow rate sensor measures the flow rate in the inlet of the sedimentation tank. Flow rate and speed of the stirring machine are displayed digitally. The sedimentation tank is equipped with lighting to better observe the flow conditions.

Learning objectives/experiments

- basic principle for the separation of solids from suspensions in a sedimentation tank
- determine the hydraulic loading rate
- influence of the following parameters on the separation process:
 - ▶ concentration of solids
 - ▶ flow rate
 - ▶ flow velocity in the inlet
 - ▶ water level in the sedimentation tank
- investigation of the flow conditions
- how lamellas affect the sedimentation process

HM 142

Separation in sedimentation tanks

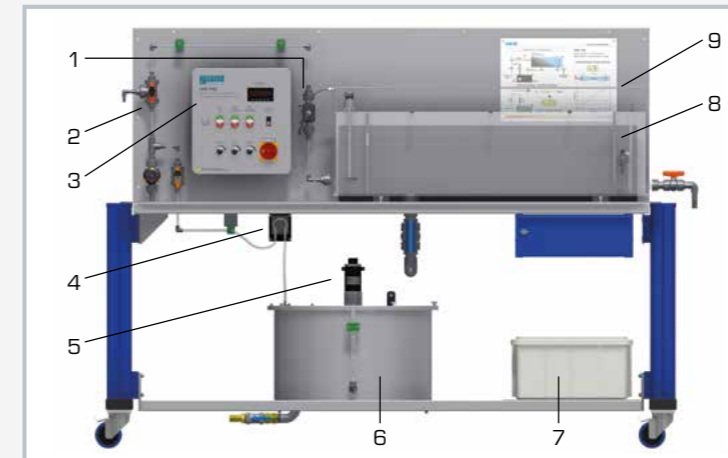

1 electromagnetic flow rate sensor, 2 sampling point, 3 switch box, 4 pump, 5 stirring machine, 6 suspension tank, 7 storage bin, 8 sedimentation tank, 9 illumination

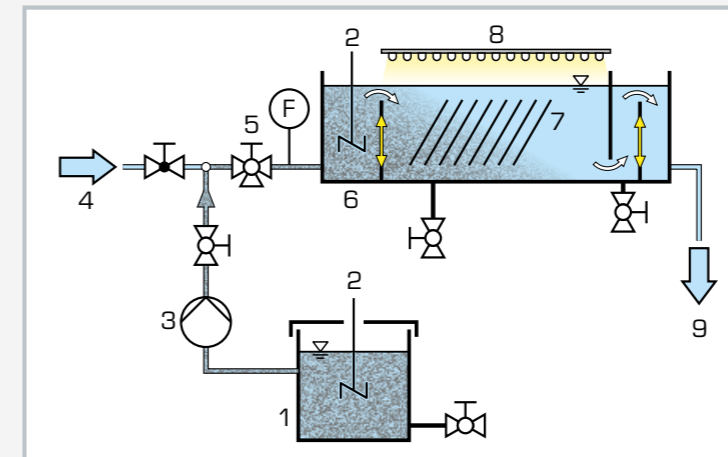

1 suspension tank, 2 stirring machine, 3 pump, 4 fresh water, 5 sampling point, 6 sedimentation tank, 7 lamellas (optional), 8 illumination, 9 outlet; F flow rate

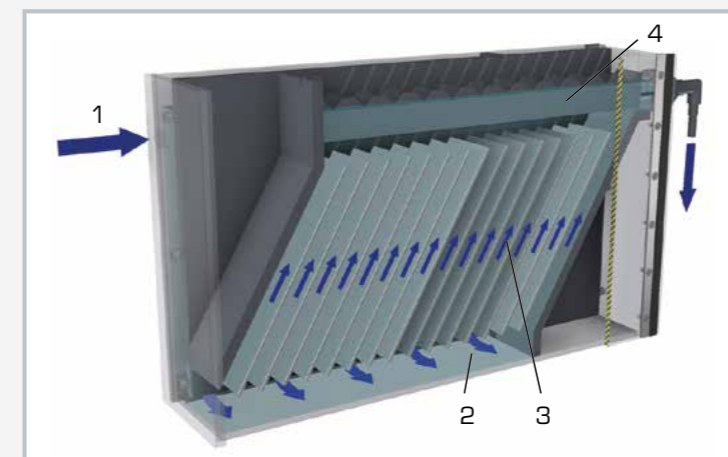

Functional principle of the lamella unit
1 raw water inlet, 2 raw water passes under the partition wall, 3 raw water flows up between the lamellas, solids sink onto the lamellas and slide down on the lamellas, 4 purified water flows into the drain channel

Specification

- [1] separation of suspensions by sedimentation in the sedimentation tank
- [2] transparent sedimentation tank with lighting for visualisation of the flow conditions
- [3] stirring machine in the inlet area of the sedimentation tank
- [4] lamella unit can optionally be inserted into the sedimentation tank
- [5] tank with pump and stirring machine to create and transport a concentrated suspension
- [6] mixture of the concentrated suspension with fresh water gives the raw water to be studied
- [7] adjustment of the concentration of solids via valves for fresh water flow rate and suspension flow rate
- [8] adjustable water level in the sedimentation tank and adjustable flow velocity in the inlet
- [9] electromagnetic flow rate sensor for raw water
- [10] Imhoff cones for determining settleable substances of a water sample

Technical data

Sedimentation tank (experimental section)

- LxWxH: 900x110x300mm
- max. filling capacity: approx. 25L
- material: plexiglass

Lamella unit

- angle of inclination of lamellas: 60°
- number of lamellas: 16

Suspension tank

- capacity: approx. 85L
- material: stainless steel

Pump

- max. flow rate: 75L/h

Stirring machines (max. speed)

- suspension tank: 600min⁻¹
- sedimentation tank: 330min⁻¹

Measuring ranges

- flow rate: 30...600L/h

230V, 50Hz, 1 phase
230V, 60Hz, 1 phase; 120V, 60Hz, 1 phase
UL/CSA optional
LxWxH: 2200x790x1540mm
Weight: approx. 220kg

Required for operation

water connection, drain

Scope of delivery

- 1 trainer
- 1 set of accessories
- 1 packing unit of solids
- 1 set of instructional material

Overview

CE 587 Dissolved air flotation

Removal of solids by flotation

Flotation, alongside sedimentation, is another process often used in water treatment to remove solids. Dissolved air flotation is the most commonly used flotation process.

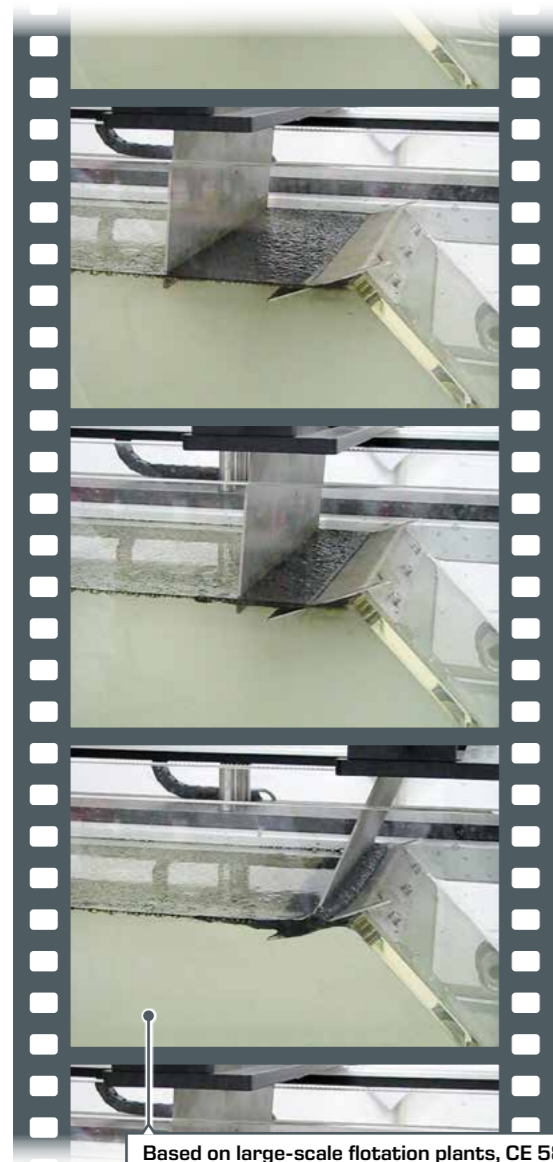

Based on large-scale flotation plants, CE 587 is equipped with an electrically driven scraper which removes the floated solids from the surface of the water.

Experiments with great practical relevance

Our CE 587 teaching unit allows you to study all important aspects of this process. In order to create high practical relevance, we have placed great emphasis on the highest possible realism in the development of this device.

The device consists of a supply unit and a trainer. First, the raw water is pre-treated by flocculation. Then the flocs are transported to the surface of the water in the flotation tank by means of small air bubbles. An electrically driven scraper allows you to clear the water surface of the floating substances. Many of the components used, such as electromagnetic flow rate sensors and metering pumps, are also used in large-scale industrial plants. By using transparent materials you can optimally observe all the stages in the process.



Supply unit



Standard at GUNT:
use of high-quality industrial components such as professional metering loading rate (rising velocity) pumps

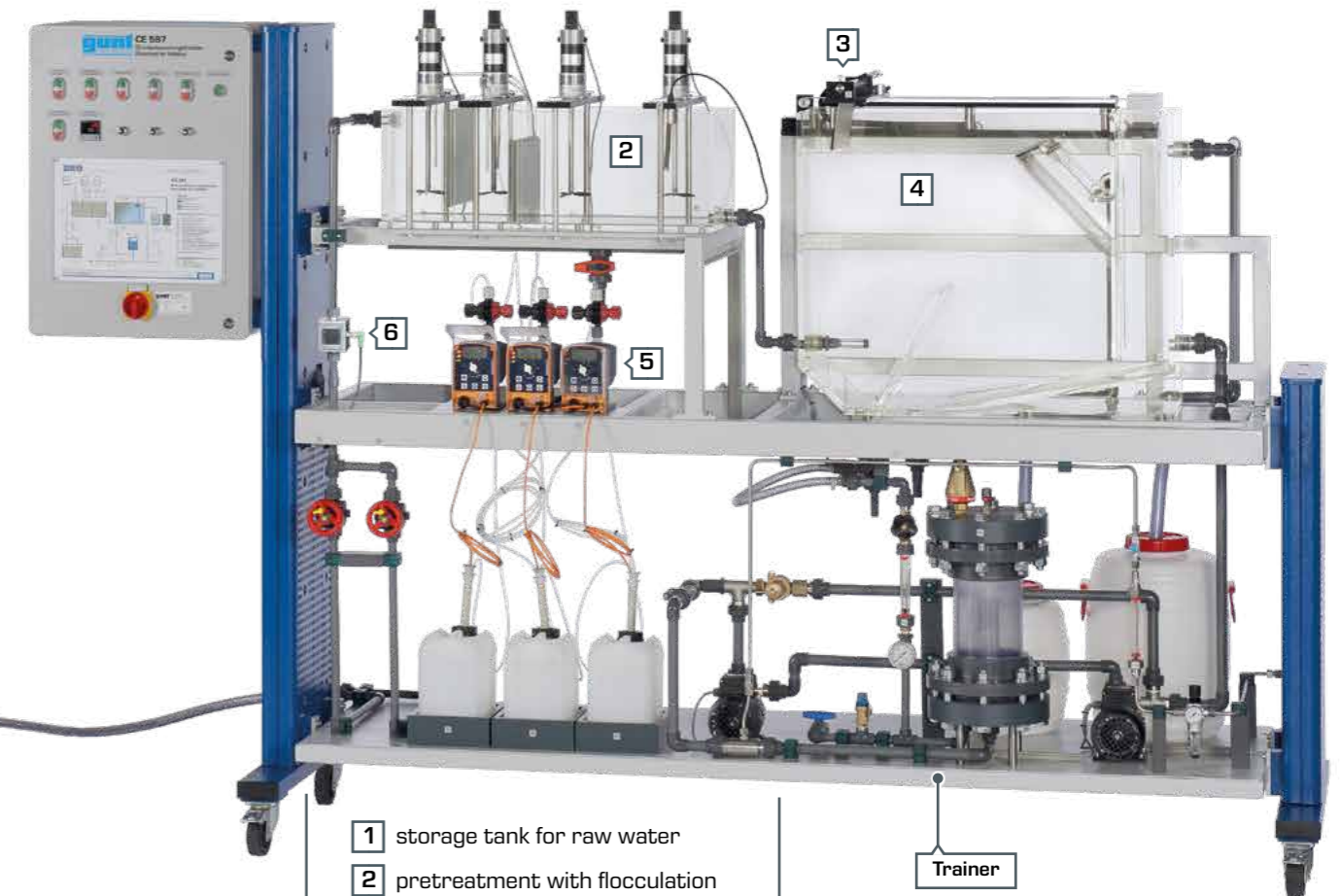

- 1 storage tank for raw water
- 2 pretreatment with flocculation
- 3 electrically driven scraper
- 4 flotation tank
- 5 metering pumps
- 6 electromagnetic flow meter

Trainer

Learning objectives

- functional principle of dissolved air flotation
- creation of a stable operating state
- effects of the coagulant and flocculant concentration
- determination of the hydraulic loading rate (rising velocity)

About the product:



CE 587

Dissolved air flotation



The illustration shows: supply unit (left) and trainer (right)

Description

- demonstration of dissolved air flotation
- flocculation to condition the raw water
- scraper to remove the float

CE 587 demonstrates the clarification of raw water containing solids using the dissolved air flotation process.

First, a suspension (raw water) is prepared in a tank. From here the raw water flows into a flocculation tank divided into three chambers. By adding a coagulant in the first chamber the repulsive forces between the solid particles are cancelled out. The solid particles combine into flocs. To create larger flocs a flocculant is added in the second chamber. The coagulant causes a drop of the pH value. By adding caustic soda the pH value of the water can be increased again. In the following third chamber of the flocculation tank low flow velocities are present to prevent any turbulence. Turbulence would impede the formation of flocs.

From the flocculation tank the raw water enters the flotation tank. A part of the treated water is removed from the flotation tank and saturated with air under pressure. This water (recycle water) enters via a relief valve so that it suddenly expands to atmospheric pressure. This creates minute air bubbles which attach to the flocs. This makes the flocs rise to the surface of the water. Using a scraper the floating flocs (float) can be moved into a collection channel.

Flow rates, pressures and pH values are measured. The pH value can additionally be controlled. The pressure of the recycle water can be adjusted.

Trivalent metallic salts are usually well suited as coagulants. Common flocculants are organic polymers. Powdered activated carbon can be used to produce the raw water.

Learning objectives/experiments

- functional principle of dissolved air flotation
- creation of a stable operating state
- effects of various parameters
 - ▶ coagulant concentration
 - ▶ flocculant concentration
- determination of the hydraulic loading rate (rising velocity)

CE 587

Dissolved air flotation

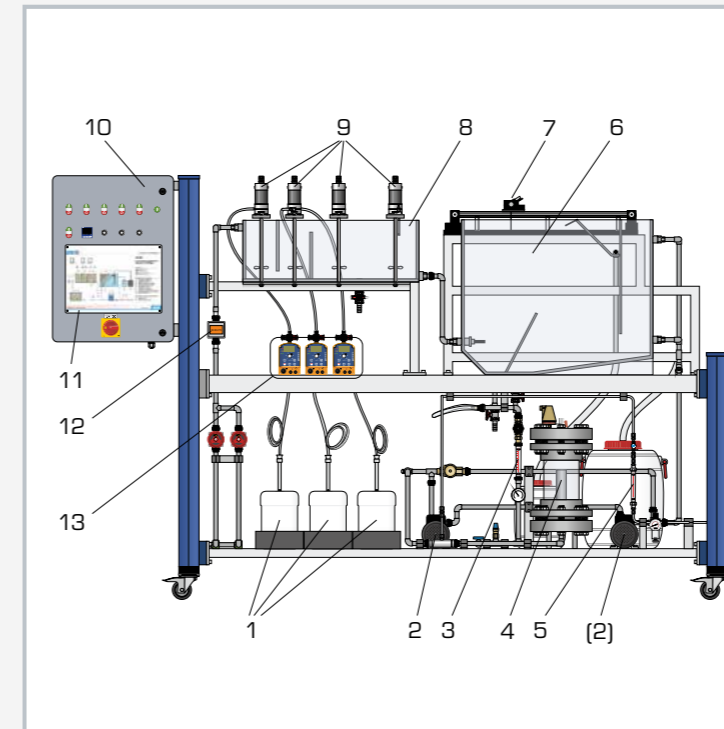

1 chemical tanks, 2 circulation pumps, 3 flow meter (recycle water), 4 pressure tank, 5 flow meter (air), 6 flotation tank, 7 scraper, 8 flocculation tank, 9 stirring machines, 10 switch cabinet, 11 process schematic, 12 electromagnetic flow rate sensor (raw water), 13 metering pumps

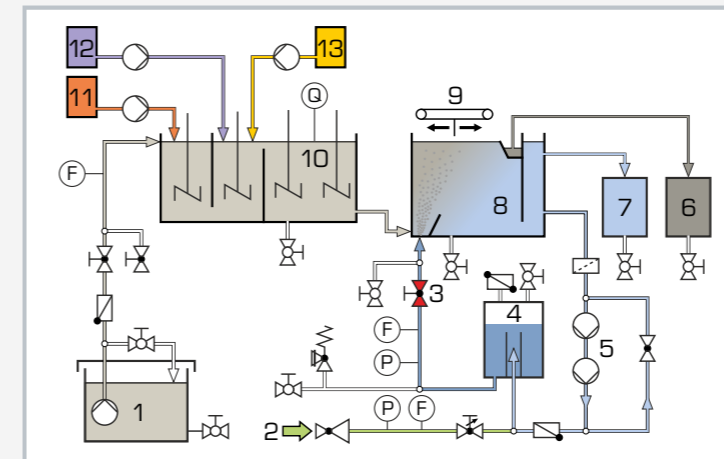

1 raw water, 2 compressed air, 3 relief valve, 4 pressure tank, 5 circulation pumps, 6 sludge (float), 7 treated water, 8 flotation tank, 9 scraper, 10 flocculation tank, 11 coagulant, 12 flocculant, 13 caustic soda; F flow rate, P pressure, Q pH value

Specification

- [1] removal of solids from raw water using dissolved air flotation
- [2] conditioning of the raw water by flocculation
- [3] 3 Metering pumps for chemicals
- [4] flocculation tank with 3 chambers and 4 stirring machines
- [5] flotation tank with electrically driven scraper
- [6] pressure tank and 2 circulation pumps
- [7] relief valve
- [8] separate supply unit with tank and pump for raw water
- [9] electromagnetic flow rate sensor
- [10] measurement of flow rate, pressure and pH value
- [11] control of the pH value

Technical data

Tanks

- flotation tank: 150L
- flocculation tank: 45L
- raw water: 300L
- treated water: 80L
- sludge (float): 15L

Raw water pump

- max. flow rate: 135L/min
- max. head: 7,0m

Circulation pumps

- max. flow rate: each 18L/min
- max. head: each 50m

Metering pumps

- max. flow rate: each 2,3L/h

Stirring machines

- max speed: each 600min⁻¹

Measuring ranges

- flow rate: 0,5...10L/min (raw water)
- flow rate: 30...320L/h (recycle water)
- flow rate: 20...360L/h (air)
- pH value: 1...14
- pressure: 0...6bar (recycle water)

230V, 50Hz, 1 phase

230V, 60Hz, 1 phase; 120V, 60Hz, 1 phase

UL/CSA optional

LxWxH: 1560x790x1150mm (supply unit)

LxWxH: 3100x790x1950mm (trainer)

Total weight: approx. 550kg

Required for operation

water connection, drain, compressed air, caustic soda, iron(III) sulfate, flocculant, powdered activated carbon (recommendation)

Scope of delivery

- 1 supply unit
- 1 trainer
- 1 set of hoses
- 1 set of instructional material

CE 588

Demonstration of dissolved air flotation



Learning objectives/experiments

- how dissolved air flotation works
- dissolving gases in liquids:
 - ▶ Henry's law
 - ▶ Dalton's law

2E

Description

- mechanical water treatment
- transparent tank for observing the processes

Flotation processes are used to separate solids from a liquid (e.g. water). The flotation process most commonly used in water treatment is dissolved air flotation.

The suspension to be treated (raw water) is placed in a tank. Flocculation chemicals can be added to the raw water in order to improve the flotation of the contaminants. A pump transports the raw water, which enters the flotation column via a vertical pipe. The height of the supply line can be adjusted.

A water circuit with pump is connected to the flotation column. At the highest point of the circulation there is negative pressure. The required air for the flotation is sucked in by opening a valve located at this point. The air dissolves in the water under pressure. Part of the water flows back to the pump via a bypass. The other part of the water enters a pressure vessel filled with Pall rings. The pressure vessel ensures a sufficiently long dwell time to dissolve the air and to separate undissolved air. The water then enters the flotation column from below via a valve. This causes a sudden drop in pressure to almost atmospheric pressure.

Since the solubility of air increases with increasing pressure, the excess air forms small bubbles. The air bubbles accumulate on the contaminants. The contaminants rise up in the column together with the air bubbles. At the upper end of the flotation column, the contaminants enter a circulating channel. The treated water is taken from the bottom of the flotation column and collected in a tank.

The pressure and the flow rate of the circulation can be adjusted. Flow rate, temperature and pressure are measured and displayed.

CE 588

Demonstration of dissolved air flotation

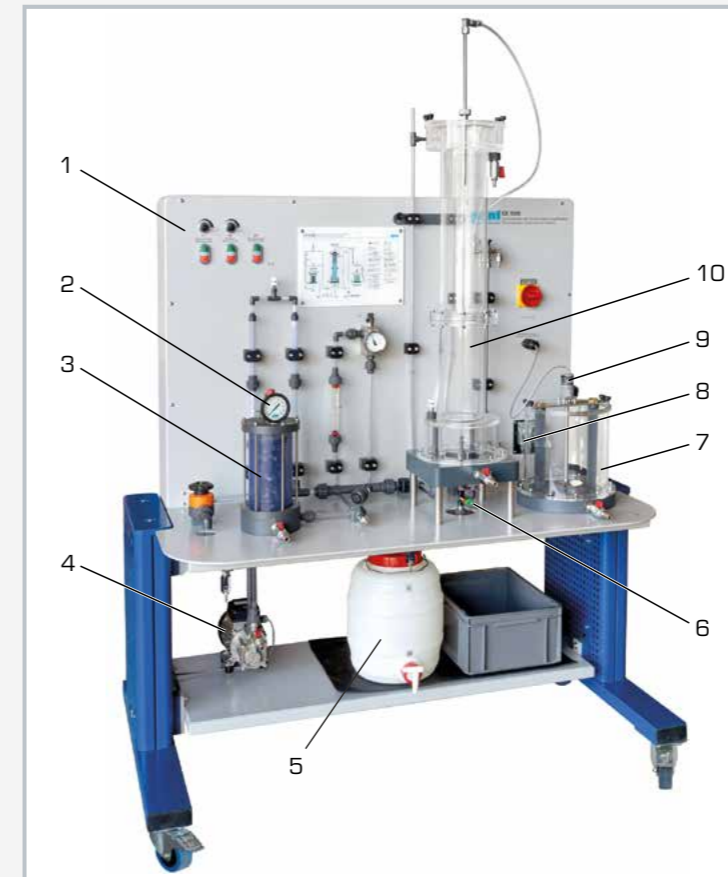

1 control elements, 2 manometer, 3 pressure vessel, 4 circulation pump, 5 treated water tank, 6 relief valve, 7 raw water tank, 8 raw water pump, 9 stirring machine, 10 flotation column

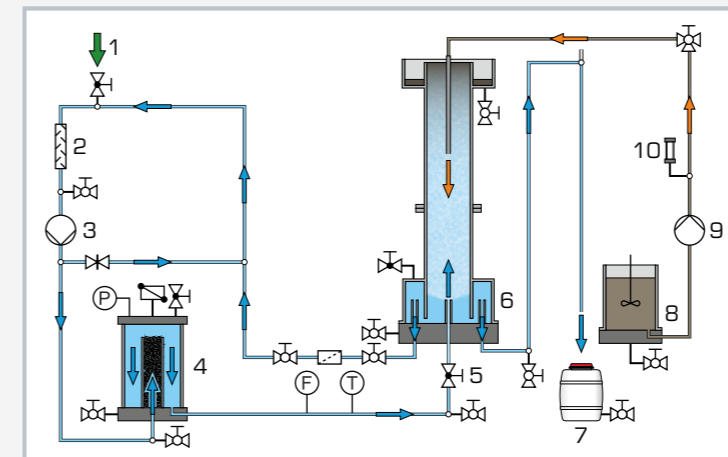

1 air, 2 static mixer, 3 circulation pump, 4 pressure vessel, 5 relief valve, 6 flotation column, 7 treated water tank, 8 raw water tank, 9 raw water pump, 10 pulsation dampener; F flow rate, P pressure, T temperature

Specification

- [1] flotation column made of plexiglass
- [2] raw water tank with stirring machine
- [3] peristaltic pump for pumping raw water
- [4] pulsation dampener to create a smooth raw water flow
- [5] continuously adjustable speeds of peristaltic pump and stirring machine
- [6] height-adjustable inlet for raw water into the flotation column
- [7] pressure and flow rate of the circulation adjustable
- [8] water circuit with pump and bypass
- [9] no compressed air required
- [10] transparent pressure vessel with Pall rings
- [11] measurement of flow rate, pressure and temperature

Technical data

Flotation column

- inner diameter: 115mm
- height: 870mm
- volume: approx. 10L

Tanks

- raw water: 8L
- treated water: 15L
- pressure vessel: 1,5L

Raw water pump (peristaltic pump)

- max. flow rate: 20L/h
- max. speed: 200min⁻¹

Circulation pump (centrifugal pump)

- max. flow rate: 660L/h
- max. head: 65m

Stirring machine: max. 330min⁻¹

Measuring ranges

- flow rate: 5...60L/h
- pressure: 0...10bar
- temperature: 0...60°C

230V, 50Hz, 1 phase
230V, 60Hz, 1 phase
120V, 60Hz, 1 phase
UL/CSA optional
LxWxH: 1410x790x1850mm
Weight: approx. 170kg

Scope of delivery

- 1 trainer
- 2 measuring cup
- 1 nutshell granules
- 1 iron(III) chloride
- 1 flocculant
- 1 storage box
- 1 set of instructional material

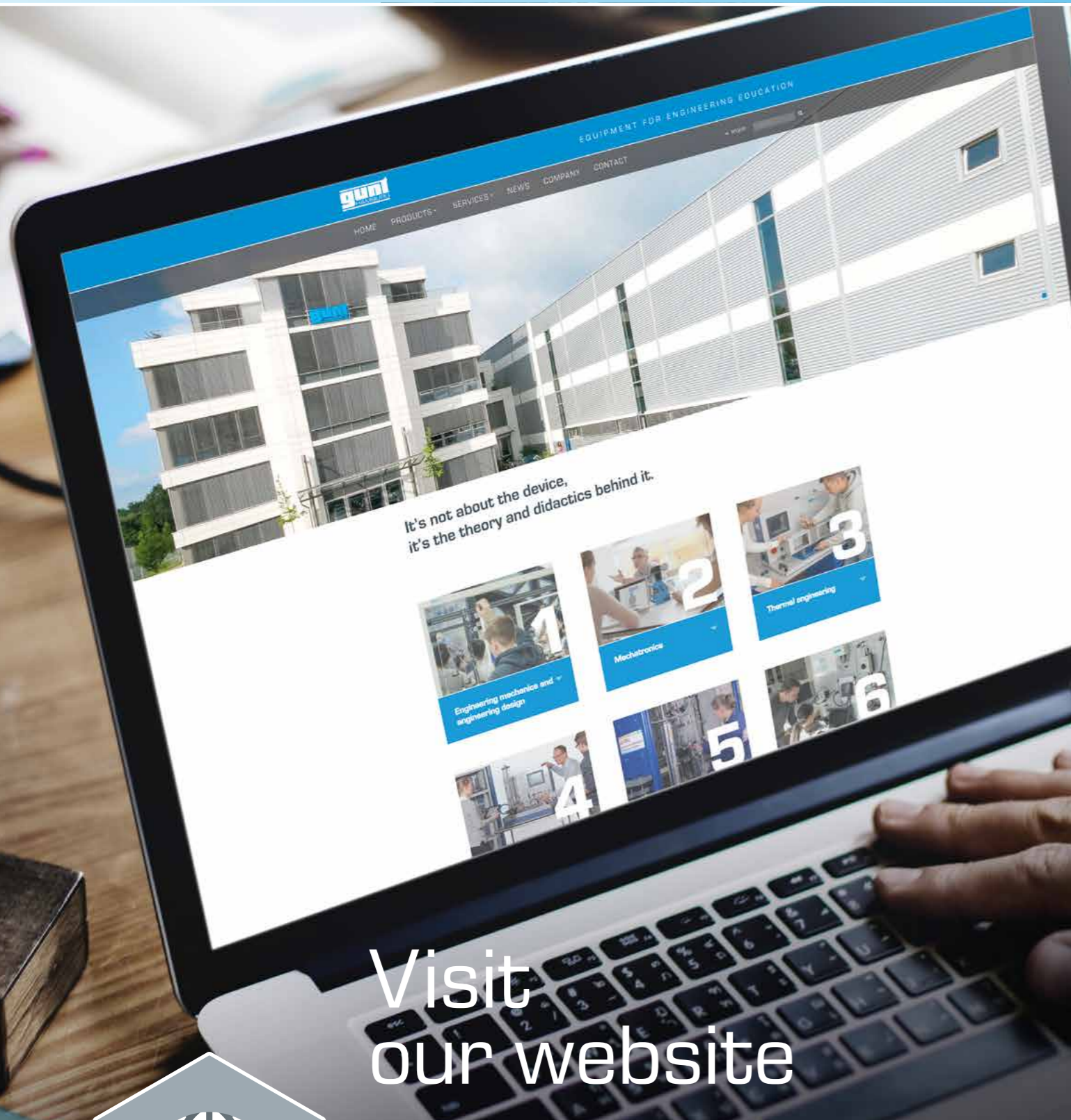

Visit
our website

On our website you will find all you need to know,
including all the latest news.

Basic knowledge

Separation in a centrifugal force field

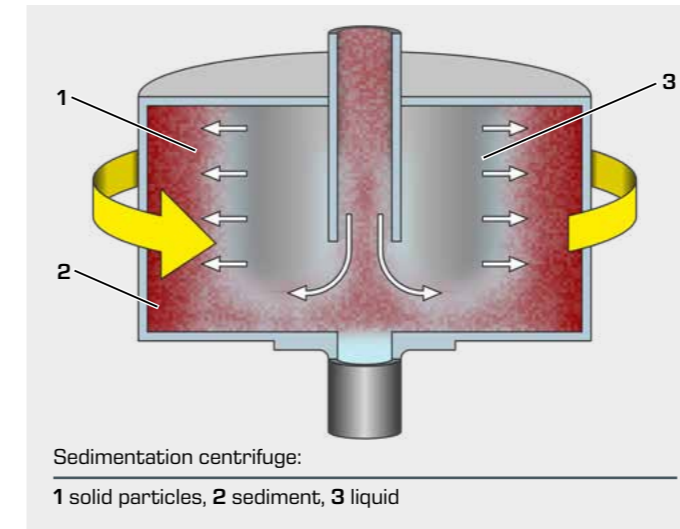

Sedimentation and filter centrifuges can be used to separate solid / liquid compounds:

In **sedimentation centrifuges**, the solid particles collect as sediment on the jacket wall. Sedimentation centrifuges may also have internal fittings such as inclined discs set at an oblique angle to the centrifugal force field (disc centrifuges). This layout reduces the settling distance and time. Disc centrifuges can also be used to separate emulsions such as water and oil.

In **cyclones**, the centrifugal force needed for separation is achieved by guiding the fluid flow. Cyclones are cylindrical at the top and taper downwards.

The solid-laden fluid enters the cyclone tangentially at the top and is forced into a revolving flow by the cyclone wall. A rotating (primary), downward-moving vortex is created. At the bottom of the cyclone the primary vortex is reversed. As the secondary vortex, the fluid moves upwards in the centre of the cyclone towards the immersion tube, where it exits. The main separation process takes place in the primary vortex. Owing to the centrifugal forces and the difference in density between the fluid and the solid, the solid particles move towards the wall.

In a **gas cyclone**, the solid particles slide downwards and collect at the bottom. Gas cyclones are in widespread use because they can also be used to separate solids from hot gases.

In a **hydrocyclone**, the solid-enriched portion of the liquid close to the wall spirals downwards to the bottom where - in contrast to the gas cyclone - it is continuously discharged. Hydrocyclones are used, for example, in the cleaning of contaminated soils.

As well as gravity, centrifugal force can also be used as the driving force for phase separation processes. The centrifugal force can be generated either by guiding the flow of the fluid, or by rotating vessels (centrifuges). The difference in density between the fluid and the solid particle results in the separation. The higher-density solid particles are drawn outwards by the centrifugal force more strongly than the fluid particles.

The forces occurring in the centrifugal force field of a **centrifuge** may be many times higher compared to those produced by gravity. Consequently, smaller, specifically lighter particles can be separated in a centrifugal force field than in a gravity field.

In **filter centrifuges**, the jacket of the rotating vessel has holes in it. On the inside of the jacket is a filter medium (a fine sieve or filter cloth). The centrifugal forces drive the suspension towards the filter medium, where the solid particles form a filter cake.

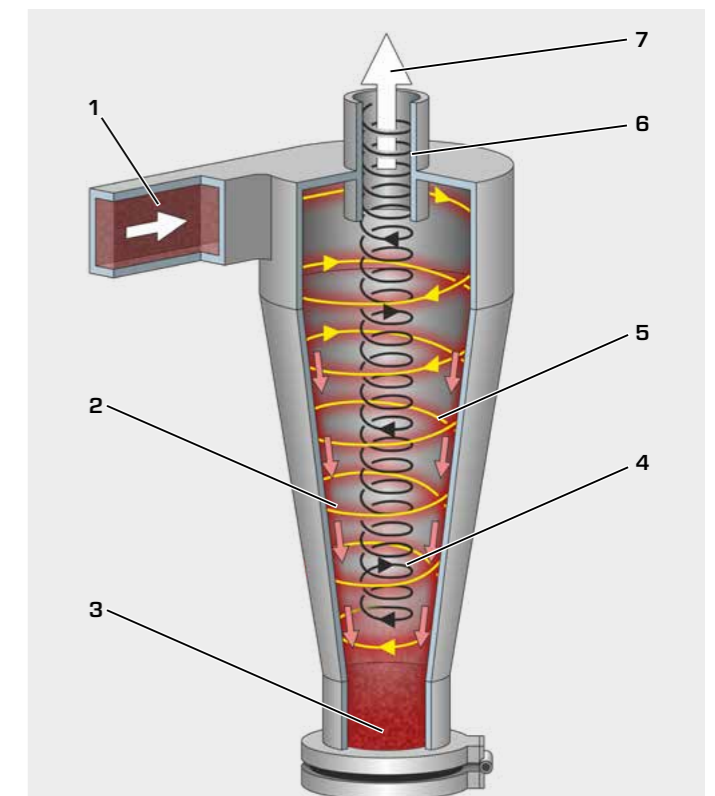

Gas cyclone:

1 raw gas, 2 separated dust,
3 collected dust, 4 secondary vortex, 5 primary vortex
6 immersion tube, 7 dedusted gas

CE 282
Disc centrifuge**Description**

- continuous separation of emulsions
- maintenance and inspection exercises possible
- practical experiments on a laboratory scale

A disc centrifuge can be used to separate mixtures of immiscible liquids.

The emulsion to be separated is prepared in a stirred tank. Water/oil is recommended for use as the emulsion. A stirring machine with a speed control mixes the two liquid phases. In the course of the mixing process the oil droplets are distributed ever more finely in the water. When the droplet sizes are smaller the emulsion remains stable for longer.

A pump delivers the emulsion up into the centre of the rotating centrifuge. The emulsion is delivered by way of the distributor base via riser ducts into the disc intermediate chambers. The driving force of the separation process is centrifugal force. It ensures that the specifically heavier liquid droplets (water) are drawn more strongly towards the outside than the specifically lighter liquid droplets (oil).

The settling distance and time are shortened by the disc arrangement set at an oblique angle to the field of acceleration. On the underside of the rotating discs the specifically heavier portion of the emulsion moves downwards and outwards. The lighter portion flows inwards on the top side of the discs. The separated liquids exit the centrifuge by way of outlets and can be collected in tanks.

The rotation speed of the centrifuge can be adjusted by way of a potentiometer. A valve is used to adjust the flow rate of the emulsion due to be separated. Various types of stirrer are available to perform the stirring. A photometer is recommended for analysis of the separated fractions.

The operating and service instructions form the basis for learning how to perform an extensive range of maintenance and inspection operations on the centrifuge.

Learning objectives/experiments

- production of stable emulsions with different types of stirrer
- learning the fundamental principle of disc centrifuges
- influence of rotation speed and feed flow rate on separation result
- characteristic of concentration of the light phase in the stirred tank over time (with photometer)
- startup/shutdown and operation of a disc centrifuge
- maintenance
- cleaning
- inspection

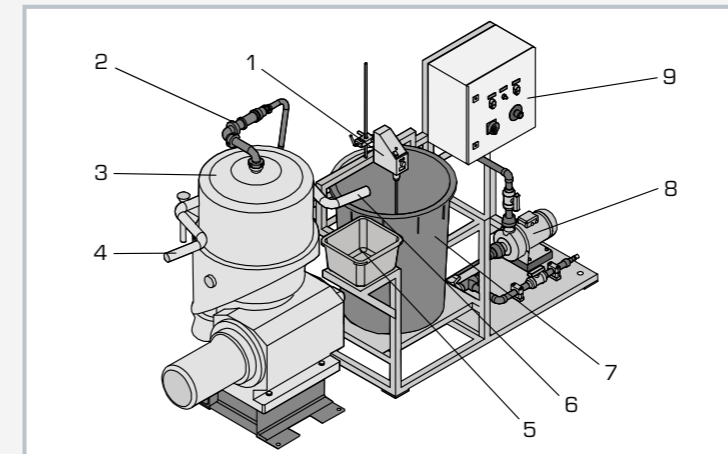
CE 282
Disc centrifuge

1 stirring machine, 2 emulsion inlet, 3 centrifuge, 4 light phase outlet, 5 light phase collector tank, 6 heavy phase outlet, 7 stirred tank, 8 pump, 9 switch box with controls

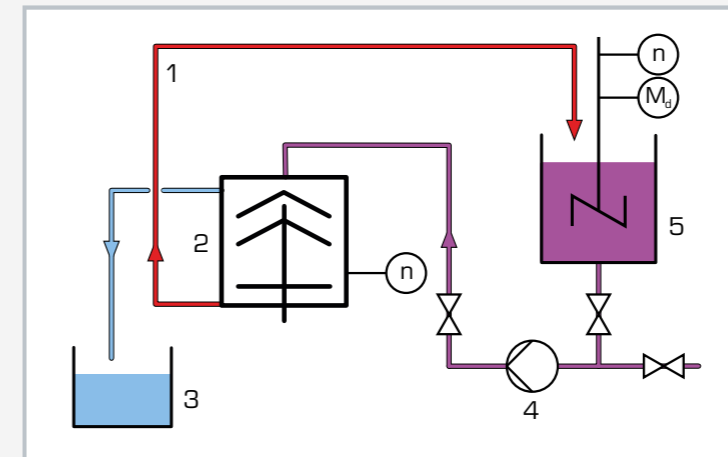

1 heavy phase, 2 disc centrifuge, 3 light phase, 4 pump, 5 emulsion stirred tank; n speed, M_t torque

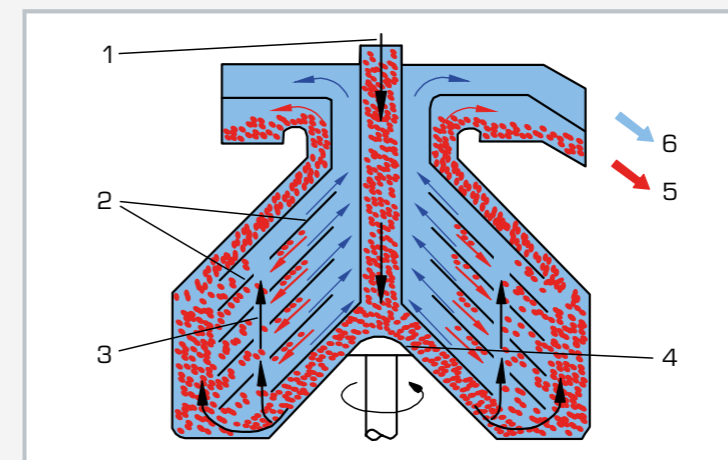

Fundamental principle of disc centrifuges: 1 emulsion inlet, 2 discs, 3 riser duct, 4 inlet base, 5 heavy phase outlet, 6 light phase outlet

Specification

- [1] continuous separation of emulsions with a disc centrifuge
- [2] HDPE tank with stirring machine to produce an emulsion
- [3] centrifugal pump to deliver the emulsion to the centrifuge
- [4] adjustment of emulsion flow rate by valve
- [5] centrifuge speed adjustable by potentiometer
- [6] speed-controlled stirring machine with digital torque indicator
- [7] 3 interchangeable stirrers
- [8] collector tank for separated phase

Technical data**Disc centrifuge**

- power consumption: 7500W
- max. usable diameter: approx. 300mm
- max. speed: 6480rpm

Stirring machine

- power consumption: 140W
- speed: 30...1000rpm

Stirrer

- 2x paddle stirrers: 3/ 10 holes
- 1x stirrer with 3 blades

Centrifugal pump

- max. flow rate: 300L/min
- max. head: 9,5m

Tanks

- stirred tank: 200L
- collector tank: 14L

Measuring ranges

- speed:
 - ▶ 1x 0...8000min⁻¹
 - ▶ 1x 30...1000min⁻¹
- torque: 0...200Ncm

400V, 50Hz, 3 phases
400V, 60Hz, 3 phases; 230V, 60Hz, 3 phases
UL/CSA optional
LxWxH: 3000x1000x1800mm
Weight: approx. 1100kg

Required for operation

water connection: 200...300L/h, drain; special foundations and drainage required

Scope of delivery

- 1 trainer
- 1 set of accessories
- 1 set of instructional material

CE 235

Gas cyclone



The illustration shows: trainer (left) and fan (right).

Description

- solid separation with a gas cyclone
- transparent cyclone to observe the separation process
- practical experiments on a laboratory scale

One area of application of gas cyclones is the pre-filtration of solids from gases. Gas cyclones have no moving parts, and so are low-maintenance systems. Gas cyclones can also be used in conjunction with high gas temperatures. For these reasons they are in widespread use.

This trainer was developed in cooperation with the **Institute for Solids Process Engineering and Particle Technology at TU Hamburg-Harburg**. A disperser is used to disperse the feed material (quartz powder recommended) finely in an air flow. The air flow laden with solid material (raw gas) in this way is fed tangentially into the cyclone at the top. In the cyclone, the air flow moves downwards as a rotating primary vortex. At the bottom of the cyclone the vortex is reversed. In the middle of the cyclone it moves as a secondary vortex back up towards the immersion tube, where the cleaned gas emerges from the cyclone. The main separation process takes place in the primary vortex.

Owing to the centrifugal forces and the difference in density between the air and the solid, the coarse solid particles move towards the wall. They slide down the wall and are collected in a tank at the bottom of the cyclone. No complete separation of the entire solid material takes place. The fine particles which are smaller than the separation size are ideally discharged from the immersion tube at the top with the secondary vortex. This fine material is separated out of the air flow by a filter. The separation size defines the theoretical boundary between the fine and coarse material.

The solid content of the raw gas can be adjusted by means of the disperser and a valve for the volumetric air flow rate. To prevent loading of the air flow with particles upstream of the disperser, the drawn-in room air is filtered. A fan generates the air flow. Pressure measurement points at the relevant positions in the trainer enable to determine the pressure loss.

Using a suitable analysis device (such as a diffraction spectrometer), a separation function can be produced and the separation size determined.

Learning objectives/experiments

- influence of solid content and volumetric air flow rate on
 - ▶ pressure loss at the cyclone
 - ▶ separation efficiency
 - ▶ separation function and separation size (with suitable analysis device)
- comparison of pressure loss and separation efficiency with theoretically calculated values

CE 235

Gas cyclone

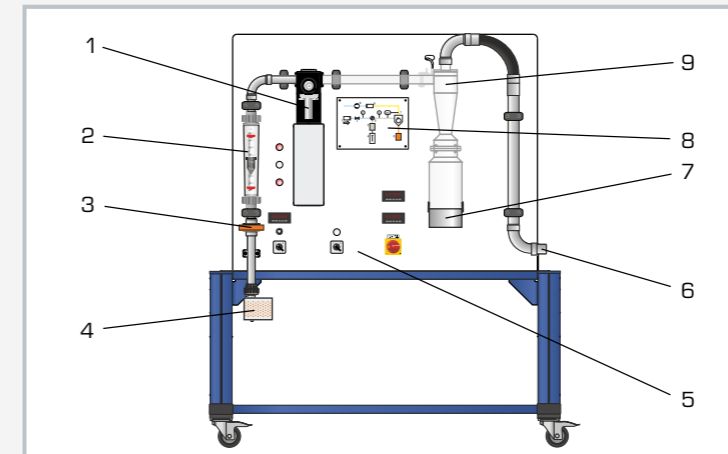

1 disperser with feed material tank and transport unit, 2 flow meter, 3 valve (air flow rate), 4 air inlet with filter, 5 displays and controls, 6 connection for fan, 7 coarse material tank, 8 process schematic, 9 gas cyclone

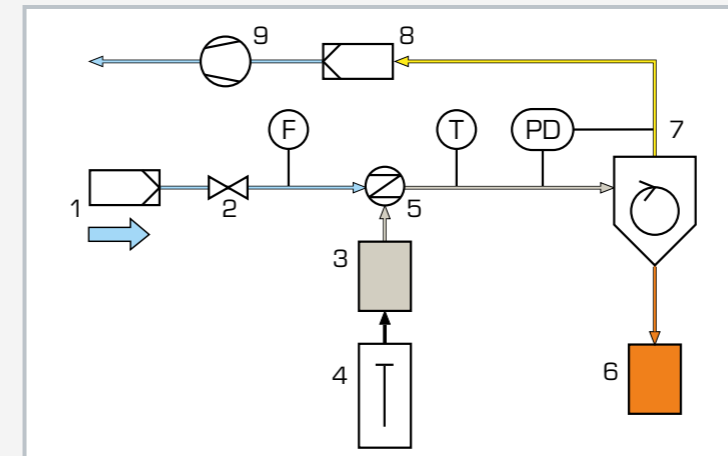

1 air inlet with filter, 2 valve (air flow rate), 3 feed material tank, 4 transport unit, 5 disperser, 6 coarse material tank, 7 gas cyclone, 8 fine material filter, 9 fan; F volumetric flow rate, PD differential pressure, T temperature

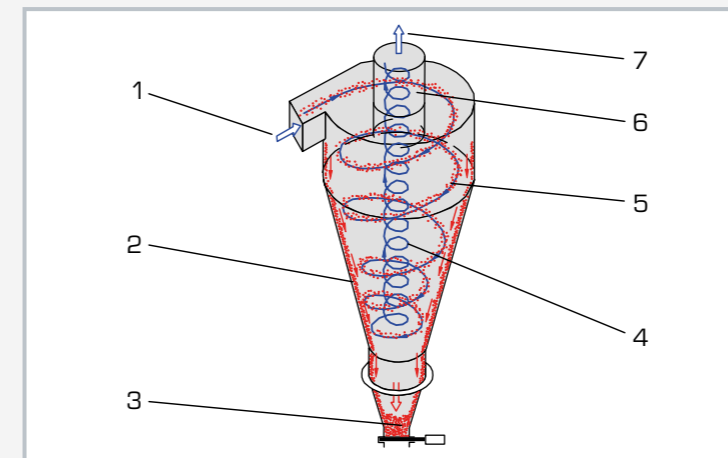

Flow conditions in a gas cyclone: 1 raw gas inlet, 2 separated solid, 3 collected solids, 4 secondary vortex, 5 primary vortex, 6 immersion tube, 7 cleaned gas

Specification

- [1] solid separation from gases with a cyclone
- [2] cyclone with tangential inlet
- [3] metering of feed material into the air flow with a disperser
- [4] air flow generation by fan; adjustment by valve
- [5] tanks for feed material and coarse material
- [6] 1 filter at air inlet and 1 filter for fine material at air outlet
- [7] recording of differential pressure, volumetric air flow rate and temperature

Technical data

Cyclone

- height: approx. 250mm
- diameter: approx. 80mm
- immersion tube diameter: approx. 30mm

Fan

- volumetric flow rate: max. 600m³/h
- power consumption: approx. 3600W

Tanks

- feed material: 15mL
- coarse material: 700mL

Measuring ranges

- differential pressure: 0...100mbar
- volumetric flow rate: 10...100m³/h (air)
- temperature: 0...60°C

230V, 50Hz, 1 phase
 230V, 60Hz, 1 phase; 120V, 60Hz, 1 phase
 UL/CSA optional
 LxWxH: 1520x790x1800mm (trainer)
 Weight: approx. 160kg (trainer)
 LxWxH: 660x510x880mm (fan)
 Weight: approx. 33kg (fan)

Scope of delivery

- 1 trainer
- 1 fan
- 1 packing unit of quartz powder (0...0,16mm; 25kg)
- 1 filling aid for disperser
- 1 set of accessories
- 1 set of instructional material

CE 225 Hydrocyclone



Learning objectives/experiments

- fundamental principle and the method of operation of a hydrocyclone
- solid mass flow rate in feed, overflow and underflow
- liquid mass flow rate in feed, overflow and underflow
- characteristic values for sharpness of separation
- pressure loss at the cyclone dependent on the feed flow rate
- influence of solids density on characteristic values and pressure loss

Description

- **solid separation with a hydrocyclone**
- **optimum observation of processes through transparent materials**
- **practical experiments on a laboratory scale**

Hydrocyclones can be used to separate solids suspended in liquids. In CE 225, the suspension is prepared in a tank. A pump delivers the suspension into the tangential inlet of the cyclone. In the cyclone a downward primary vortex is created. The downward taper causes the vortex to reverse. In the middle it moves as a secondary vortex back up towards the vortex finder, where the suspension emerges from the cyclone, having lost the coarse material in it. Inside the cyclone an air core is formed. The centrifugal forces cause the coarser solid particles in the primary vortex to be enriched.

They are discharged with the underflow at the apex nozzle. It is mainly the fine material that is discharged from the top.

The flow rate in the inlet is adjusted by a valve in a bypass and measured with an electromagnetic flow meter. Sampling points are installed at the underflow and overflow. The flow rates in them can be determined by means of a bucket and a stopwatch. To determine the solid concentration, a balance and a drying chamber are recommended. Using a suitable analysis device (such as a diffraction spectrometer), a separation function can be produced and the separation size determined. Quartz powder and diatomite are recommended for use as the solid.

The trainer was developed in cooperation with the **Department of Mechanical Process Engineering at Anhalt University of Applied Sciences**.

CE 225 Hydrocyclone

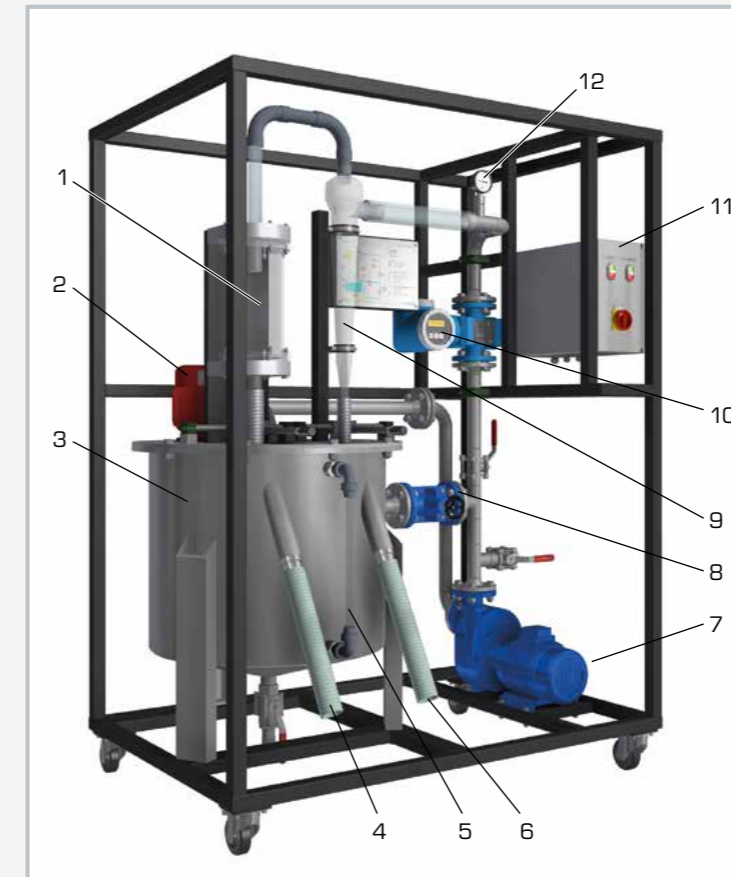

1 tank for observation of overflow, 2 stirring machine, 3 stirred tank, 4 overflow sampling point, 5 level indicator, 6 underflow sampling point, 7 pump, 8 valve in bypass, 9 hydrocyclone, 10 flow meter, 11 switch box, 12 manometer

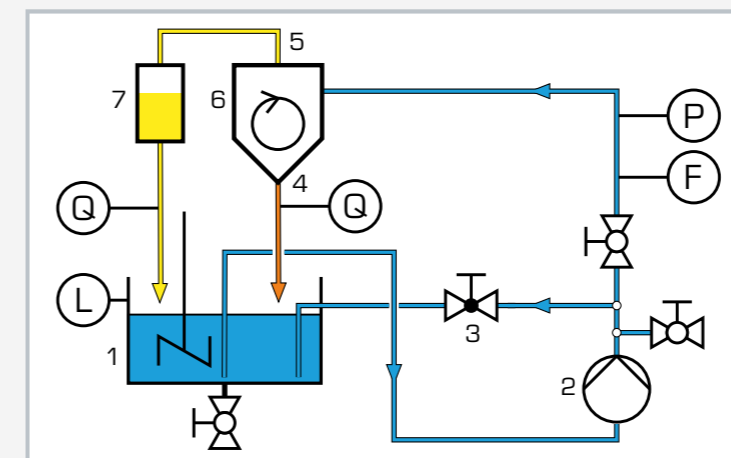

1 stirred tank, 2 pump, 3 valve in bypass, 4 underflow, 5 overflow, 6 hydrocyclone, 7 tank for observation of overflow; F flow meter, P manometer, L level indicator, Q sampling point

Specification

- [1] solid separation from liquids with a hydrocyclone
- [2] hydrocyclone with tangential inlet
- [3] stirred tank for preparation of suspensions
- [4] centrifugal pump to deliver the suspension
- [5] adjustment of flow rate by valve in bypass
- [6] electromagnetic flow meter at inlet
- [7] sampling points on the overflow and underflow to determine the flow rates and solid concentrations
- [8] manometer to determine the pressure loss at the cyclone

Technical data

Cyclone
 ■ height: 710mm
 ■ Ø: 114mm
 ■ vortex finder: Ø 40mm

Stirred tank
 ■ capacity: 200L
 ■ material: stainless steel

Overflow tank
 ■ capacity: 5L
 ■ material: PMMA

Pump
 ■ max. flow rate: 400L/min
 ■ max. head: 30m

Measuring ranges
 pressure: 0...4bar
 flow rate: 0...200L/min

400V, 50Hz, 3 phases
 400V, 60Hz, 3 phases
 230V, 60Hz, 3 phases
 UL/CSA optional
 LxWxH: 1500x1000x2020mm
 Weight: approx. 370kg

Scope of delivery

- 1 trainer
- 7 apex nozzles
- 1 hose
- 2 buckets
- 1 measuring cup
- 1 shovel
- 1 stopwatch
- 1 set of tools
- 1 packing unit of quartz powder (25kg)
- 1 packing unit of diatomite (20kg)
- 1 set of instructional material

Basic knowledge Filtration

Filtration is used to remove solids. The fundamental principle is that the solids are captured and retained by a filter medium. The liquid phase of the raw water passes through the filter, and is termed filtrate.

Surface filtration

Surface filtration is based on a screening effect. The solids do not penetrate the filter, but are held back on its surface. Therefore the pore width of the filter medium must be less than the size of the solid particles. Filter media used may be sieves, cloths, filter paper or membranes. If the flow is directed perpendicular to the surface, the term cake filtration is used. A filter cake builds up on the filter medium over time which reduces the flow rate of the filtrate. This is a disadvantage of this process. This

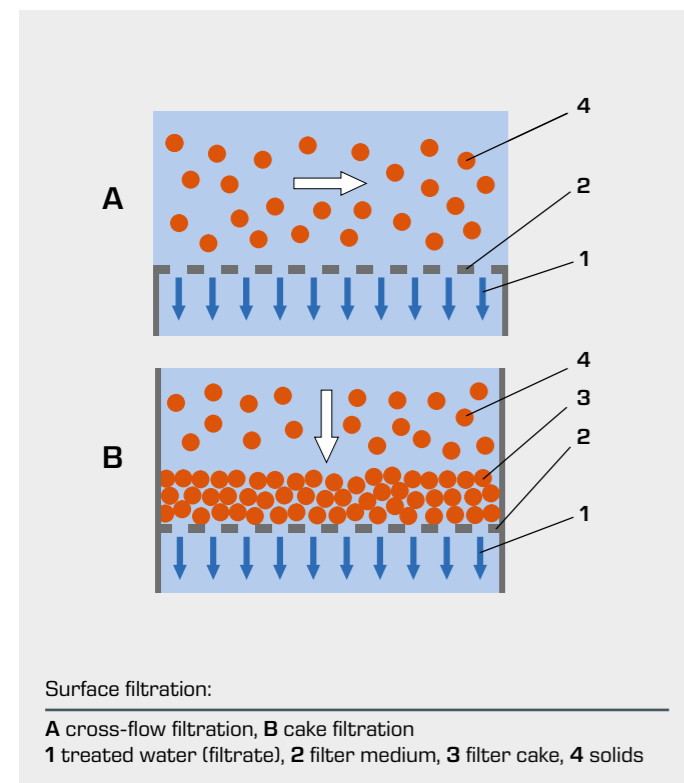

Depth filtration

In depth filtration, the raw water flows through a bed of granular material (filter bed) such as sand or gravel. As the raw water flows through the interstices between the grains of the filter medium, suspended solids are captured and retained. The treated water passes through the filter bed. Over time, more and more solids collect in the flow channels of the filter bed. This reduces the cross-sectional area of the flow channels increasing the hydraulic resistance of the filter to the flow. This resistance is expressed as a loss of pressure. The flow through the filter decreases, or it can only be maintained by increasing the pressure on the inflow side of the filter. The deposited solids can be

A fundamental distinction is made between depth filtration and surface filtration.

problem is countered in cross-flow filtration by causing the raw water to flow parallel to the surface. Deposits on the filter are then largely removed by the flow. This principle is applied primarily in the membrane separation processes.

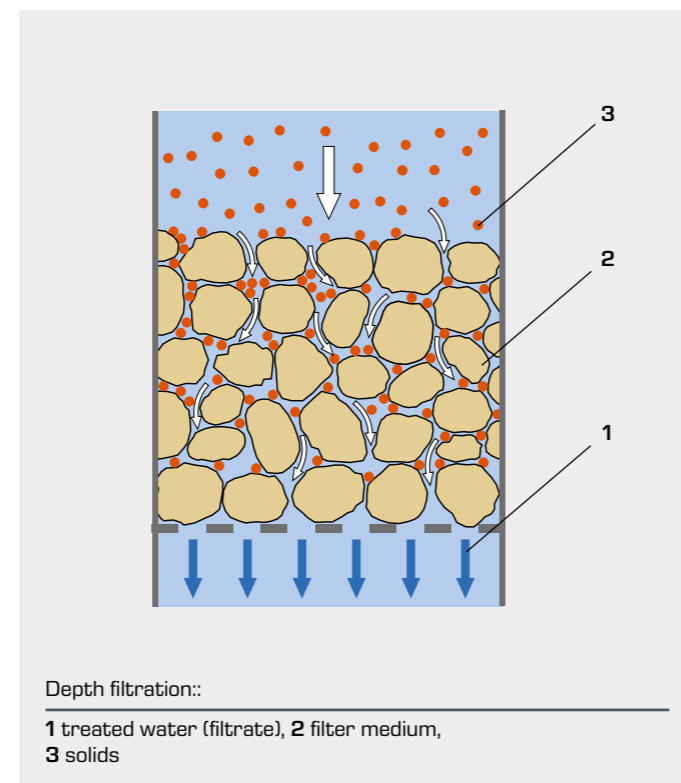

removed by backwashing them. Consequently, the pressure loss is reduced by a backwash. This process usually takes place with treated water in the opposite flow direction.

The pressure trend over time in a filter bed can be depicted by filter resistance diagrams – also known as Micheau diagrams.

CE 116 Cake and depth filtration



Description

■ cake and depth filtration with different suspensions and filter medium layers

With CE 116 the processes in depth filtration and cake filtration can be observed and investigated. The suspension (water and diatomite as the solid) flows from the hopper into the top of the filter element, where the solids are separated off.

The filtrate flows through a flow meter into the drain. The filter element has a porous filter medium at the bottom. In cake filtration, the filter medium provides the foundation for build-up of the filter cake. In depth filtration, the filter medium supports the bulk solids (filter medium layer; gravel). Twin tube manometers measure the pressure loss over the filter element.

To register the filtrate quantity, the balance CE 116.01 is recommended.

Learning objectives/experiments

- fundamentals of filtration: Darcy's equation
- depth filtration with different bulk solids and suspensions
- cake filtration with different suspensions
- identification of characteristic filtration values

Specification

- [1] fundamentals of cake and depth filtration
- [2] filter element with sintered filter medium on its bottom to capture the particles
- [3] pressure loss measurement with twin tube manometers
- [4] height-adjustable filler hopper made of DURAN glass
- [5] flow meter with needle valve for adjustment

Technical data

- Filter element
- filter chamber height: 85mm
 - Ø inner: approx. 37mm
 - cross-sectional area: approx. 11 cm²
 - tube material: DURAN glass

- Filter medium, sintered filter SIKA 100
- pore size: 100µm
 - thickness: 2mm
 - material: sintered metal

- Measuring ranges
- flow rate: 40...360mL/min
 - pressure: 2x 0...500mmWC
 - temperature: -10...100°C
 - measuring cup
 - ▶ 1x 1000mL, graduation: 10mL
 - ▶ 1x 100mL, graduation: 2mL

LxWxH: 450x410x1040mm
Weight: approx. 13kg

Required for operation

drain

Scope of delivery

- 1 experimental unit
- 2 measuring cups
- 1 stopwatch
- 1 thermometer
- 1 sand (1kg; 1...2mm)
- 1 packing unit of diatomite (2kg)
- 1 set of instructional material

CE 117

Flow through particle layers



Learning objectives/experiments

- learning the fundamentals of flow through fixed beds and fluidised beds (Darcy)
- determination of the permeability coefficient
- observation of the fluidisation process
- pressure loss dependent on the flow rate, type, particle size and height of the bulk solid
- determination of the fluidisation velocity and comparison with theoretically calculated values
- verification of Carman-Kozeny equation

Description

- experiments in the fundamentals of fluid mechanics on particle layers
- flow through fixed beds
- flow through fluidised beds
- pressure loss in fixed beds and fluidised beds

Flow through particle layers is widely encountered in process engineering. In reactors, fixed and fluidised beds are subjected to through-flow by liquids and gases. The separation of solids from suspensions by cake and depth filtration is another area of application.

With CE 117 the fluid mechanic principles involved in flow through fixed beds and fluidised beds can be investigated. For the purpose, a fillable test tank made of glass is provided, through which water can be made to flow from both ends. A sintered-metal plate serves as the base for bulk solids.

Water from the laboratory water connection flows into the test tank. To investigate flow through fixed beds, the water enters the test tank from the top. It flows through the fixed bed and the sintered-metal plate and passes by way of a distributor to the outlet.

The experimental setup can be modified by means of quick-release couplings. This also enables the flow through the test tank to be reversed and fluidised beds to be investigated. The water flows upwards through the porous sintered-metal plate and the fixed bed. If the velocity of the water is less than the so-called fluidisation velocity, the flow merely passes through the fixed bed. At higher velocities a fluidised bed is formed. The water flows from the head of the test tank into an expansion tank. From there it flows into the outlet.

Regardless of the specific setup, the flow rate is adjusted by a valve and indicated by a flow meter. To determine the pressure loss via the fixed bed or fluidised bed, two manometers with differing measuring ranges are provided. The desired manometer is selected by way of valves.

CE 117

Flow through particle layers

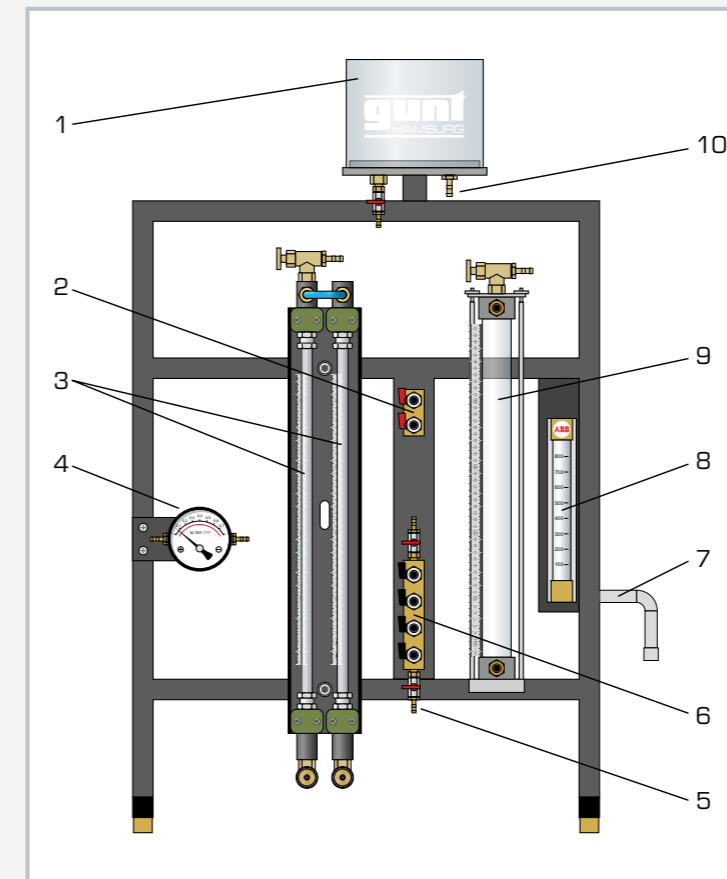

1 expansion tank, 2 inlet distributor, 3 tube manometer, 4 manometer, 5 outlet, 6 distributor or for pressure measurement, 7 inlet, 8 flow meter, 9 test tank, 10 outlet

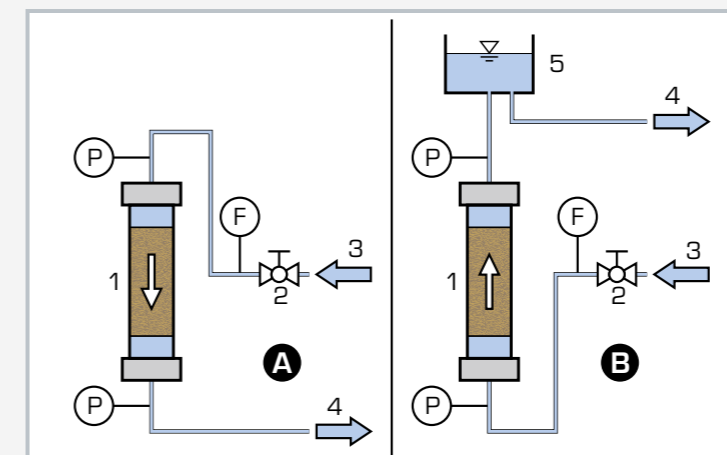

Process schematic for the investigation of fixed beds (A) res. fluidised beds (B): 1 test tank (particle layer), 2 valve (flow rate), 3 inlet, 4 outlet, 5 expansion tank; P pressure, F flow rate

Specification

- [1] investigation of the properties of fixed and fluidised beds subjected to liquid flow
- [2] glass test tank with sintered filter medium on its base
- [3] test tank removable for filling
- [4] downward flow to investigate fixed beds
- [5] upward flow to investigate fluidised beds
- [6] flow meter with valve for adjustment
- [7] 2 manometers with differing measuring ranges to measure pressure loss through the test tank
- [8] steel rule to measure the height of the fixed or fluidised bed

Technical data

Test tank

- length: 510mm
- inner diameter: approx. 37mm
- material: DURAN glass

Filter medium

- thickness: 2mm
- material: sintered metal

Expansion tank

- capacity: approx. 4500mL
- material: PVC

Measuring ranges

- flow rate: 82...820mL/min
- differential pressure:
 - ▶ 2x 0...500mmWC
 - ▶ 1x 0...250mbar
- height: 10...500mm

LxWxH: 690x410x1150mm
Weight: approx. 26kg

Required for operation

water connection: approx. 1L/min
drain

Scope of delivery

- 1 experimental unit
- 1 packing unit of glass-shot beads (420...590µm; 1kg)
- 1 packing unit of sand (1...2mm; 0,5kg)
- 1 packing unit of glass-shot beads (180...300µm; 0,5kg)
- 1 set of accessories
- 1 set of instructional material

CE 287

Plate and frame filter press



Description

- separation of solids from suspensions with a plate and frame filter press
- discontinuous cake filtration
- practical experiments on a laboratory scale

Plate and frame filter presses are used in the beverage industry, for example, to clarify intermediate products.

A suspension of diatomite and water (recommended) is prepared in a tank. A pump ensures that the solid remains suspended and does not settle. The pump delivers the suspension into the individual separating chambers of the plate and frame filter press. A separating chamber is formed by one filter frame and two filter plates. The filter plates are grooved and covered over with filter cloths. The filtrate passes through the filter cloth and flows via the grooves in the plates into a collecting pipe. The filtrate exits the plate and frame filter press through the collecting pipe and is collected in the filtrate tank. The solid material is separated off at the filter cloth, where it forms a growing filter cake.

As the filter cake becomes thicker, its flow resistance also increases. When the separating chamber is full, or a maximum pressure difference has been reached, the filtration process is ended. The plates and frames of the plate and frame filter press are pulled apart. The filter cake can be removed. For the next filtration the plates and frames must be pushed back together. A spindle is used to press them together. The press forces ensure that the suspension does not leak from the contact points between the plates and the frames, but is forced through the filter cloth.

The flow rate through the plate and frame filter press is adjusted by a valve. The pressure occurring during filtration is indicated on a manometer. The filtrate tank is scaled. This means a stopwatch can be used to measure the flow rate. An included opacimeter allows the solid concentration of the filtrate to be determined. A drying chamber is recommended for evaluation of the experiments.

Learning objectives/experiments

- learning the fundamental principle and method of operation of a plate and frame filter press
- production of a suspension
- removal of the filter cake
- insertion of the filter cloth
- fundamentals of cake filtration
 - ▶ Darcy's equation
- variation in time of filtrate quantity and solid concentration in filtrate
- mass of filter cake dependent on filtrate quantity

CE 287

Plate and frame filter press



1 switch box with controls, 2 suspension tank, 3 filtrate tank outlet and overflow, 4 filtrate tank, 5 spindle, 6 plate and frame filter press

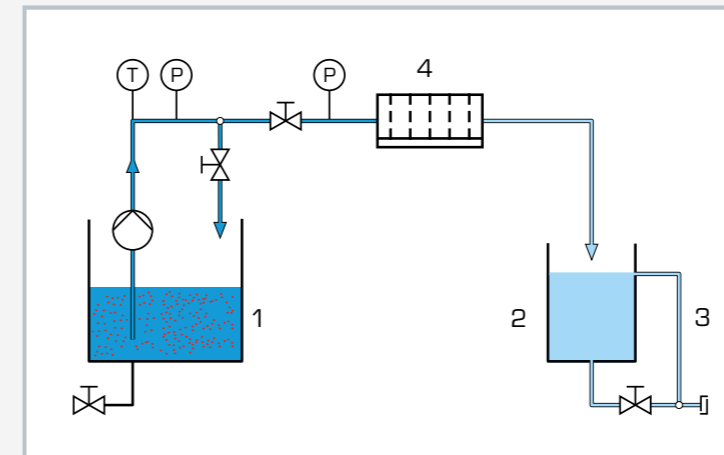

1 tank with pump, 2 filtrate tank, 3 overflow, 4 plate and frame filter press; T temperature, P pressure

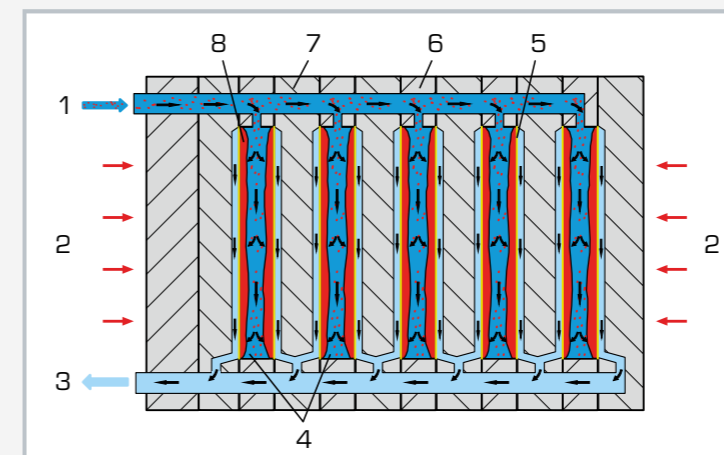

Fundamental principle of a plate and frame filter press: 1 suspension inlet, 2 press forces, 3 filtrate outlet, 4 separating chambers, 5 filter cloth, 6 filter frame, 7 filter plate, 8 filter cake

Specification

- [1] plate and frame filter press for discontinuous cake filtration
- [2] HDPE tank to produce a suspension
- [3] centrifugal pump to deliver the suspension to the plate and frame filter press
- [4] plate and frame filter press with 10 opening separating chambers for removal of the filter cake
- [5] PMMA tank with level scale for filtrate
- [6] adjustment of suspension flow rate by valve
- [7] thermometer and manometer in inlet
- [8] battery-operated opacimeter to measure the solid concentration in the filtrate

Technical data

Plate and frame filter press

- filter area: approx. 0,72m²
- working pressure: approx. 0,4...2,5bar

Centrifugal pump (submersible pump)

- max. flow rate: 4,5m³/h
- max. head: 45m

Tanks

- suspension tank: 200L
- filtrate: 20L

Measuring ranges

- pressure: 0...4bar
- temperature: 0...60°C
- opacity: 0...50,ONTU

230V, 50Hz, 1 phase
230V, 60Hz, 1 phase
120V, 60Hz, 1 phase
UL/CSA optional
LxWxH: 1900x800x1900mm
Weight: approx. 208kg

Required for operation

water connection, drain

Scope of delivery

- 1 trainer
- 1 opacimeter
- 1 packing unit of diatomite (20kg)
- 1 set of accessories
- 1 set of instructional material

CE 283
Drum cell filter**Learning objectives/experiments**

- learning the basic principle and method of operation of a drum cell filter
- fundamentals of cake filtration
- variation in time of filtrate quantity, filter cake mass and thickness
- filter cake mass and thickness dependent on filtrate quantity, negative pressure and drum speed

Description

- separation of solids from suspensions
- continuous removal of filter cake
- practical experiments on a laboratory scale

Drum cell filters can be used to separate solids continuously from suspensions.

The suspension unit produces a suspension of diatomite and water. A pump conveys the suspension into the suspension tank of the drum cell filter. A stirrer keeps the solid particles in the suspension suspended. Part of the rotating drum dips into the suspension. The jacket of the drum is perforated and covered over with a filter cloth. The drum is divided into cells. Each cell is joined by a hollow shaft to a vacuum line.

The vacuum sucks filtrate through the filter cloth into the drum. From there it is carried in a collector tank which is under vacuum. The solid is separated off at the filter cloth. Consequently, a filter cake which steadily grows in the direction of rotation is created on the immersed part of the drum.

When the filter cake is drawn out of the suspension by the rotating motion, it is drained of water by the applied vacuum. A scraper scrapes the filter cake off of the drum before the drum dips back into the suspension. Compressed air can also be used to remove the filter cake. The filter cake drops into a collector tank.

The flow rate of the supplied suspension is adjusted on the suspension unit. The level in the suspension tank of the drum cell filter can be adjusted by way of an adjustable overflow. The applied negative pressure is indicated by a manometer on the vacuum tank. The rotation speed of the drum is infinitely variable.

Compressed air and vacuum connections are required to operate the trainer.

CE 283
Drum cell filter

1 filter cake collector tank, 2 balance, 3 suspension storage tank, 4 filtrate vacuum tank, 5 overflow/outlet, 6 drum cell filter, 7 vacuum supply, 8 stirrer

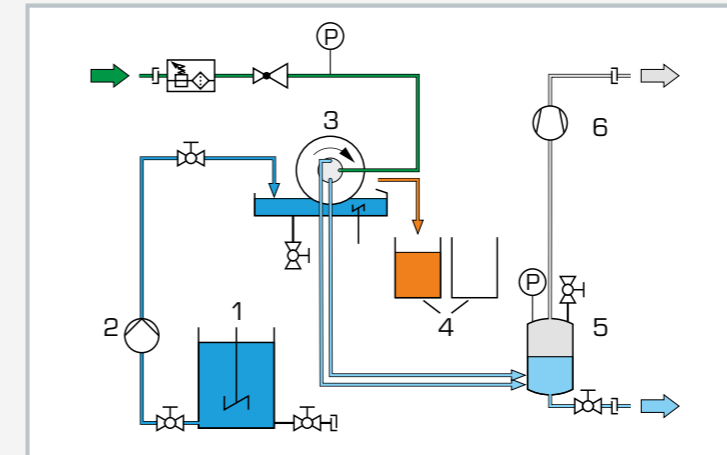

1 suspension storage tank, 2 suspension pump, 3 drum cell filter, 4 filter cake collector tank, 5 filtrate vacuum tank, 6 air suction fan; P pressure; light blue: filtrate, dark blue: suspension, orange: filter cake, grey: vacuum, green: compressed air

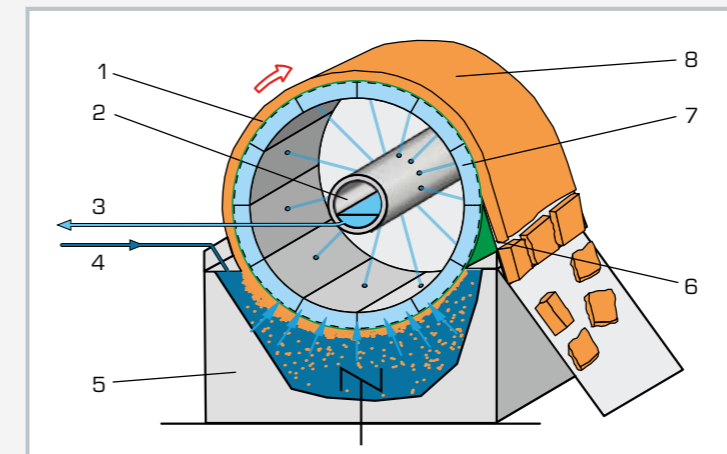

Fundamental principle of a drum cell filter: 1 perforated drum with filter cloth, 2 hollow shaft, 3 vacuum (filtrate), 4 suspension inlet, 5 suspension tank, 6 filter cake removal, 7 cell, 8 filter cake

Specification

- [1] continuous cake filtration of suspensions with a drum cell filter
- [2] rotating perforated drum, partially immersed in suspension, with filter cloth
- [3] vacuum inside drum to draw off filtrate and dry filter cake
- [4] continuous removal of filter cake with adjustable scraper or compressed air
- [5] drum speed infinitely variable
- [6] plastic vacuum tank to collect filtrate
- [7] suspension tank with swing stirrer and overflow
- [8] plastic collector tank for filter cake
- [9] production and transport of suspension with integrated suspension unit
- [10] peristaltic pump as suspension pump

Technical data

- Drum cell filter
- filter area: approx. 0,1 m²
 - speed: approx. 0,1...2 min⁻¹
 - motor power consumption: approx. 200W
- Swing stirrer
- speed: approx. 15 min⁻¹
 - motor power consumption: approx. 200W
- Suspension pump
- max. flow rate: 160L/h
 - max. pressure: 6bar
- Tanks
- filtrate vacuum tank: approx. 30L
 - 2 filter cake collector tanks: approx. 30L
 - suspension tank: approx. 5,5L, max. 10bar
 - suspension storage tank: approx. 200L
- Stirrer at suspension storage tank
- speed: approx. 600 min⁻¹
 - power consumption: approx. 40W

Measuring ranges

- pressure: 0...1 bar (compressed air)
- vacuum: -1...0 bar

230V, 50Hz, 1 phase
230V, 60Hz, 1 phase; 120V, 60Hz, 1 phase
UL/CSA optional
LxWxH: 2180x790x1900mm
Weight: approx. 285g

Required for operation

water connection, drain
compressed air: 3000L/h, min. 0,3bar

Scope of delivery

- 1 trainer
- 1 set of accessories
- 1 set of instructional material

CE 284

Nutsche vacuum filter



Learning objectives/experiments

- basic principle and method of operation of a Nutsche vacuum filter
- fundamentals of cake filtration: Darcy's equation
- mass and thickness of filter cake dependent on filtrate quantity

Specification

- [1] Nutsche vacuum filter for discontinuous cake filtration
- [2] open 2-part vessel with flange and recessed sieve base
- [3] bottom section to draw in and collect filtrate
- [4] top section with inserted filter bag to form filter cake
- [5] polyester filter bag
- [6] manometer to indicate negative pressure in bottom section
- [7] 2 sight glasses to observe level in bottom section
- [8] production and transport of suspension with suspension production unit CE 285

Technical data

Vessel

- inner diameter: approx. 300mm
- capacity: approx. 55L
- permissible pressure: -1bar
- material: stainless steel

Manometer

- Ø 160mm

Measuring ranges

- pressure: -1...0bar

LxWxH: 600x900x1900mm

Weight: approx. 100kg

Required for operation

water connection, drain; vacuum connection (200L/min, 200mbar abs.)

Scope of delivery

- 1 trainer
- 1 set of accessories
- 1 set of instructional material

Description

■ cake filtration with a Nutsche vacuum filter

Nutsche filters are used for discontinuous cake filtration of suspensions with high solid concentrations. The suspension production unit CE 285 produces a suspension of diatomite and water and delivers it from above into the Nutsche filter. A filter bag is inserted in the Nutsche filter. A growing filter cake accumulates in the filter bag made from the separated solid material. The vacuum in the bottom section of the Nutsche filter draws filtrate through the filter cake and the filter bag.

It is collected in the bottom section. After filtering, the filter cake obtained is washed with a washing liquid (water) and is dried by the applied vacuum before being removed.

CE 286

Nutsche pressure filter



Learning objectives/experiments

- basic principle and method of operation of a Nutsche pressure filter
- fundamentals of cake filtration: Darcy's equation
- mass and thickness of filter cake dependent on filtrate quantity

Specification

- [1] Nutsche pressure filter for discontinuous cake filtration
- [2] enclosed 3-part vessel with 2 flanges and 2 bumped bases
- [3] bottom flange with recessed sieve base and PP filter cloth
- [4] bottom section of vessel to collect filtrate
- [5] centre section to form filter cake
- [6] top section removable to remove filter cake
- [7] maintenance and pressure control unit to adjust positive pressure in centre and top section
- [8] 2 manometers to indicate pressure upstream and downstream of filter
- [9] 2 sight glasses to observe level in bottom section
- [10] production and transport of suspension with suspension production unit CE 285

Technical data

Vessel

- inner diameter: approx. 300mm
- capacity: approx. 75L
- permissible pressure: 0,6bar
- material: stainless steel

Measuring ranges

- manometer:
 - ▶ 2x 0...1bar (Ø 160mm)
 - ▶ 1x 0,2...3bar

LxWxH: 600x900x1900mm

Weight: approx. 120kg

Required for operation

compressed air connection: 3bar, water connection, drain

Scope of delivery

- 1 trainer
- 1 set of accessories
- 1 set of instructional material

Description

■ cake filtration with a Nutsche pressure filter

Nutsche filters are used for discontinuous cake filtration of suspensions with high solid concentrations. The suspension production unit CE 285 produces a suspension of diatomite and water and delivers it from above into the Nutsche filter. In the bottom flange of the Nutsche filter is a recessed sieve base with a filter cloth. A growing filter cake accumulates on the filter cloth made from the separated solid material. The applied positive pressure in the top section of the Nutsche filter pushes the filtrate through the filter cake and the filter cloth.

It is collected in the bottom section of the tank. After filtering, the filter cake obtained is washed with a washing liquid (water) and is then dried by an air flow.

CE 285

Suspension production unit



Specification

- [1] supply unit to produce and deliver suspensions for experimental filtration units
- [2] stirred tank with lid and stirring machine to prepare a suspension
- [3] eccentric screw pump, with pressure cut-out switch, dry-running protection and adjustable speed, to deliver the suspension

Technical data

Tank: 200L, stainless steel
Stirring machine
 ■ power consumption: 180W
 ■ speed: 1000min⁻¹ (constant)

Pump
 ■ max. pressure: approx. 5bar
 ■ max. flow rate: approx. 300L/h

Measuring ranges
 ■ manometer: 0...10bar

400V, 50Hz, 3 phases
 400V, 60Hz, 3 phases
 230V, 60Hz, 3 phases
 UL/CSA optional
 LxWxH: 1850x850x1450mm
 Weight: approx. 250kg

Required for operation

water connection, drain

Scope of delivery

- 1 suspension production unit
- 1 packing unit of diatomite
- 1 set of hoses
- 1 set of instructional material

Description

■ supply unit for experimental filtration units CE 284, CE 286

CE 285 provides the experimental filtration units with a suspension of diatomite and water (recommended). The suspension is prepared in the stirred tank. The stirrer ensures that the solid remains suspended and does not settle. An eccentric screw pump delivers the suspension to the connected experimental unit.

The pump rotor is made of stainless steel. It runs inside an elastomer housing. A manometer indicates the pressure. A pressure cut-out switch stops the pump if the pressure is too high. A temperature transducer protects the pump from running dry.

The speed of the pump can be adjusted on a potentiometer. The stirred tank features a level indicator and three flow impeders. All necessary connecting elements are supplied to connect the supply unit to the relevant experimental filtration unit.

Data acquisition and visualisation



Optimal evaluation and analysis of conducted experiments

The GUNT software always has comprehensive online help explaining the functions and application.

The GUNT software is developed and maintained in-house by a group of experienced engineers.

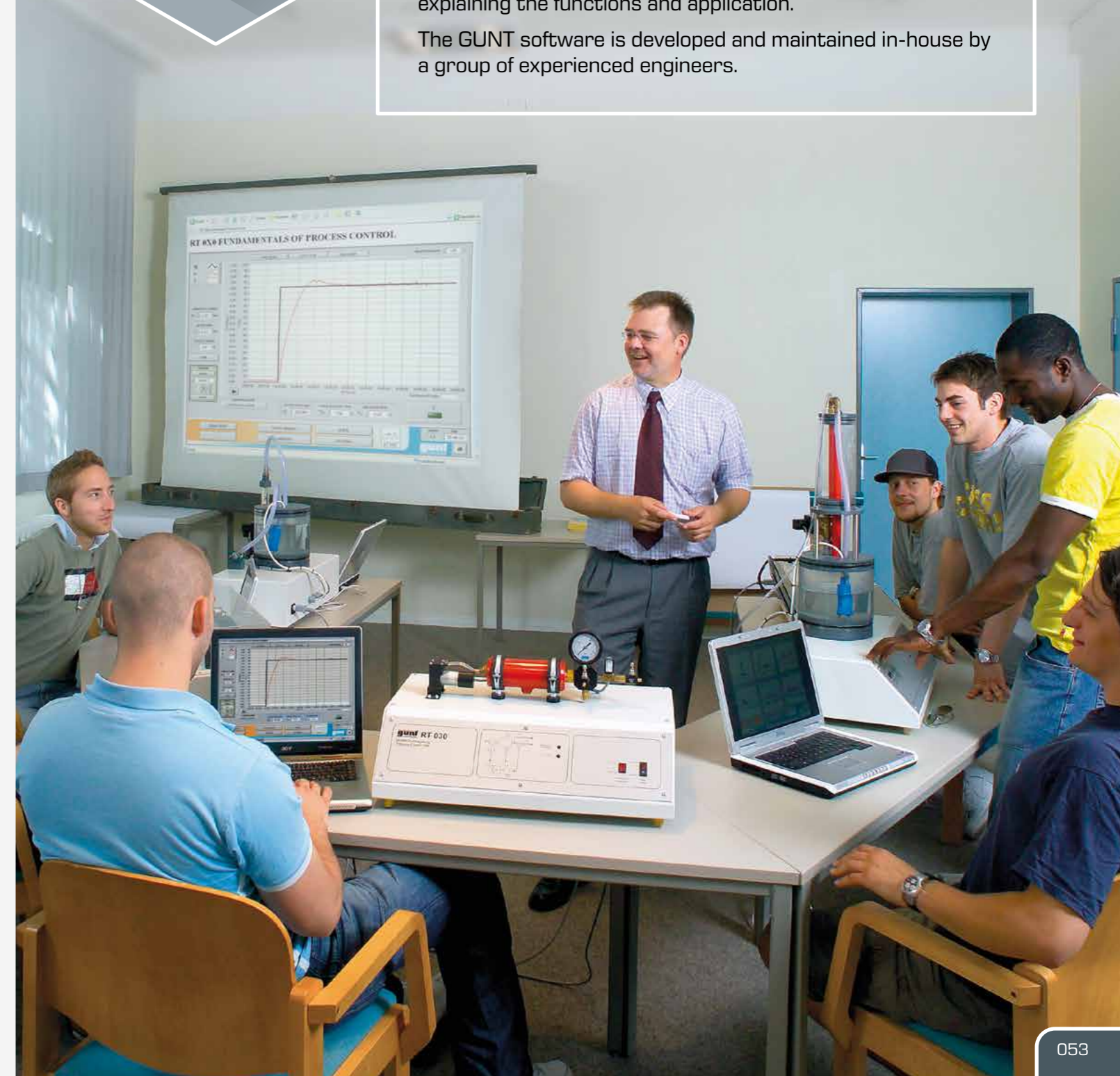

Overview

CE 579 Depth filtration

Depth filtration: indispensable in water treatment

Depth filtration is an important and frequently used process step in water treatment. Exact knowledge of the principle of operation and the characteristics of this process are an indispensable component in the education of budding engineers and specialist technicians.

The educational focus of this trainer is the investigation of the pressure conditions. In order to measure the pressures, the filter is fitted with a differential pressure measurement and a number of individual measuring points along the filter bed.

These measurement points can be connected to a manometer panel, enabling you to very accurately measure the pressure conditions in the filter bed. By using a transparent filter tube, you can also observe the increased loading of the filter bed visually. The filter can be backflushed if necessary.

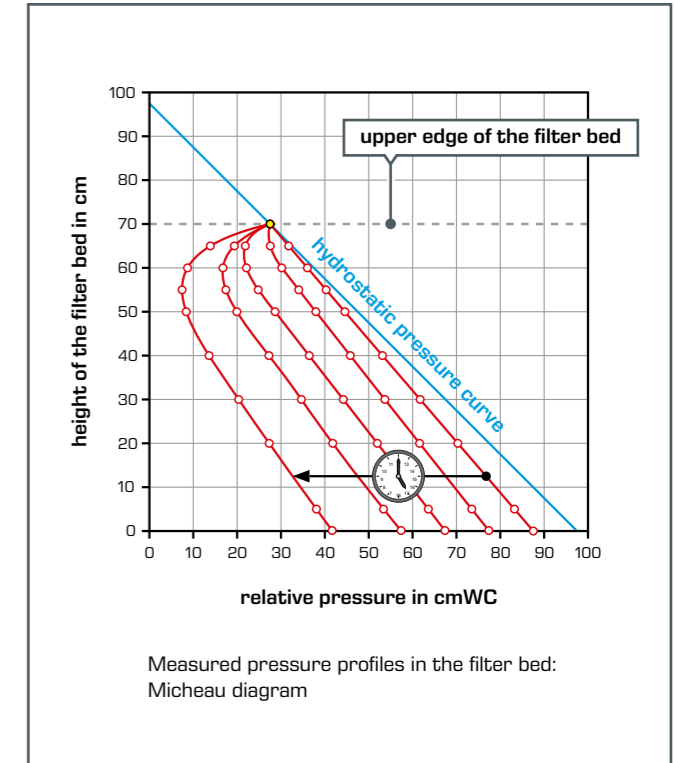
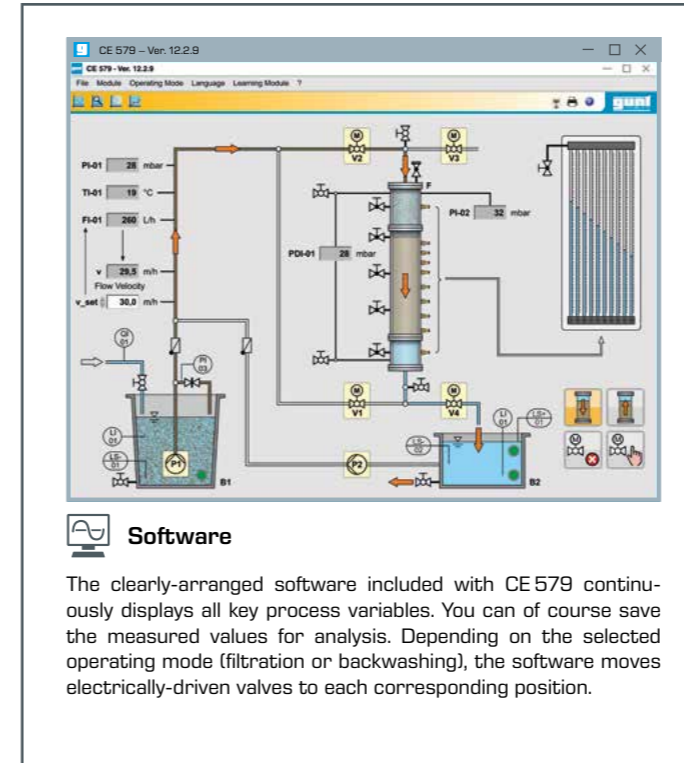

Electrically-driven ball valve



Frequency converters for controlling the pumps



Connections on the manometer panel for measuring the pressure in the filter bed

Learning objectives

- pressure conditions in a filter
- factors influencing the pressure loss (Darcy's law)
 - ▶ flow rate
 - ▶ height of the filter bed
 - ▶ permeability of the filter bed
- determine the pressure in the filter bed (Micheau diagram)
- backwash of filters
 - ▶ observe the fluidisation process
 - ▶ determine the expansion of the filter bed
 - ▶ determine the required flow velocity (fluidisation velocity)

About the product:



CE 579

Depth filtration



The illustration shows: trainer (left) and supply unit (right).

Description

- filtration and backwash
- pressure conditions in a filter
- software for control and data acquisition

Depth filtration is a key unit operation in water treatment. CE 579 enables this process to be demonstrated.

Raw water contaminated with solids is pumped from above into a filter. The solids are captured and retained as the raw water flows through the filter bed. The water itself passes through the filter bed and emerges at the bottom end of the filter. The treated water (filtrate) flows into a tank. Over time, more and more solids are deposited in the filter bed which increases its flow resistance. This process is detectable by the increasing pressure loss between the filter inlet and outlet. The flow through the filter decreases. Backwashing with treated water cleans the filter bed and reduces the pressure loss again.

The filter is equipped with a differential pressure gauge. There are also several pressure measuring points along the filter bed. The pressures are transmitted to tube manometers via hoses and displayed there as water columns. This can be used to plot Micheau diagrams. The flow rate, temperature, differential pressure and system pressure are measured. The flow velocity in the filter bed can be adjusted. Samples can be taken at all relevant points. The height of the filter bed can be read on a scale.

A software program is provided to control the operating states and measure data. A process schematic shows the current operating states of the individual components and the measured data. E.g. diatomite can be used to produce the raw water.

Learning objectives/experiments

- pressure conditions in a filter
- factors influencing the pressure loss (Darcy's law)
 - ▶ flow rate
 - ▶ height of the filter bed
 - ▶ permeability of the filter bed
- determine the pressure in the filter bed (Micheau diagram)
- backwash of filters
 - ▶ observe the fluidisation process
 - ▶ determine the expansion of the filter bed
 - ▶ determine the required flow velocity (fluidisation velocity)

CE 579

Depth filtration

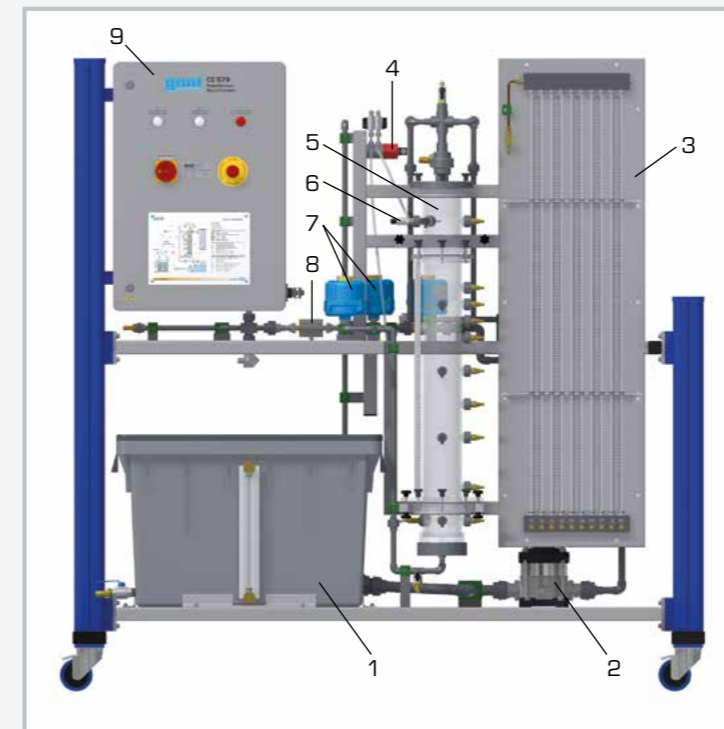

1 treated water tank, 2 backwash pump, 3 manometer panel, 4 differential pressure sensor, 5 filter, 6 system pressure sensor, 7 ball valve with motor, 8 flow rate sensor, 9 switch cabinet

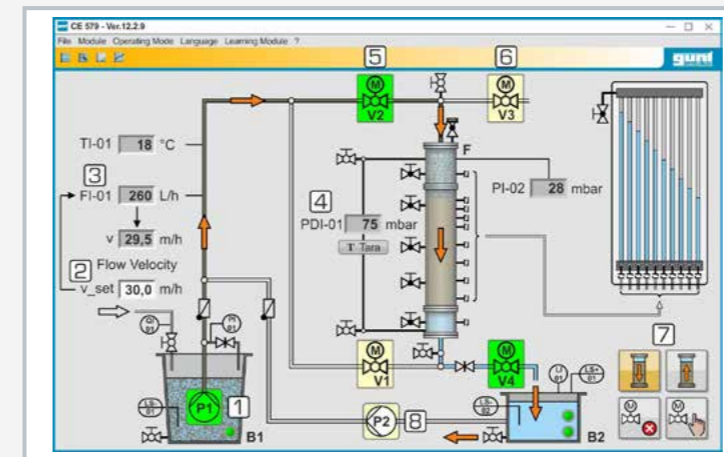

Software of CE 579 (operating state: filtration)

1 raw water pump (in operation), 2 setting the flow velocity, 3 flow rate, 4 differential pressure, 5 ball valve with motor (open), 6 ball valve with motor (closed), 7 adjustment of the ball valves with motor, 8 backwash pump (not in operation)

Specification

- [1] depth filtration and backwash
- [2] separate supply unit with tank and pump for raw water
- [3] pump for backwashing the filter
- [4] 10 tube manometers to measure the pressures
- [5] plotting of Micheau diagrams
- [6] electromagnetic flow rate sensor
- [7] 4 ball valves with motor
- [8] measurement of flow rate, differential pressure, system pressure and temperature
- [9] control of flow velocity
- [10] GUNT software with control functions and data acquisition via USB under Windows 8.1, 10

Technical data

Filter

- inside diameter: 106mm
- total height: 1125mm
- max. filter bed height: approx. 700mm

Raw water pump

- max. flow rate: 150L/min
- max. head: 9m

Backwash pump

- max. flow rate: 40L/min
- max. head: 10m

Tanks for raw water and treated water

- capacity: each 180L

Measuring ranges

- flow rate: 0...1300L/h
- pressure: 1x 0...0,6bar, 10x 0...1260mmWC
- differential pressure: -1...1bar
- temperature: 0...100°C
- filter bed height: 0...720mm

230V, 50Hz, 1 phase

230V, 60Hz, 1 phase, 230V, 60Hz, 3 phases

UL/CSA optional

LxWxH: 1900x790x1900mm trainer

LxWxH: 1200x790x1200mm supply unit

Total weight: approx. 370kg

Required for operation

water connection, drain, PC with Windows

Scope of delivery

- 1 trainer
- 1 supply unit
- 1 set of hoses
- 1 packing unit of gravel
- 1 packing unit of diatomite
- 1 sieve with collecting pan
- 5 measuring cups
- 1 GUNT software + USB cable
- 1 set of instructional material

Basic knowledge Comminution

Comminution alters the particle size and shape and the surfaces of solids. Virtually all solids must be comminuted when being mined or processed.

■ Creating intermediate or end products with specific particle sizes

For many processes applied to solids, specific particle sizes are required in order to create a desired product. For example, thermoplastic input products must be delivered in the form of pellets of a specific size. That is the form in which they can best be melted and formed.

■ Enlargement of the surface

Chemical reactions take place more rapidly when the surface areas of the reacting materials are larger. For example, fine milled coal dust burns explosively, while large pieces of coal burn slowly. Likewise, salts are dissolved more quickly in liquids the smaller their particle size.

■ Recovery of usable materials from solid compounds

Waste materials, mineral and plant raw materials consist of different components. In order to expose the usable materials for further processing, the raw materials must be comminuted. The comminution process is often followed by a sorting process to separate out the usable material. A key example is the recovery of iron ores from rock compounds.

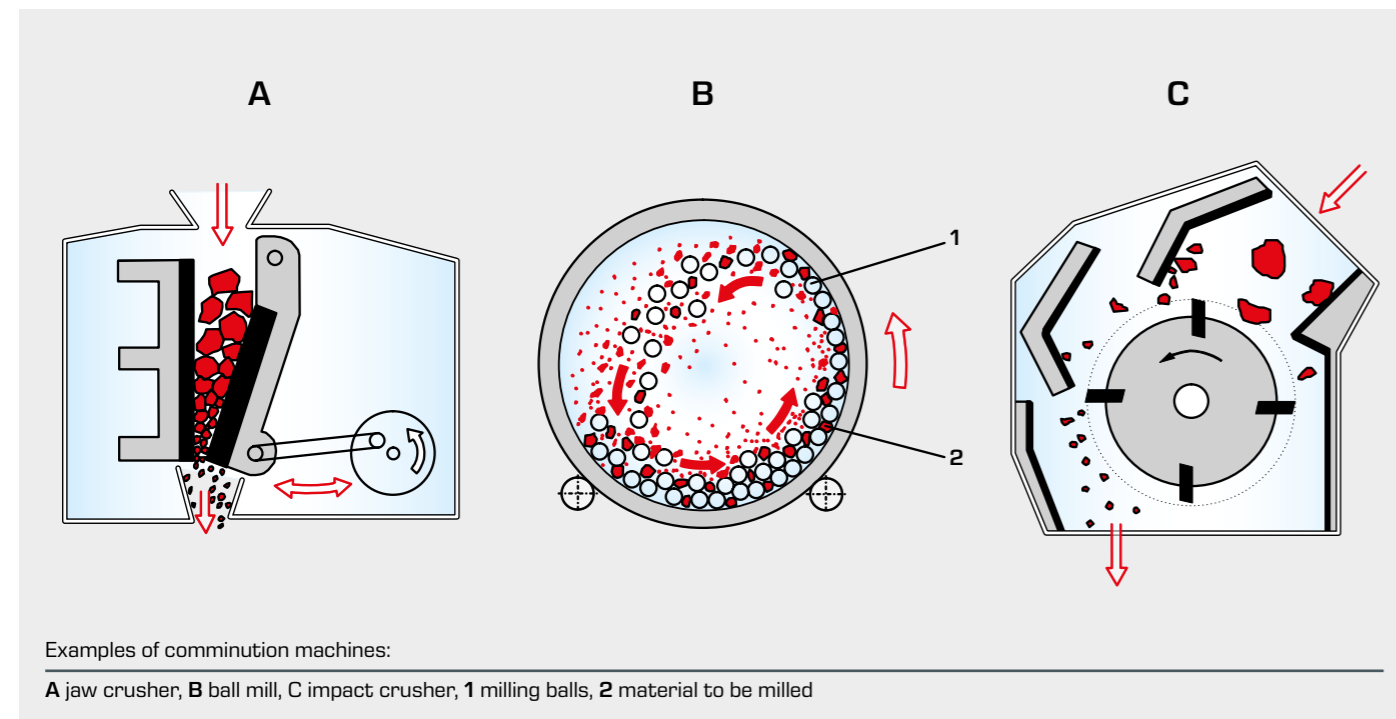

The result of a comminution depends primarily on the method of stress loading applied. In most comminution machines stress is applied between two solid surfaces or by impact:

■ Stress between solid surfaces

The particles are between two surfaces which are moving relative to each other. In the process, the particles are subjected to stress, such as by pressure, shearing, shock impact or cutting. This type of stress loading occurs in the case of jaw crushers and roller or ball mills for example.

■ Impact stress

The particles either impact at high speed against a fixed wall or a tool moves against a free-flying particle. The comminution can also occur when two particles collide.

Typical comminution machines in which the particles are subjected to impact stress are impact crushers and hammer crushers.

CE 245 Ball mill



Learning objectives/experiments

- cascade and cataract motion, critical speed
- theoretical and actual power demand
- degree of comminution dependent on milling time, rotation speed, ball diameter, ball filling, material to be milled

Specification

- [1] comminution of solids with a ball mill
- [2] 2 drums with steel jackets and transparent fronts, 1 steel drum with lifting bars
- [3] 1 drive roller with adjustable speed, 1 loose roller
- [4] axle spacings of rollers adjustable to accommodate different drums
- [5] measurement of power consumption
- [6] milling time programmable by timer

Technical data

2 drums with borosilicate fronts
 ■ Ø 100mm/185mm
 ■ capacity: approx. 1,15L/7,5L

1 drum with lifting bars
 ■ Ø 185mm
 ■ capacity: approx. 7,5L

Drive roller, loose roller
 ■ Ø approx. 50mm

1 set of milling balls
 ■ Ø 5/10/15mm

Measuring ranges

- power consumption: 0...200W
- speed: 0...370min⁻¹

230V, 50Hz, 1 phase
 230V, 60Hz, 1 phase
 120V, 60Hz, 1 phase
 UL/CSA optional
 LxWxH: 600x520x460mm
 Weight: approx. 76kg

Scope of delivery

- 1 ball mill
- 3 milling drums
- 1 set of milling balls
- 1 set of instructional material

Description

■ comminution with a ball mill ■ observation of the milling process

Ball mills are a form of mills with grinding bodies. The drums can be opened at the front and loaded with the material to be milled (limestone is recommended) and the milling balls. The drums are mounted on a drive roller and a loose roller with adjustable spacing between the axles. At low rotation speeds the comminution is effected by the balls rolling over the material (cascade motion). At higher speeds, some balls are lifted up the wall, become detached and drop down onto the material to be milled (cataract motion). Above the critical speed, centrifugal forces ensure that no more comminution takes place. These motion states can be observed through the transparent fronts of the drums.

In order to compare the theoretical power demand with the actual, the power consumption of the drive motor is indicated on a digital display. To assess the success of the comminution, an analytical screening machine (CE 264) is recommended.

Basic knowledge Mixing

Mixing is the opposite of separating. The materials being mixed may be gaseous, liquid or solid. During the mixing of solids, the processed substances are powderous or granular. The objective is usually to create mixtures as homogeneous as possible. During stirring, the continuous phase is liquid. A liquid, gas or solid is mixed into a liquid. Key applications of stirring are:

Example

In the production of tablets, inadequate mixing of the starting substances would result in differing agent compositions in the tablets.

■ Mixing of miscible liquids

The purpose is to balance out differences in concentration and temperature. Moreover, the course of the reaction in the mixture can also be controlled, as the reaction speed is dependent on the mix quality of the reaction partners.

■ Mixing of immiscible liquids (emulsifying)

The liquid phase to be dispersed is in drop-let form in the other liquid phase. This is true in the case of cosmetic creams and lotions for example.

■ Dispersion of soluble solids in liquids

The solid is dispersed in the liquid, and in the process is disintegrated into atoms, molecules or ions. The solid is no longer identifiable as such after being dissolved. Stirring accelerates the dissolution process.

■ Dispersion of an insoluble solid in a liquid (suspension)

The resultant suspensions tend to segregate, meaning that over time the solid particles would sink. Stable suspensions are created only at particle sizes below $1\mu\text{m}$. An example is to be found in the case of paints, in which colour pigment particles are suspended in resins.

■ Gasification of liquids

Gas bubbles in the liquid are finely distributed by means of a perforated plate or other forms of injectors. One application is the precipitation of iron oxides by injection of air in waste water treatment

Stirrers of a wide variety of forms are used, depending on the application. They can be roughly differentiated according to the flow field they create. Accordingly, there are axial, radial and tangential conveying stirrers. Flow impellers or buffers are employed to prevent the entire vessel contents rotating along with the stirrer.

Basic knowledge Agglomeration

Agglomeration is the opposite of comminution. The terms agglomeration, granulation and pelletisation designate the process of particle size enlargement of solids. Powderous fine material is joined together to form larger particle bodies. The particle bodies can be designated as flock, granulate, agglomerate, pellets, briquettes or tablets. The reason for employing an agglomeration process may be to improve the flow behaviour, to enhance mixability, to reduce dust creation, or to alter shape, size, porosity, strength, etc.

A rough distinction can be made between the following agglomeration methods:

■ Constructive agglomeration

Individual, free-moving particles are agglomerated together to form larger bodies, or are agglomerated onto existing particle bodies. Often liquids are used as the binding agent. Constructive agglomeration may occur in fluidised beds.

In rolling agglomeration, large particle bodies are formed by snowballing. The technical application is implemented by way of dish or drum granulators or mixers.

■ Compression agglomeration

An agglomeration is formed from a powderous solid by the action of external compression forces. In tablet production, the powder is compressed in a die with a stamp. Another application is roller pressing, using two smooth rollers (resulting in uneven agglomerations) or rollers with trough-like recesses (resulting in mouldings such as briquettes).

■ Other processes: flocculation to separate suspensions from liquids; sintering.

Different binding mechanisms, with differing adhesive forces, take effect depending on the process (see illustration). A fundamental distinction can be made between mechanisms which involve material binding and those which do not. The most stable are solid archs created by sintering. Solid archs may also be created by other processes if thermo-setting or crystallising binding agents are used.

In constructive agglomeration, adhesion by liquid archs is of primary importance. Depending on the ratio of liquid to solid, the type of liquid and the pore shape and size, adsorption layers permanently bonded to the surface or free-moving liquid archs are produced.

In the case of van der Waals' forces and electrostatic forces, there is no material binding. Van der Waals' forces play a major role in compression agglomeration. Positive bonds occur in fibrous materials such as paper and felt.

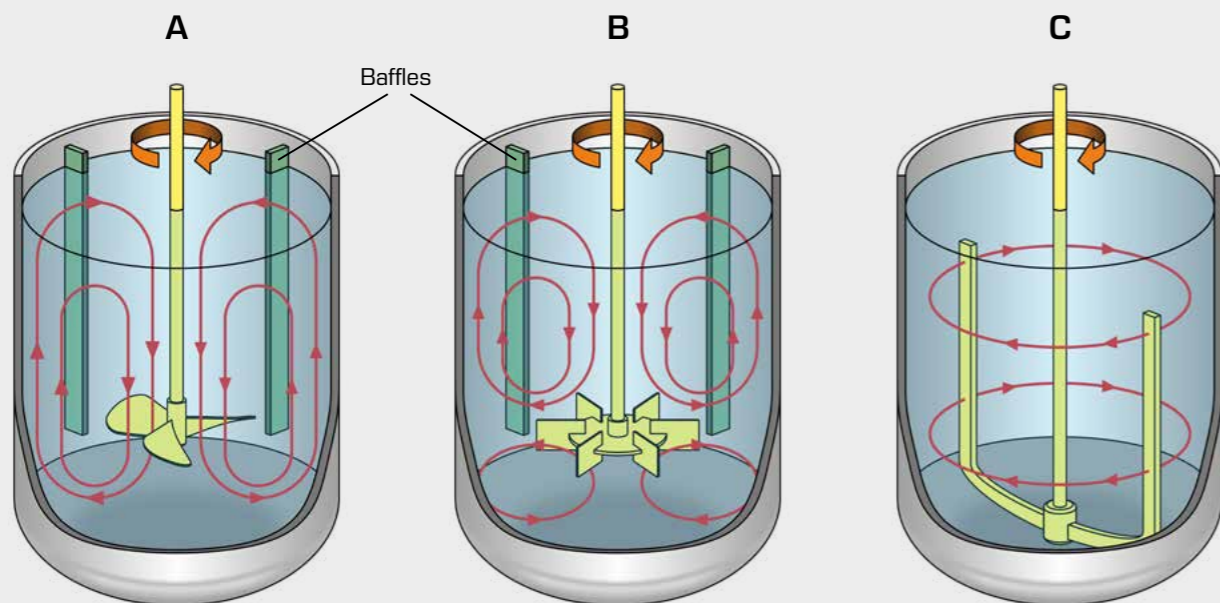

Typical flow fields in stirred tanks:

A propeller stirrer (axial), B Rushton turbine (radial), C anchor stirrer (tangential)

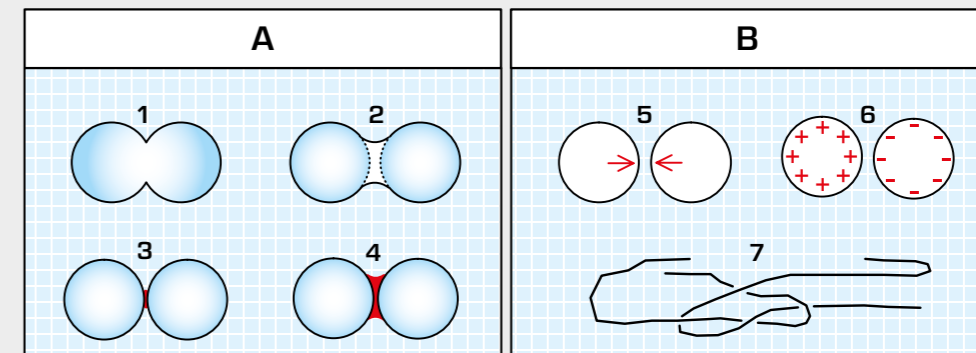

Binding mechanisms in agglomerates:

A mechanisms involving material binding, B mechanisms without material binding;

1 solid arch by sintering, 2 solid arch made of thermo-setting or crystallising binding agent,

3 solid arch with permanently bonded adsorption layer, 4 free-moving liquid arch, 5 attraction by van der Waals' forces,

6 electrostatic attraction, 7 positive bond



CE 320
Stirring**Learning objectives/experiments**

- flow fields of various stirrer types
- power demand, mixing time, mix quality dependent on
 - ▶ stirrer type
 - ▶ speed
 - ▶ materials used (density, viscosity)
 - ▶ insertion of flow impeders
- observation of the suspension state of suspended solids when using different stirrers and at different speeds
- observation of the droplet size of emulsions when using different stirrers and at different speeds

Description

- visualisation of flow fields when using various stirrer types
- high-performance stirring machine with speed control
- determination of mixing time of solutions
- mixing of emulsions and suspensions
- power demand during stirring

During stirring, the continuous phase is liquid. With CE 320, the production of solutions (solid dissolved in liquid), emulsions (mixture of immiscible liquids) and suspensions (insoluble solid in liquid) can be investigated.

Mixing takes place in a tank which is resistant to chemicals and heat-resistant. With the high-performance stirring machine even high-viscosity mixtures can be produced. The speed is adjustable. The torque is indicated on the unit's digital display. This enables the power demand to be determined.

Eleven different, easily interchangeable stirrers are provided. With plastic balls which are dispersed in the fluid it is possible to observe the characteristic flow fields of the different stirrer types.

Flow impeders can be inserted in the tank to investigate their influence on the mixing process. To determine the mixing time and mix quality of solutions, a conductivity meter is available. The device can also be used to measure temperatures.

A removable coiled tube serves as a heat transfer medium. It can be used for heating or cooling with water from the laboratory supply. A valve with precise adjustment is used to adjust the flow rate. This enables the influence of temperature changes on the mixing process to be investigated, e.g. due to fluid viscosity depending on temperature.

CE 320
Stirring

1 stirring machine with speed and torque indicator, 2 turbine stirrer and threaded shaft for stirring heads, 3 stirrer elements, 4 conductivity meter, 5 outlet, 6 flow impeder, 7 coiled tube, 8 shut-off valve for coiled tube



1 propeller stirrers, 2 blade stirrers, 3 threaded shaft for stirring heads, 4 turbine stirrer

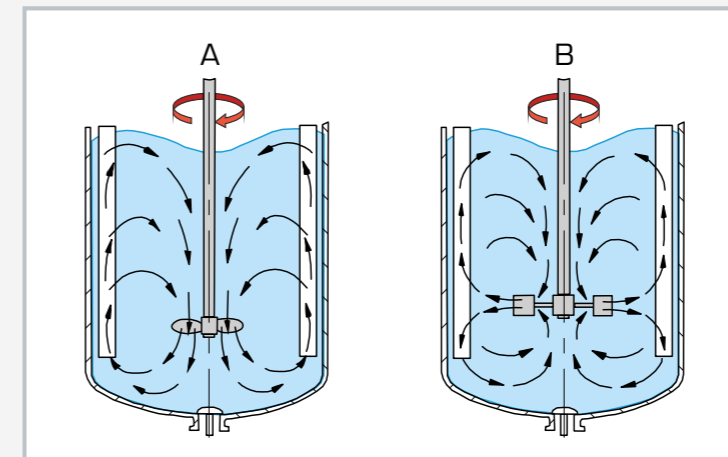

Flow fields in the stirred tank with axial-conveying stirrer (A) and radial-conveying stirrer (B)

Specification

- [1] investigation of mixing processes during stirring
- [2] transparent stirred tank with 4 removable flow impeders
- [3] speed-controlled stirring machine with digital torque indicator
- [4] 11 interchangeable stirrers: axial, radial, tangential-conveying
- [5] removable coiled tube for cooling or heating with external water supply
- [6] portable device for measuring conductivity and temperature

Technical data**Stirred tank**

- nominal capacity: approx. 15L
- material: DURAN glass and PVDF (base)

Stirrer elements

- 7 propeller stirrers
 - ▶ 2x 3 blades, Ø 70mm / 100mm
 - ▶ 1x 4 blades, Ø 70mm
 - ▶ 1x 2 blades, Ø 76mm, left
 - ▶ 1x 2 blades, Ø 76mm, right
 - ▶ 2x 2 blades (angled), Ø 70mm / 100mm
- 3 blade stirrers
 - ▶ 2x Ø 70mm with 3 / 6 holes
 - ▶ 1x Ø 100mm with 10 holes
- 1 turbine stirrer with shaft: Ø 50mm

Coiled tube

- diameter: approx. 140mm
- material: stainless steel

Measuring ranges

- conductivity: 0...200mS/cm
- temperature: -5...100°C
- speed: 50...2000min⁻¹

230V, 50Hz, 1 phase
230V, 60Hz, 1 phase
120V, 60Hz, 1 phase
UL/CSA optional
LxWxH: 1150x825x1950mm
Weight: approx. 135kg

Required for operation

water connection, drain

Scope of delivery

- 1 trainer
- 11 different stirrer elements
- 1 set of accessories
- 1 conductivity meter
- 1 packing unit of plastic balls
- 1 set of instructional material

Overview

CE 322 Rheology and mixing quality in a stirred tank

Mixing processes are largely determined by the flow properties of the substances being mixed. The study of flow properties is called **rheology**. This device allows you to determine all characteristic variables for describing a stirring process. These include mixing characteristics and power curves.

The main component of the device is a high-grade stirring machine with an integrated device for measuring the torque. The stirring process takes place in a circular glass vessel. This provides ideal conditions for observing the stirring process. When using a salt solution, the progress of the stirring process can be reliably recorded by measuring the electrical conductivity. A large selection of different types of stirrer allows a wide range of experiments. The following types of stirrer are included:

- pitched-blade stirrer
- propeller stirrer
- blade stirrer
- turbine stirrer

The stirred tank can be equipped with baffles. The number and position of these baffles can be varied. The viscosity of the medium is critical to the stirring process. Since the viscosity depends on the temperature, a heat exchanger in the form of a coiled tube can be inserted into the stirred tank.

Stirrer types

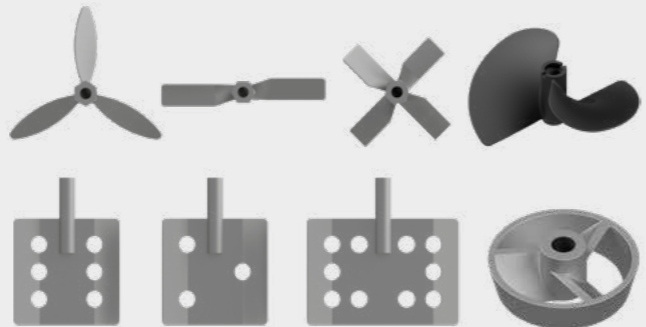

About the product:



- 1 stirred tank
- 2 flow meter
- 3 flow controller
- 4 temperature controller
- 5 digital display for conductivity
- 6 conductivity sensor
- 7 temperature sensor
- 8 stirring machine with torque measurement
- 9 connections for hot and cold water



Stirred tank with built-in heat exchanger

Power curves

A power curve represents the power number N_p as a function of the Reynolds number. Using the power number, it is possible to determine the required power output of a stirring machine, which is essential for the dimensioning of a stirring machine. The profile of a power curve depends on the type of stirrer.

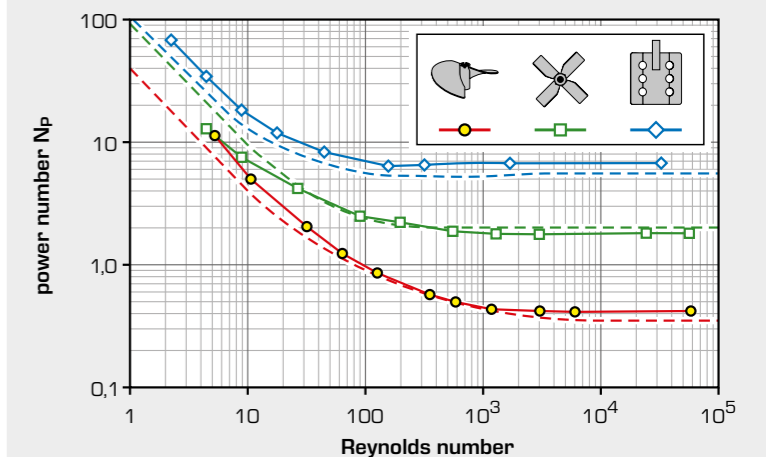

Power curves measured with CE 322 compared to characteristics from technical literature

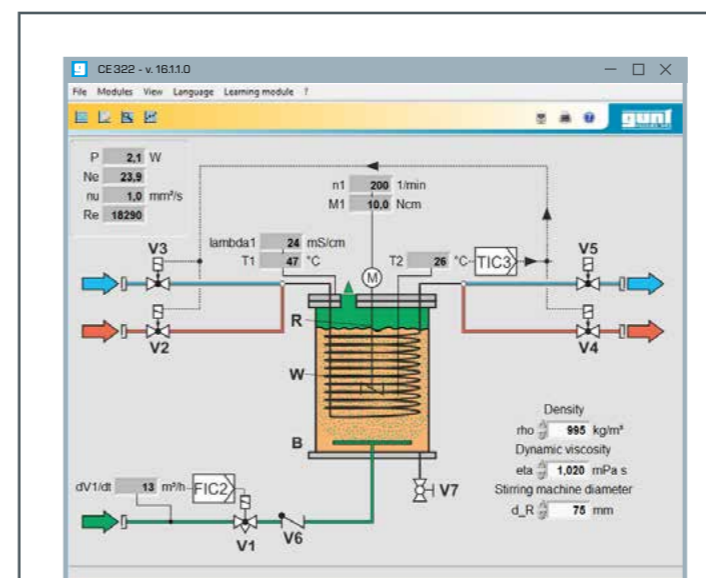

Software of CE 322

Software

The measured values are displayed digitally and can simultaneously be transmitted via USB directly to a PC, where they can be stored using the software included.

Learning objectives

- determination of mixing characteristics
 - ▶ mixing time and degree of mixing
 - ▶ mixing time key figure
- determination of power curves
 - ▶ power demand
 - ▶ power number (Newton number)
- influence of
 - ▶ stirrer type
 - ▶ geometric relationships
 - ▶ speed
 - ▶ substance properties (density, viscosity)
- evaluation of flow state by Reynolds' number (laminar, turbulent)
- mode of action of baffles
- gassing and heat exchange in stirred tanks
- observation of flow fields of different stirrer types for solutions, emulsions and suspensions

CE 322

Rheology and mixing quality in a stirred tank



Learning objectives/experiments

- determination of mixing characteristics
 - ▶ mixing time and degree of mixing
 - ▶ mixing time key figure
- determination of power curves
 - ▶ power demand
 - ▶ power number (Newton number)
- influence of
 - ▶ stirrer type
 - ▶ geometric relationships
 - ▶ speed
 - ▶ substance properties (density, viscosity)
- evaluation of flow state by Reynolds' number (laminar, turbulent)
- mode of action of baffles
- gassing and heat exchange in stirred tanks
- observation of flow fields of different stirrer types for solutions, emulsions and suspensions

Description

■ stirring machine with direct torque measurement to determine power curves

The mixing of solid, liquid and gaseous substances is necessary for the production of many products. The requirements in terms of the stirring machine vary considerably depending on the respective substances, so a large variety of different stirring machines are available.

The continuous phase is liquid during stirring. The CE 322 device can be used to study the production of solutions (solid dissolved in liquid), emulsions (mixture of insoluble liquids) and suspensions (insoluble solid in liquid).

The mixing process takes place in a stirred tank with coiled tube, baffles and gas distributor in the bottom. All installed components are removable.

The stirring machine is located above the stirred tank, can be lowered and is highly effective for the study of viscous substances. The speed can be adjusted. This makes it possible to undertake a detailed investigation of different stirrers and substances, including with gassing (recommendation: water, glycerine, compressed air).

Eleven different exchangeable stirrers are available. Plastic balls are used to visualise the characteristic flow fields of the different stirrer types.

Experiments on the influence of viscosity can be carried out with different substances or different temperatures. The baffles can be used to study and visualise the influence on the mixing process.

Sensors record electrical conductivity and temperature in the stirred tank. The mixing time and degree of mixing of solutions are determined using the electrical conductivities. Torque and speed are used for the power curves. The measured values are displayed digitally and can simultaneously be transmitted via USB directly to a PC, where they can be stored using the software included.

CE 322

Rheology and mixing quality in a stirred tank

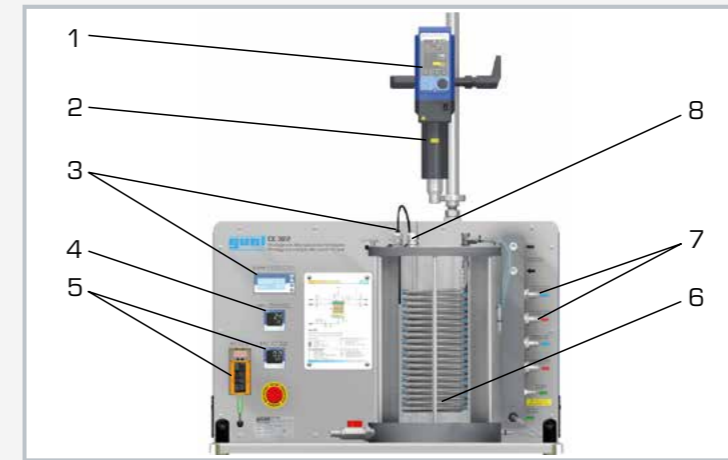

1 stirring machine, 2 torque measurement, 3 electrical conductivity measurement, 4 temperature setting, 5 flow rate setting for gas, 6 coiled tube, 7 connections for hot and cold water and gas, 8 free connections for other measuring instruments

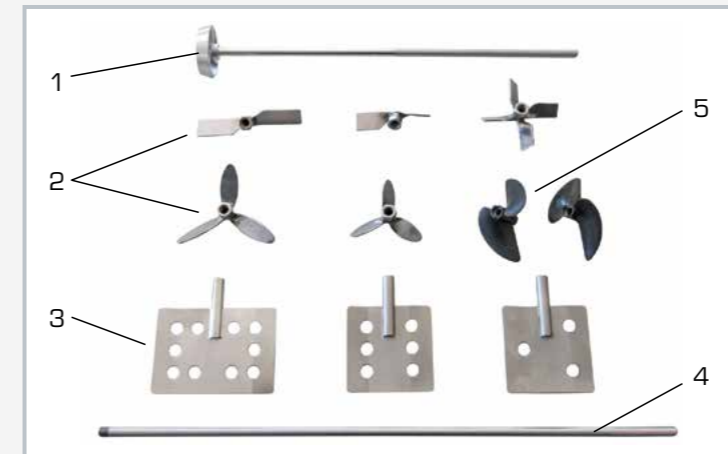

1 turbine stirrer, 2 pitched-blade stirrer, 3 blade stirrer, 4 threaded shaft, 5 propeller stirrer

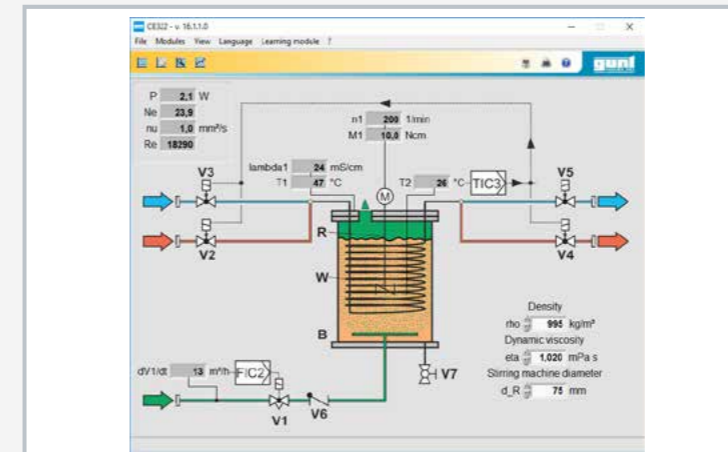

Software screenshot

Specification

- [1] production of solutions, emulsions and suspensions with different viscosities
- [2] stirred tank with coiled tube, baffles and gas distributor in the bottom; removable components
- [3] lowerable, stirring machine with adjustable speed
- [4] 11 stirrers with different geometries
- [5] plastic balls to visualise flow fields
- [6] sensors and digital displays for electrical conductivity, temperature, speed, torque, flow rate
- [7] GUNT software for data acquisition via USB under Windows 10

Technical data

Stirred tank

- volume: approx. 15L
- material: DURAN glass and PVC
- cover with 2 free connections for your own sensors
- gas distributor: holes \varnothing 1,25mm

Stirrers

- 2 propeller stirrers
- 3 blade stirrers
- 5 pitched-blade stirrers
- 1 turbine stirrer

Coiled tube

- length: 9,4m, \varnothing 140mm

Measuring ranges

- conductivity: 0...100mS/cm
- temperature: 0...100°C
- speed: 6...2000min⁻¹
- torque: 0...200Ncm
- flow rate: 1...250L/min

230V, 50Hz, 1 phase

230V, 60Hz, 1 phase; 120V, 60Hz, 1 phase

UL/CSA optional

LxWxH: 800x500x1000mm (experimental unit)

LxWxH: 600x400x150mm (storage system)

Total weight: approx. 80kg

Required for operation

cold and hot water connection, drain
compressed air (0...9m³/h, min. 3bar)
PC with Windows recommended

Scope of delivery

- 1 experimental unit
- 1 GUNT software + USB cable
- 1 storage system
- 1 set of instructional material

CE 255

Rolling agglomeration



Description

- rolling agglomeration with a dish granulator
- strength testing of agglomerates to assess the process
- practical experiments on a laboratory scale

The terms agglomeration, granulation and pelletisation designate the process of particle size enlargement of solids. This trainer was developed in cooperation with the **Department of Mechanical Engineering and Process Engineering at the Niederrhein University of Applied Sciences in Krefeld**.

A powder (fine material) is continuously fed onto an inclined, rotating dish granulator. A pump delivers granulating liquid to a two-component nozzle. The liquid is atomised over the powder by compressed air. Starting from a small number of moistened particles, a rolling motion produces growing numbers of balls (agglomerates). The fine material in the moved layer tends to remain close to the bottom.

It is lifted higher than the forming agglomerates by the rotary motion of the dish. The ball-shaped agglomerates roll along the surface of the layer. When they have attained a certain size, they drop off the rim of the disc. The agglomerates are collected in a tank. Two further tanks are provided for the solid material (for which powdered limestone is recommended) and the granulating liquid (sugar powder diluted in water). The mass flow of solid feed material, the flow rate of the liquid, the speed and the angle of inclination of the disc are adjustable. The compressive strength of the resultant agglomerates can be measured using a laboratory device. To determine these and other key properties of the agglomerates, a drying chamber is also recommended.

Learning objectives/experiments

- learning the basic principle and method of operation of an agglomeration unit
- agglomerate size and strength dependent on
 - ▶ mass flow of solid feed material
 - ▶ flow rate of liquid
 - ▶ ratio of solid to liquid
 - ▶ dish speed
 - ▶ angle of inclination of dish
 - ▶ position of solid and liquid feed
 - ▶ selected solid
 - ▶ selected granulating liquid

CE 255

Rolling agglomeration



1 switch cabinet, 2 solid material metering device, 3 balance, 4 pressure reducing valve, 5 granulating liquid tank, 6 solids tank, 7 agglomerate tank, 8 dish granulator, 9 scraper, 10 two-component nozzle, 11 vibrator, 12 solids silo

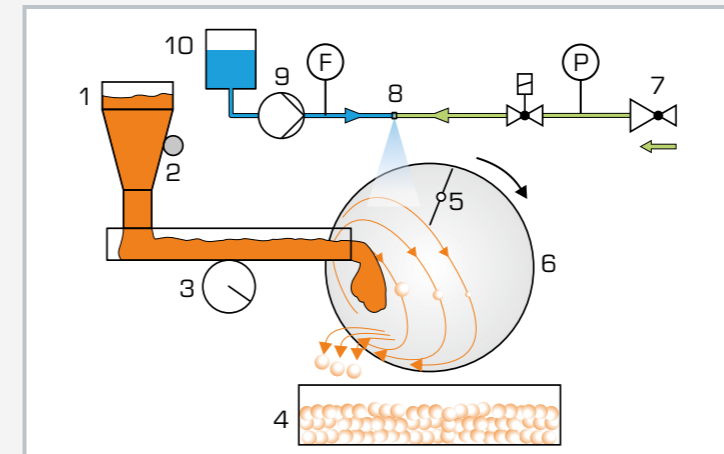

1 solids silo, 2 vibrator, 3 solid material metering device, 4 agglomerate tank, 5 scraper, 6 dish granulator, 7 pressure reducing valve, 8 two-component nozzle, 9 pump, 10 granulating liquid tank; F flow rate, P pressure



Agglomerates

Specification

- [1] rolling agglomeration with a dish granulator
- [2] dish granulator with adjustable speed and angle of inclination
- [3] metering device to adjust the mass flow of solid feed material
- [4] two-component nozzle to atomise the granulating liquid with compressed air
- [5] peristaltic pump to adjust the flow rate of liquid
- [6] air pressure adjustment by pressure reducing valve
- [7] positions of solid and liquid feed adjustable
- [8] tanks for solid, granulating liquid and agglomerates

Technical data

Dish granulator

- Ø: approx. 400mm
- rim height: approx. 100mm
- material: stainless steel

Dish drive motor

- power consumption: approx. 750W
- speed: 20...400min⁻¹

Pump

- max. flow rate: approx. 428mL/min

Tanks

- solids silo: approx. 10L
- granulating liquid: 5L
- agglomerates: 10L
- solids: 40L

Measuring ranges

- flow rate: 0...100mL/min
- pressure: 0...10bar
- speed: 4...70min⁻¹

230V, 50Hz, 1 phase
230V, 60Hz, 1 phase; 120V, 60Hz, 1 phase
UL/CSA optional
LxWxH: 1810x810x1980mm
Weight: approx. 205kg

Required for operation

compressed air connection: min. 3bar

Scope of delivery

- 1 trainer
- 1 balance
- 1 packing units of powdered limestone (50kg)
- 1 set of accessories
- 1 set of instructional material

Basic knowledge

Storage and flow of bulk solids

The term "bulk solids" generally refers to materials in the form of collections of single or individual particles. These particles may be very fine (powder) or coarse. Examples are ores, cement, foodstuffs or chemical products. Bulk solids are stored in tanks, containers or silos, depending on quantity. The storage facilities must be designed such that they neither impair product quality nor cause disturbances to the removal of the bulk solids.

Bulk solids do not behave like Newtonian fluids either when flowing or when at rest in storage. In contrast to Newtonian fluids, bulk solids can also transmit transverse strain when at

rest, and accordingly form surfaces which tend to be stable. Nor are analogies with the behaviour of solids usually possible. For example, in contrast to solids, a bulk solid cannot transmit any significant tensile stresses.

Consequently, in order to describe the behaviour of bulk solids there is a dedicated discipline known as bulk mechanics or powder mechanics, which is founded on that of soil mechanics.

Typical phenomena when bulk solid is flowing out of a hopper or silo are:

- Mass flow

The entire vessel contents are in motion during discharge of the bulk solid. If the area above the hopper is high enough, a uniform sinkage across the cross-section occurs (piston flow).

- Funnel flow

Only a limited zone above the discharge opening, which can widen out upwards in a funnel shape, is in motion during discharge of the bulk solid. At the sides of the flowing bulk so-called dead zones are formed, in which the material is at rest. The material rests in those zones for a long time, and is only discharged towards the end of the emptying process. Moreover, a bulk solid which is not very free-flowing may become compacted in the dead zones to such an extent that it will not flow out by gravity alone.

- Arching

In the case of poor flowing, cohesive bulk solids, a stable arch may form in the discharge hopper causing the material flow to come to a stop.

- Segregation

When filling storage containers, segregation may occur if the particles are of differing size, shape or density. Segregation by its nature reduces product quality.

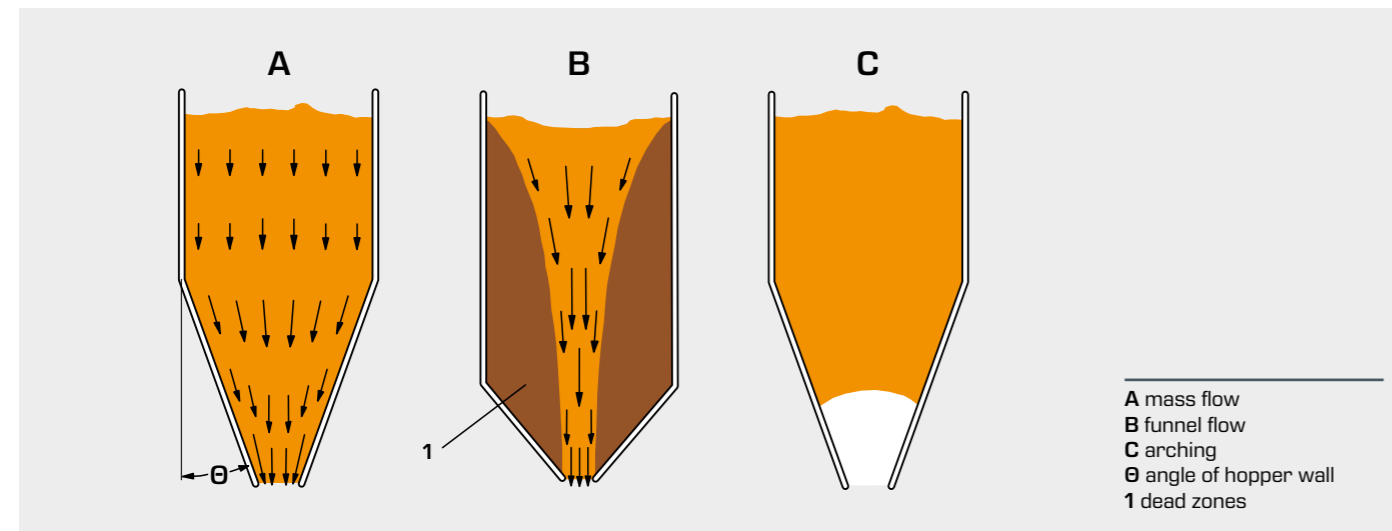

Whether mass or funnel flow is occurring depends on the flow properties of the bulk solid and on the wall material and angle of inclination of the hopper walls. The required angle of the hopper walls can be calculated if the flow properties are known. The

flow properties are measured using shear testers. With these measured values, the minimum size of the discharge opening to avoid arching can also be calculated.

Laboratory and conceptual design from A–Z



Are you planning a new laboratory?

A new specialist room?

An entire department?

Do you want to modernize?

Then take advantage of our know-how and experience! Our engineers design complete laboratories and fit them out. We provide an individual response to your requirements, taking into account the specific local environment:

- room drawings
- supply connections
- equipment lists
- performance specifications, etc.

If you have any questions please contact our sales or customer service, who would be glad to help you.

CE 210

Flow of bulk solids from silos



Description

- adjustable silo geometry
- different types of discharge: mass flow, funnel flow and arching

Silos are used for the large-scale storage of a wide variety of bulk solids. The stored bulk solids are then seamlessly supplied to production processes. To achieve this goal, the silo has to be designed as a mass flow silo.

The CE 210 trainer provides a practical demonstration of the types of discharge from different silos: mass flow, funnel flow and arching. The type of discharge that occurs is dependent on the flow properties of the bulk solids, the silo geometry and the wall material.

The trainer includes two identically shaped silos with transparent front walls and different wall materials. The silos have a wedge-shaped discharge hopper whose inclination and width are adjustable. The trainer has been developed in conjunction with **Professor Dr. Schulze (University of Applied Sciences Braunschweig / Wolfenbüttel)**.

The outflow behaviour is characterised by the measured time, the weight of the bulk solids, the silo geometry and the observed discharge type. The acquired data can also be used to review silo design in practice, for example together with the experimental unit CE 200 Flow properties of bulk solids.

Flour (German type 405) is recommended as additional bulk solid for the experiments with arching.

Learning objectives/experiments

- how wall material and inclination of the hopper walls affect the outflow time
- demonstrate typical discharge types in silos:
 - ▶ mass flow
 - ▶ funnel flow
 - ▶ arching
- how flow properties affect outflow time and flow profiles
- comparison of different bulk solids
- review of the silo design used in CE 200

CE 210

Flow of bulk solids from silos

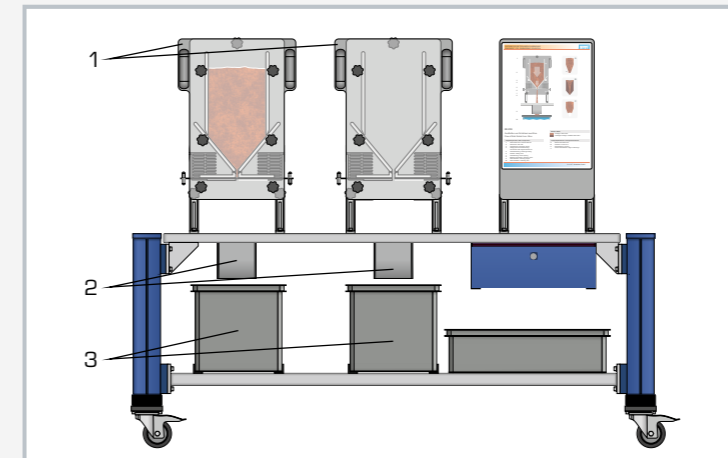

1 silo, 2 hopper, 3 collecting tank

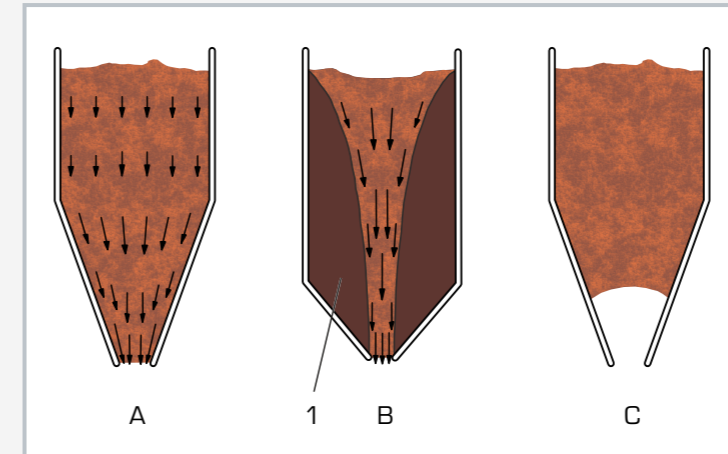

A mass flow: all bulk solids are in motion

B funnel flow: the bulk solids in the centre are in motion, the bulk solids in dead zones (1) are at rest

C arching: the flow of bulk solid comes to a standstill

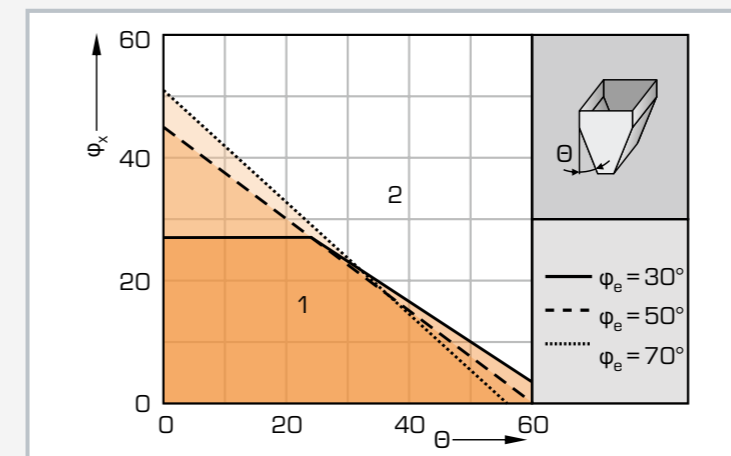

Design diagram of a wedge-shaped silo for different effective friction angle ϕ_e
1 mass flow, 2 funnel flow; ϕ_x wall friction angle, θ inclination of the discharge hopper

Specification

- [1] investigation of the outflow of bulk solids from silos with wedge-shaped discharge hoppers
- [2] demonstration of arching, mass flow and funnel flow with different bulk solids
- [3] two silos with different hopper wall materials
- [4] front walls of the silo made of transparent material
- [5] silos can be removed for cleaning
- [6] angle of the hopper wall adjustable while retaining constant outlet cross-section
- [7] tamper for compacting the bulk solids
- [8] stopwatch for determining outflow times
- [9] practical review of the design results from CE 200

Technical data

- 2 silos with wedge-shaped hopper
- base body cross-section: 200x200mm
 - wide outlet 10...70mm
 - height of silo section: approx 300mm
 - height of hopper: approx. 50...140mm
 - volumes: approx. 14...18L

2 bulk solids

- plastic granulate: 2...5mm
- spelt husks: 5...15mm

Balance

- with tare function
- up to 10kg
- power supply: 230V, 50Hz, 1 phase; 120V, 60Hz, 1 phase; UL/CSA optional

Stopwatch

- 0...10h

LxWxH: 1830x790x1420mm

Weight: approx. 190kg

Required for operation

- 1 other bulk solid (e.g. flour of German type 405)

Scope of delivery

- 1 trainer
- 1 storage system
- 2 collecting tanks with lid
- 1 balance
- 1 packing unit of plastic granulate (20L)
- 1 packing unit of spelt husks (24L)
- 1 set of accessories
- 1 set of instructional material

CE 200

Flow properties of bulk solids



Description

- determination of the flow properties of bulk solids using a ring shear tester for the design of silos
- easy handling based on unlimited shear travel
- professional evaluation software

The flow properties of a powder or bulk solid determine how it behaves during handling. For example, material may flow irregularly out of silos, or the flow of bulk solid may come to a stop. In order to avoid these problems in practice, silos can be designed on the basis of measurements using shear testers, such as the Jenike shear tester or a ring shear tester.

In a ring shear tester, a bulk sample is contained in a ring-shaped shear cell. A normal force is exerted on the sample by way of a lid. A hanger from which a variable weight is suspended generates this normal force. A motor moves the shear cell relative to the lid in order to apply shear to the sample. For compaction (pre-shearing) the sample is subjected to a large normal force. An electronically amplified force transducer measures the shear forces which are then recorded by data acquisition software over time.

After pre-shearing, shearing to failure is executed with a reduced normal force (strength measurement) and likewise recorded by the software. From the shear force characteristics, properties such as the compressive strength and internal friction of the bulk solid can be determined. To determine the density of the bulk solid, the volume of the bulk sample is ascertained by recording the lowering of the lid using a vernier caliper gauge. So as to also take into account the influence of the hopper wall material on the outflow behaviour, a separate measurement is performed with a ring-shaped sample of the wall material.

An evaluation software is available to determine the flow properties from the experimental results. The flow properties identified are used to determine the optimum geometry of a silo's discharge hopper. Trainer CE 210 is provided for practical verification of the design results obtained in terms of mass flow/funnel flow. The ring shear tester and the evaluation software were developed by **Prof. Dr. Schulze (from Braunschweig / Wolfenbüttel University of Applied Sciences)**.

Learning objectives/experiments

- recording the shear force characteristics of bulk solids
- yield locus and wall yield locus design
- determination of flow properties
 - ▶ compressive strength
 - ▶ internal friction
 - ▶ density
 - ▶ wall friction angle
- determination of the optimum hopper geometry of a bulk solids silo

CE 200

Flow properties of bulk solids

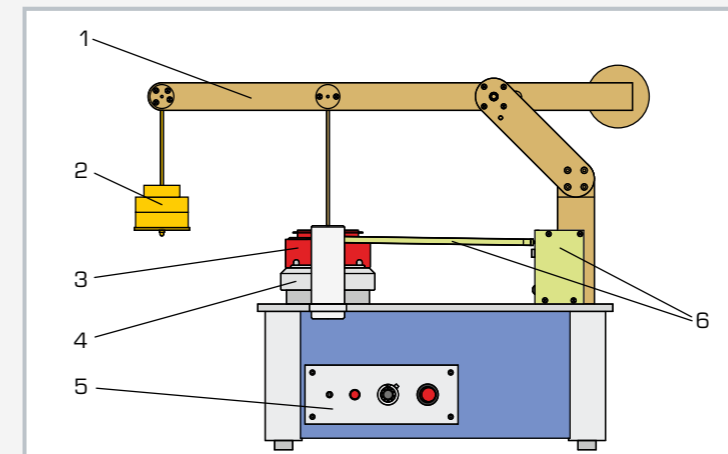

1 loading system for generation of normal force, 2 weights, 3 shear cell, 4 drive unit, 5 controls, 6 force sensor (shear force) with tie rod

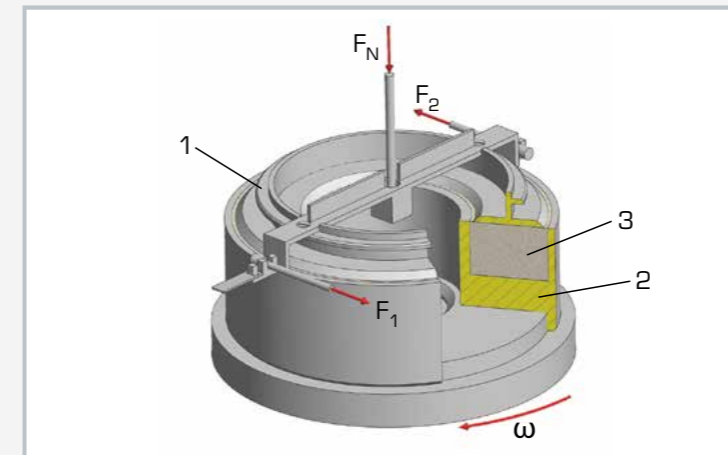

Shear cell for determination of yield loci: 1 lid, 2 shear cell, 3 bulk solid; F_1 , F_2 shear forces, F_N normal force, ω direction of rotation of shear cell

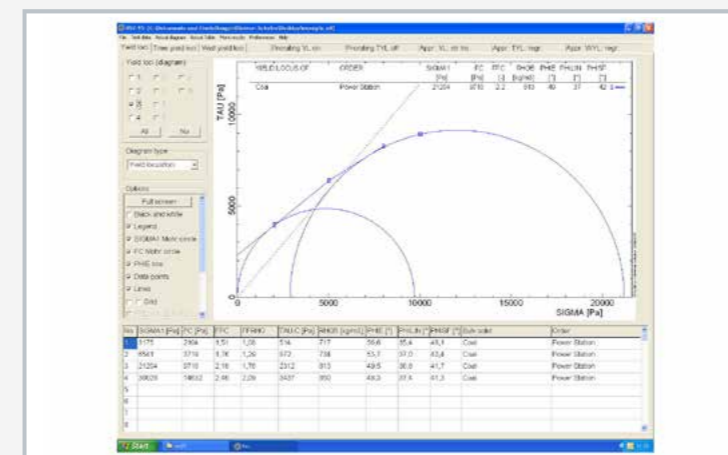

Screenshot from evaluation software: yield locus with Mohr's circles

Specification

- [1] design of bulk solids silos using a ring shear tester
- [2] 1 ring-shaped shear cell to determine yield loci
- [3] 1 ring-shaped shear cell with sample of wall material to determine wall yield loci
- [4] shearing of the bulk solid sample by motor rotation of the shear cell
- [5] vertical loading of the sample via ring-shaped lid with weights
- [6] force sensor to measure the shear forces
- [7] vernier caliper gauge to measure the change in height and density of the bulk sample
- [8] GUNT software for data acquisition via USB under Windows 8.1, 10
- [9] GUNT software to record the shear force characteristics
- [10] evaluation software to determine the relevant bulk solid parameters

Technical data

Shear cell

- sample volume: approx. 70cm³
- material: aluminium

Shear cell with sample of wall material

- sample volume: approx. 15cm³
- material: aluminium

Motor

- power consumption: max. 75W
- speed: 500...3000min⁻¹

1 set of weights

- 4x 500g
- 2x 200g
- 2x 100g
- 2x 50g

Measuring ranges

- force: 0...40N
- balance: 0...1000g

230V, 50Hz, 1 phase
230V, 60Hz, 1 phase; 120V, 60Hz, 1 phase
UL/CSA optional
LxWxH: 400x240x330mm
Weight: approx. 18kg

Required for operation

PC with Windows

Scope of delivery

- 1 experimental unit
- 1 shear cell
- 1 shear cell with sample of wall material
- 1 vernier caliper gauge
- 1 GUNT software + USB cable
- 1 evaluation software
- 1 packing unit of bulk solid
- 1 balance
- 1 set of instructional material

Basic knowledge Fluidised beds

A fluidised bed involves two phases: a solid and a fluid (gas or liquid). If a fluid flows through a resting layer of bulk solid at an adequate velocity (fluidisation velocity), the layer is loosened so that individual solid particles enter a suspended state. This state is termed fluidisation. The fluidised bed created in this way behaves similarly to a liquid in terms of flow and thermodynamics.

If the velocity is excessive, particles are discharged from the fluidised bed. Hydraulic or pneumatic transport begins.

Owing to the large contact surfaces between the solid and fluid, heat and material transport processes between the particles and the fluid, and among the particles themselves, are encouraged.

One application of this is in fluidised bed combustion, where combustion takes place in a fluidised bed made of comminuted fuel and hot combustion air. The fluidised bed principle permits low combustion temperatures. As a result, very low nitrogen oxide emission limits can be achieved.

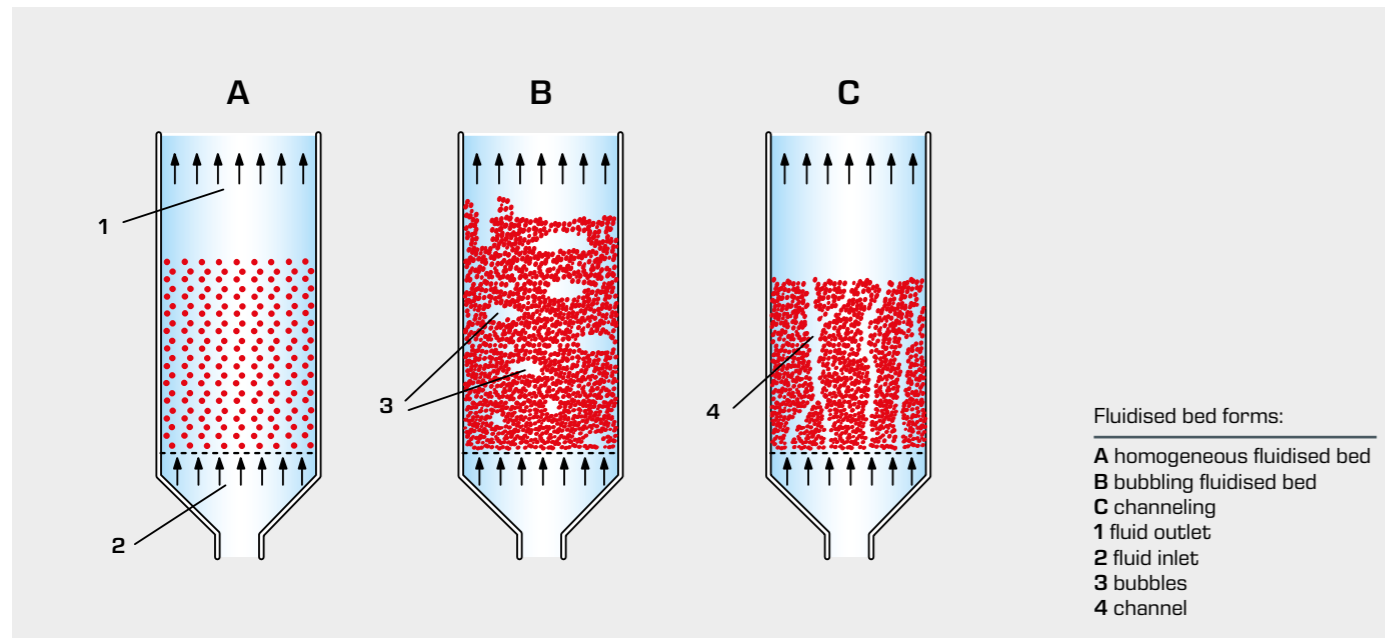

The following forms of fluidised bed may occur:

■ Homogeneous fluidised bed

As the flow velocity of the fluid increases, a uniform volumetric dilation of the fluidised bed occurs. The solid particles are evenly distributed across the entire layer. In reality, behaviour of this kind is to be observed only in liquids when using particles of equal size.

■ Inhomogeneous fluidised bed

Classification or sorting processes take place in the fluidised bed. Specifically heavier particles are enriched in the lower zone. When using gases as the fluid, bubbling almost always occurs in the fluidised bed. The bubbles are free of solids. Smaller bubbles merge on their way to the surface to form larger bubbles. At the surface they burst. The surface of the fluidised bed looks like a boiling liquid.

■ Channeling

If a fine-grained bulk solid is used as the solid, and if the individual particles adhere to each other, formation of a fluidised bed may not occur. Instead, flow channels are created. There is no flow through the surrounding zones. With such solids, a fluidised bed can only be created by additional stirring.

Basic knowledge Pneumatic transport

Pneumatic conveyor systems transport powderous and granular bulk solids by means of a gas flow (mostly air) in pipelines. The bulk solids may be foodstuffs such as grain or pulses for example.

Pneumatic conveyor systems essentially consist of an air compressor, a conveying line and a dust separator (e.g. gas cyclone). Transport may be effected horizontally, vertically, or occasionally inclined.

Typically the conveyor line may be connected to the intake (suction or vacuum) or delivery (positive pressure) side of the air compressor. Combination suction/positive pressure systems also exist. Vacuum conveying systems have a beneficial feature in that the vacuum in the system does not permit any dusty air to leak out. Positive pressure conveying systems enable transport over greater distances and differences in height than vacuum conveyors.

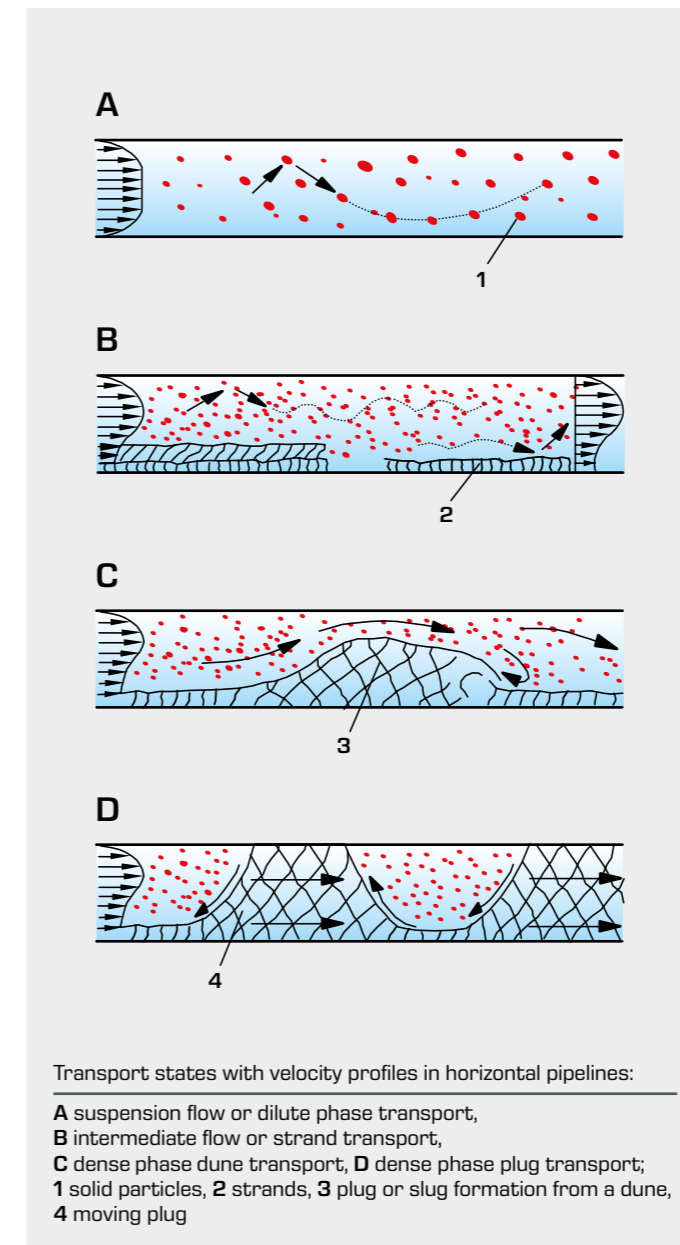

Depending on the velocity and solid content of the airflow, different transport states may occur in **horizontal** pipelines:

■ Suspension flow or dilute phase transport

At high velocities the solid particles move through the line distributed uniformly across the cross-section. Particles impact against each other or against the pipe wall.

■ Intermediate flow or strand transport

If the velocity is reduced while the solid content remains constant, the energy of the flow is no longer sufficient to hold the entire solid mass suspended. Some of the solid particles slide along the bottom of the pipe in the form of strands. The rest are transported in suspension above the strands.

■ Dense phase dune transport

If the velocity is reduced further, the solid particles move like a dune. Particles are moved over the summit of the dune and are deposited on its sheltered side. If the velocity is reduced further, incipient plugs may be formed from the dunes which occupy a major part of the cross-section of the pipe.

■ Dense phase plug transport

At very low velocities the material occupies the entire cross-section of the pipe and plugs are formed. Plugs advance slowly. If the air compressor does not have sufficient pressure reserves, plug transport may quickly lead to blockage of the pipeline.

In **vertical** pipes the same transport states occur in principle, though gravity is more of an influencing factor.

CE 220

Fluidised bed formation



Learning objectives/experiments

- fundamentals of the fluidisation of bulk layers
- observation and comparison of the fluidisation process in water and air
- pressure loss dependent on
 - ▶ flow velocity
 - ▶ type and particle size of the bulk solid
- determination of the fluidisation velocity and comparison with theoretically calculated values (Ergun equation)
- dependency of the height of the fluidised bed on the flow velocity
- verification of Carman-Kozeny equation

Description

- experimental investigation of the fluidisation process
- comparison of fluidised bed formation in gases and liquids
- pressure loss in fixed beds and fluidised beds

If liquids or gases flow through a layer of solid particles and the fixed bed is loosened to such an extent that the solid particles can move freely, the fixed bed is transformed into a fluidised bed. The pressure loss of the fluid that is flowing through can be used to characterise a fluidised bed. Typical areas of application of fluidised beds include the drying of solids or roasting and combustion processes.

The fluidised bed formation in water and air can be observed using CE 220.

The continuous phase (water or air) flows upwards through the fixed, dispersed phase above a porous sintered-metal plate. If the velocity of the fluid is less than the so-called fluidisation velocity, the flow merely passes through the bulk layer without causing the particles to move. This state is referred to as a fixed bed. At higher velocities, the bed is loosened and the particles begin to move. The fixed bed is thereby transformed into a fluidised bed. An increase in the velocity results in a vertical expansion of the fluidised bed. Once the velocity is sufficiently high, the particles are carried out of the fluidised bed.

In practice, the particles are transported in pipes, for example. In CE 220, filters and the sintered-metal plate hold the particles back.

The fluids' currents are read on rotameters. The water flow rate is adjusted via the speed on the pump. The air volume flow can be adjusted via a separate flow control valve. An electronic, hand-held unit for measuring the pressure loss is included in the scope of delivery. The height of the fluidised beds is read on the scales of the tanks.

The tanks are removable, making it easy to change the bulk solid. Glass-shot beads in a range of particle sizes are provided as the bulk solid.

CE 220

Fluidised bed formation



1 water overflow, 2 tank for water, 3 rotameter for water, 4 hand-held measuring unit pressure loss, 5 rotameter for air, 6 tank for air, 7 filter

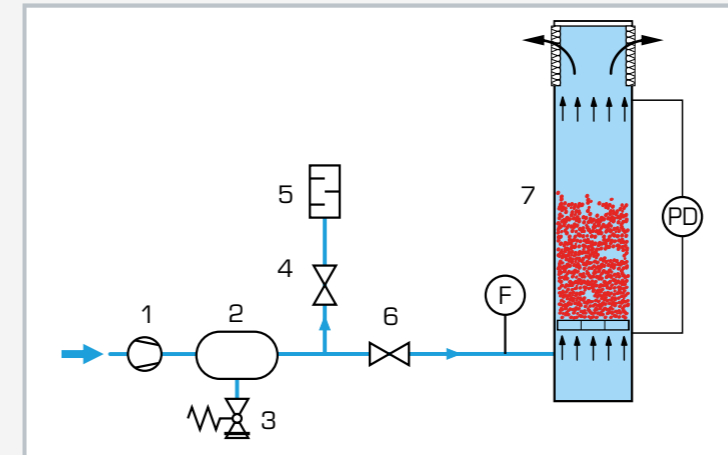

Experimental setup for fluidised bed formation with air
1 diaphragm compressor, 2 compressed air accumulator, 3 safety valve, 4 bypass valve, 5 silencer, 6 needle valve, 7 tank (air);
F flow rate, PD differential pressure

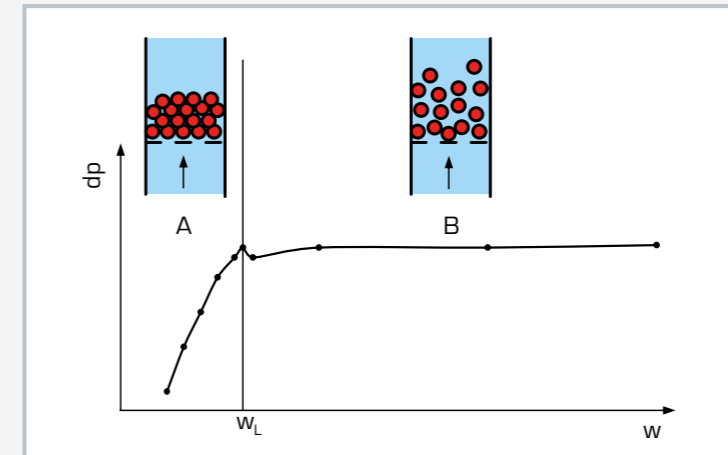

Pressure loss of a fluidised bed with air flowing through
dp pressure loss, w flow velocity, w_L fluidisation velocity,
A fixed bed, B fluidised bed

Specification

- [1] investigation of the transformation from fixed bed to fluidised bed
- [2] experiments with air and water next to each other
- [3] both tanks removable
- [4] scales on the tanks to measure the height of the fluidised bed
- [5] water supply via storage tank with diaphragm pump
- [6] compressed air supply via compressed air accumulator and diaphragm compressor
- [7] volumetric flow rate for air adjustable via valves
- [8] flow rate for water adjustable via speed on the diaphragm pump
- [9] measurement of pressure loss using electronic, hand-held unit

Technical data

2 tanks

- length: 380mm
- inside diameter: 44mm
- graduation: 1mm
- material: PMMA

diaphragm pump (water)

- max. flow rate: 1,7L/min
- max. head: 70m

diaphragm compressor (air)

- max. volumetric flow rate: 39L/min
- max. pressure: 2bar

water storage tank: approx. 5,5L

compressed air accumulator: 2L

Measuring ranges

- pressure: 0...200mmWC
- flow rate: 0,2...1,6L/min (water)
- volumetric flow rate: 4...33NL/min (air)
- height: 25...370mm

230V, 50Hz, 1 phase

230V, 60Hz, 1 phase; 120V, 60Hz, 1 phase

UL/CSA optional

LxWxH: 750x610x1010mm

Weight: approx. 80kg

Scope of delivery

- 1 experimental unit
- 1 packing unit of glass-shot beads (180...300 μ m; 1kg)
- 1 packing unit of glass-shot beads (420...590 μ m; 1kg)
- 1 set of instructional material

CE 222

Comparison of fluidised beds



Learning objectives/experiments

- fundamentals of the fluidisation of fixed beds
- fluidised bed formation with air
- pressure losses as a function of
 - ▶ empty pipe velocity
 - ▶ particle size
 - ▶ particle density
 - ▶ fixed bed height
- determination of fluidisation velocity and comparison with theoretically calculated values (Ergun equation)
- how fluidised bed height depends on flow velocity
- verification of the Carman-Kozeny equation

Description

- two transparent columns with different diameters for observation of fluidised bed formation in gases
- pressure loss in fixed and fluidised beds

Bulk layers can transition from a fixed bed into a fluidised bed when gases flow through them. The fields of application for fluidised beds include, for example, drying solids, in furnaces and coating particles.

This trainer was developed in cooperation with the **University of Greenwich, UK**. The CE 222 unit contains two transparent columns with different diameters to form a fluidised bed using compressed air as the gas. A scale on the columns indicates the height of the fixed or fluidised bed. Solenoid valves supply compressed air to the column being studied.

One column can be operated at a time. The columns can be removed to allow the fixed bed to be changed. Glass beads in different particle sizes are supplied as the packing.

At the start of the experiments, a fixed bed rests on a sinter plate at the bottom of the column. Compressed air flows upwards through the column and exits at the air filter. If the velocity of the air is lower than the fluidisation velocity, the flow simply passes through the fixed bed. At higher velocities, the fixed bed is loosened to such an extent that the particles are put into a state of suspension. The fixed bed transitions into a fluidised bed. If the velocity is further increased, particles are discharged from the fluidised bed (transportation). The air filter at the head of the column retains these particles.

The volumetric flow rate of the compressed air is measured and controlled using two measuring ranges. Both columns are equipped with measuring points, to which differential pressure sensors can be connected. These record the pressure loss in the fixed and fluidised bed. The measured values are transmitted directly to a PC via USB where they can be displayed using the software included. The trainer is operated using the Gunt software. An external compressed air supply is required for operation.

CE 222

Comparison of fluidised beds



1 column K1 with \varnothing 100mm, 2 column K2 with \varnothing 50mm, 3 differential pressure measuring points of K1, 4 gas supply for K1, 5 gas supply to the trainer, 6 flow measurement for 2 measuring ranges

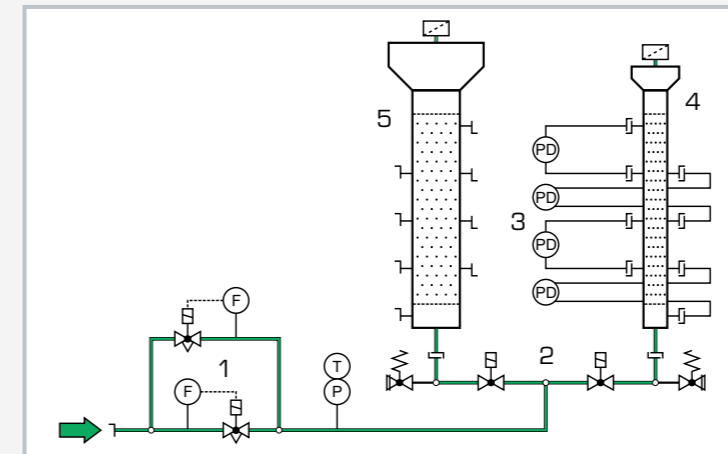

1 flow rate measurement, 2 column changeover, 3 differential pressure measurement, 4 column K2 with \varnothing 50mm, 5 column K1 with \varnothing 100mm

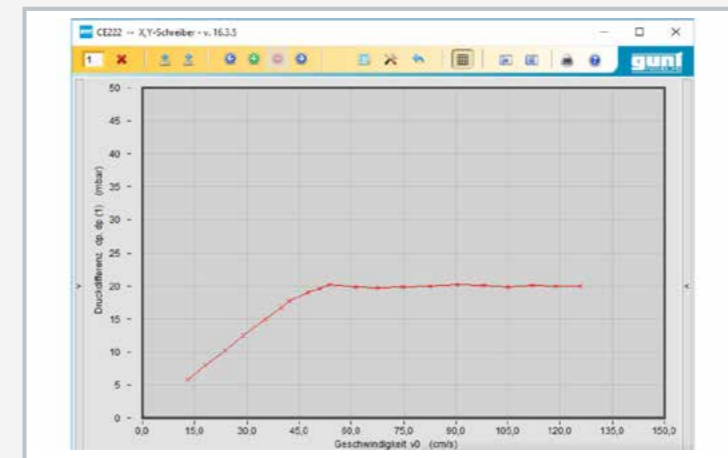

Software screenshot: Measurement results in the X,Y recorder

Specification

- [1] investigation of the fluidised bed formation of solids in gas
- [2] 2 removable, transparent columns with different diameters
- [3] solenoid valves to select the column being studied
- [4] each column has a sinter plate, scale, air filter
- [5] each column has 4 differential pressure measuring points in fixed and fluidised bed to determine the pressure losses
- [6] volumetric flow rate control with 2 measuring ranges
- [7] glass beads in different particle sizes as packing
- [8] GUNT software with control functions and data acquisition via USB under Windows 8.1, 10

Technical data

2 columns

- length: 500mm
- \varnothing 1x 50mm, 1x 100mm
- material: glass
- scale, graduation: 1mm

Measuring ranges

- flow rate: 1x 1,8...18L/min, 1x 15...150L/min
- differential pressure: 4x 0...50mbar
- pressure: 0...2,5bar
- temperature: 0...60°C

230V, 50Hz, 1 phase

230V, 60Hz, 1 phase; 120V, 60Hz, 1 phase

UL/CSA optional

LxWxH: 1400x800x1700mm

Weight: approx. 132kg

Required for operation

compressed air (1,8...150L/min, 5bar)
PC with Windows

Scope of delivery

- 1 trainer
- 1 packing unit of glass beads (180...300 μ m; 2kg)
- 1 packing unit of glass beads (420...590 μ m; 2kg)
- 1 set of accessories
- 1 GUNT software + USB cable
- 1 set of instructional material

CE 250

Pneumatic transport



Learning objectives/experiments

- learning the fundamental principle and method of operation of a pneumatic conveyor system
- observation of different transport states dependent on solid content and air velocity
- determination of the suspension velocity of the solid
- determination of the solid content of the flow
- pressure loss dependent on solid content and air velocity

Description

- pneumatic pressure-lifting of solids in a vertical tube
- transparent tubes and tanks to observe different transport states
- practical experiments on a laboratory scale

Pneumatic conveyors can be used to transport dispersed solids over great distances in pipelines.

The solid is transported out of a feed tank via a vibrating trough into an air flow. An interchangeable injector disperses the solid in the air flow. The air flow transports the solid upwards in the tube. The transport terminates in a collector tank.

Depending on the velocity and solid content of the air flow, different transport states may occur. At high velocities, the solid is dispersed evenly across the cross-section of the tube (dilute phase transport). If the velocity is reduced, strands and balls form on the wall of the tube which then slide down owing to their higher settling velocity. The strands and balls disintegrate again in the air flow and reform. Reducing the velocity to below the settling velocity of the individual particles ultimately results in plug transport. The different transport states can be observed through the transparent tube.

To identify the pressure loss and the flow velocity, measuring points are provided at all relevant positions. The velocity of the air flow is adjusted by a pressure regulator. The solid mass flow can be adjusted by way of the throw of the vibrating trough on a potentiometer. The compressed air has to be provided from the laboratory supply.

Peas or plastic granulate are recommended for use as the solid.

CE 250

Pneumatic transport

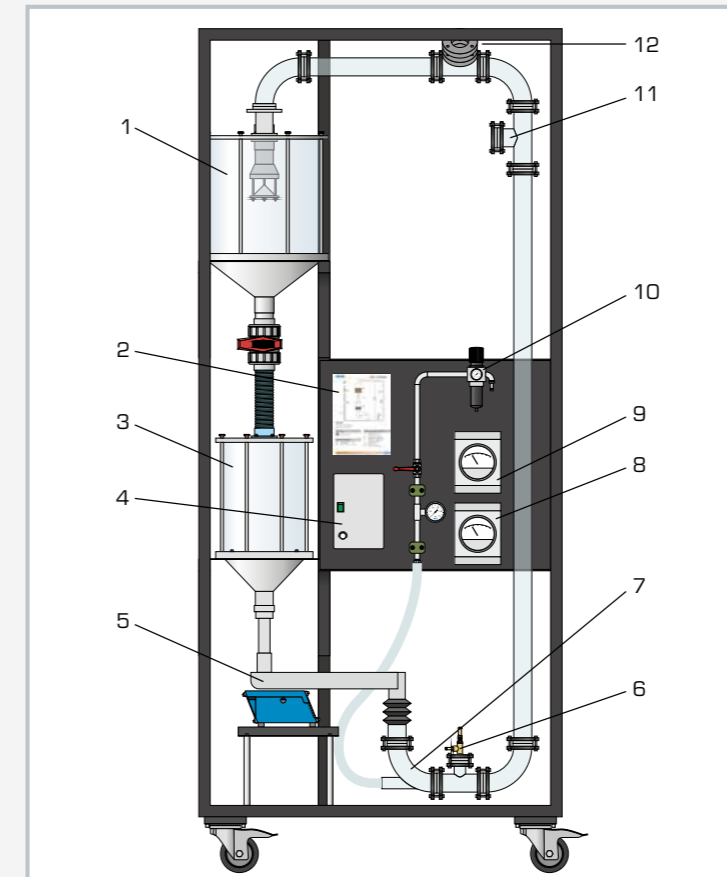

1 collector tank, 2 process schematic, 3 feed tank, 4 vibrating trough controls, 5 vibrating trough, 6 pressure measurement point, 7 injector, 8 differential pressure indicator, 9 velocity indicator, 10 precision pressure regulator, 11 velocity measurement point (Pitot tube), 12 pressure measurement point

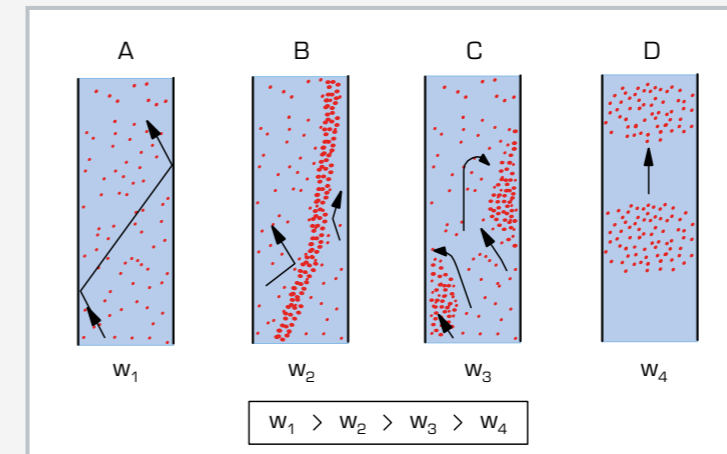

Transport states in vertical transport: A dilute phase transport, B strand transport, C ball transport, D plug transport; w air velocity

Specification

- [1] pneumatic pressure-lifting of solids in a vertical tube
- [2] feed of solid into air flow via vibrating trough with adjustable throw
- [3] 4 interchangeable injectors to disperse the feed material into the air flow
- [4] vertical tube made of glass
- [5] collector and feed tanks made of transparent material (PMMA)
- [6] collector and feed tanks interconnected by tube with plug valve
- [7] precision pressure regulator to adjust input pressure and flow rate
- [8] measuring points for pressure loss and flow velocity

Technical data

Vertical tube

- height: 2m
- diameter: 50mm

Tanks

- feed: 20L
- collector: 40L

Measuring ranges

- velocity: 0...36m/s
- differential pressure: 0...10kPa
- pressure: 0...1bar

230V, 50Hz, 1 phase
120V, 60Hz, 1 phase
UL/CSA optional
LxWxH: 1280x800x2880mm
Weight: approx. 190kg

Required for operation

compressed air: min. 1500mbar, 60m³/h

Scope of delivery

- 1 trainer
- 4 nozzles
- 1 packing unit of plastic granulate (PP; 30kg)
- 1 set of accessories
- 1 set of instructional material

Introduction

Overview The GUNT learning concepts of thermal process engineering	086
---	-----

Drying and evaporation

Basic knowledge Drying	088
-------------------------------	-----

Basic knowledge Evaporation	089
------------------------------------	-----

CE 130 Convection drying	090
---------------------------------	-----

CE 715 Rising film evaporation	092
---------------------------------------	-----

Developing the unit operations in thermal process engineering by experiment

We offer you a complete range of products for experimentally demonstrating and developing unit operations in thermal process engineering.

Our experimental units make it easier to understand the complex theoretical principles on which thermal separation processes are based. With these units the motive forces and the effects of heat and material transfer processes necessary for separation can be observed and tested. This prepares the trainee for responsible use of actual systems. In many cases, our products feature data acquisition software to support effective learning.

Distillation/rectification

Basic knowledge Distillation	094
-------------------------------------	-----

Basic knowledge Rectification	095
--------------------------------------	-----

Overview CE 600 Continuous rectification	096
---	-----

CE 600 Continuous rectification	098
--	-----

CE 602 Discontinuous rectification	100
---	-----

CE 610 Comparison of rectification columns	102
---	-----

Absorption and adsorption

Basic knowledge Absorption	104
-----------------------------------	-----

Basic knowledge Adsorption	105
-----------------------------------	-----

Overview CE 400 Gas absorption	106
---------------------------------------	-----

CE 400 Gas absorption	108
------------------------------	-----

CE 405 Falling film absorption	110
---------------------------------------	-----

CE 540 Adsorptive air drying	112
-------------------------------------	-----

Overview CE 583 Adsorption	114
-----------------------------------	-----

CE 583 Adsorption	116
--------------------------	-----

Crystallisation and membrane separation processes

Basic knowledge Crystallisation	118
--	-----

Basic knowledge Membrane separation processes	119
--	-----

CE 520 Cooling crystallisation	120
---------------------------------------	-----

CE 530 Reverse osmosis	122
-------------------------------	-----

Extraction

Basic knowledge Liquid-liquid extraction	124
---	-----

Basic knowledge Solid-liquid extraction	125
--	-----

CE 620 Liquid-liquid extraction	126
--	-----

CE 630 Solid-liquid extraction	128
---------------------------------------	-----

Mass transfer

Basic knowledge Mass transfer	130
--------------------------------------	-----

CE 110 Diffusion in liquids and gases	132
--	-----

The GUNT learning concepts of thermal process engineering

What does thermal process engineering involve?

The basis of thermal process engineering is thermal separation processes. In mixtures made up of at least two components, heat and material transfer processes are used to selectively change the composition (concentration) of the mixture. The motive forces for these transfer processes (temperature and concentration differences) are created by adding an opposite

phase selectively for one or more components in the mixture. Both the mixture of substances to be separated and the opposite phase can be in either solid, liquid or gaseous form. The processes are referred to as phase equilibrium processes and classified based on the combination of phases.

How can the unit operations in thermal process engineering be classified?

Phase equilibrium processes			
liquid / gaseous	evaporation	distillation / rectification	absorption
liquid / liquid	extraction	membrane separation / reverse osmosis	
solid / liquid		crystallisation	adsorption
solid / gaseous	drying		

Modelling of thermal separation processes is based on the absolute laws of conservation for mass, energy and momentum, as well as phase equilibrium and kinetic methods for modelling heat and material transfer flows. The parameters in the kinetic methods must be measured and the heat and material transfer flows optimised. Practical experiments are essential to obtain a comprehensive understanding of the fundamental recurring process engineering principles such as parallel and countercurrent flow, multistage processes, design of active surfaces and uniform progression of motive forces. Planning, setting up and performing experiments to determine modelling parameters is communicated most clearly and comprehensibly through the use of experimental units.



Prof. Dr.-Ing. habil. Kurt Gramlich (Anhalt University), our technical adviser on thermal process engineering

Prof. Gramlich advised us when we were setting up this range and contributed his many years of experience in the area of thermal process engineering.

The text on this page was written by Prof. Gramlich.

Our training systems for thermal process engineering

Drying	CE 130 Convection drying
Evaporation	CE 715 Rising film evaporation
Distillation and rectification	CE 600 Continuous rectification CE 602 Discontinuous rectification CE 610 Comparison of rectification columns
Absorption	CE 400 Gas absorption CE 405 Falling film absorption
Adsorption	CE 540 Adsorptive air drying CE 583 Adsorption
Extraction	CE 620 Liquid-liquid extraction CE 630 Solid-liquid extraction
Crystallisation	CE 520 Cooling crystallisation
Membrane separation processes	CE 530 Reverse osmosis
Mass transfer	CE 110 Diffusion in liquids and gases



CE 600
Continuous
rectification

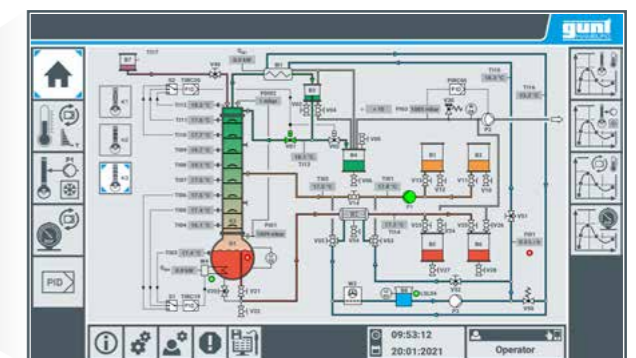

User interface of the touch screen

Basic knowledge Drying

In general, drying refers to the removal of moisture from solids, gases or liquids. For drying gases and liquids, adsorption is normally used. The food technology industry is an example of where drying solids on a large scale is important.

Thermal drying of solids involves removing moisture from the material by vaporisation or evaporation. The drying characteristics depend on how the moisture is retained within the material. In the first instance, the liquid adhering to the surface of the

material to be dried can be removed by vaporisation or evaporation. Once this liquid has been removed, drying of the moisture contained within the capillaries and pores of the material begins. The drying speed reduces due to the need to overcome capillary forces and diffusion resistance. Crystal water which is bonded into the crystal structure of the material, can only be removed by intense heating in addition to low drying speed.

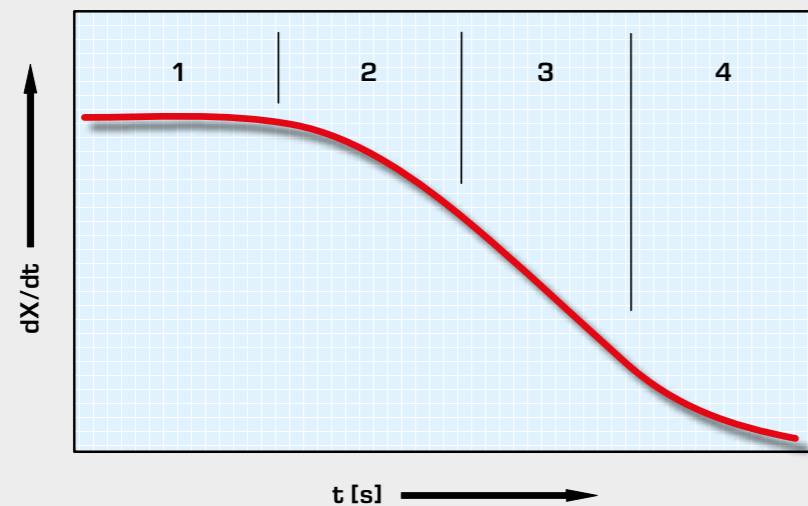

Drying characteristics of a solid with division into drying sections (1-4):

dX/dt drying rate, X moisture content [kg (water)/kg (dry solid)], t drying time;
1 surface moisture, 2 capillary moisture, 3 pore moisture, 4 moisture in crystal structure

A wide range of process engineering principles are used in drying, due to the variety of industrially moisture containing materials. These materials can have extremely different behaviours.

The following unit operations can be distinguished:

■ Convection drying

A flowing gas transfers the heat necessary for drying to the material by convection. As well as delivering heat, the gas is also used to remove the moisture given off by the material.

■ Contact drying

The material is placed on or is passed over heated surfaces. Heat is predominantly transferred to the material by conduction.

■ Radiation drying

The material absorbs emitted electromagnetic radiation from sources of radiation (e.g. infrared radiators). Heating and evaporation occur not only at the surface of the material but also within it.

■ Freeze drying

The frozen material is placed in a vacuum below its triple point. Moisture is removed from the material, by changing it directly from a solid to a gaseous state.

■ High frequency drying

The material is exposed to high frequency electrical fields between the electrodes of a plate capacitor. A part of field energy is absorbed by the material resulting in internal heating and removal of moisture.

Basic knowledge Evaporation

In the context of thermal process engineering, evaporation is understood to be the separation of a solvent from a solution. An example of a solution is salt water, in which salt (the dissolved solid) is present in the solvent, i.e. water. The addition of heat exclusively evaporates the pure solvent (water in this example)

from the solution and carries it away. The remaining solution thus has a higher concentration of dissolved solid than before the addition of heat.

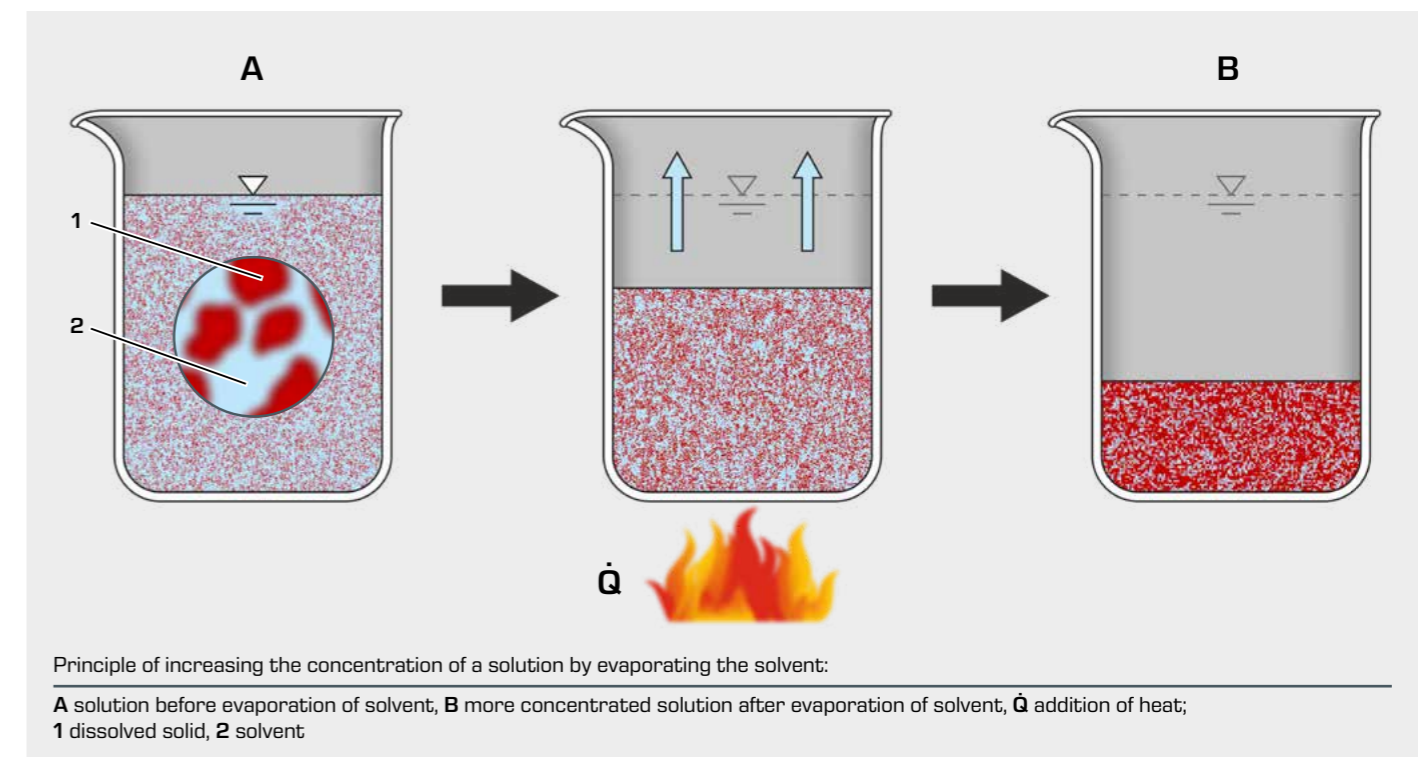

Principle of increasing the concentration of a solution by evaporating the solvent:

A solution before evaporation of solvent, B more concentrated solution after evaporation of solvent, \dot{Q} addition of heat;
1 dissolved solid, 2 solvent

The aim of evaporation can be to obtain the solvent, to create a concentrate solution or to precipitate the dissolved solid by crystallisation.

Industrial applications of evaporation include:

■ Increasing the concentration of solutions i.e., salts, alkalis, acids, plastic solutions, fruit and vegetable juices, milk etc.

■ Obtaining products i.e., sugar from juices, salt from brine, drinking water from sea water.

Different evaporator designs are used depending on the aim of the separation process. Essentially they are heat exchangers in which steam is normally used as the heating medium. The

solution can pass through the evaporator tubes once (straight-through evaporator) or several times (circulation evaporator). For solutions containing temperature-sensitive substances, thin film evaporators are used. These limit the retention time of the solution in areas with high temperatures.

CE 130

Convection drying



Description

- convection dryer for drying experiments on granular solids
- plotting of drying curves

Convection dryers are often used for drying solids in food technology. The CE 130 can be used to investigate and demonstrate the process of convection drying of granular solids.

Four corrosion resistant removable plates are available for drying the solid. They are placed in a drying channel. The plates containing the solid to be dried are exposed to an air flow in the channel. The air flow heats the solid and also removes any moisture released. Air velocity can be adjusted by the speed of a fan. An adjustable heater allows the heating of the air. The transparent door in the drying channel allows the drying process to be observed.

A digital balance can be used to follow the changes in weight of the solid due to evaporation or vaporisation of moisture during operation. The air temperature and the relative humidity of the air are measured and digitally displayed by a single combined temperature and humidity sensor before and after the air flow passes over the solid. A further sensor measures the air velocity.

The relevant measured parameters (changes in weight, humidity, temperature, air velocity) can be transferred directly to a PC, where they can then be further processed.

Learning objectives/experiments

- influence of air temperature and humidity on drying intensity
- plotting of drying curves with constant external conditions
- determination of drying rate with different air parameters and different solid properties
- evaluation of drying processes using energy and mass balances

CE 130

Convection drying

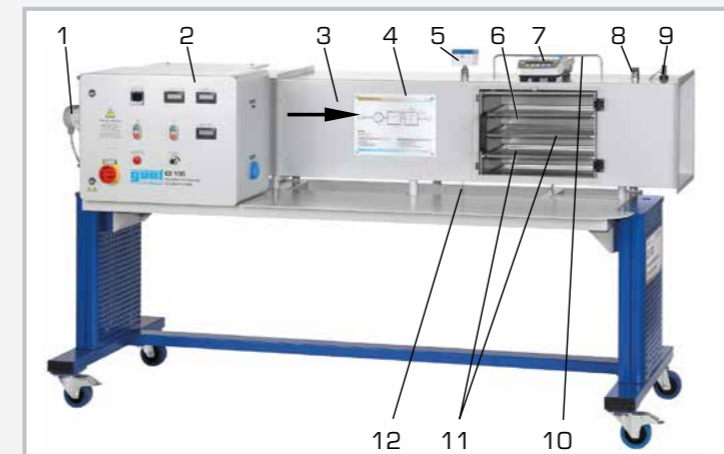

1 fan, 2 switch cabinet with digital displays, 3 drying channel, 4 process schematic, 5 measuring point with humidity and temperature sensor, 6 transparent door, 7 digital balance, 8 measuring point for humidity and temperature, 9 air velocity sensor, 10 bracket for drying plates, 11 drying plates, 12 temperature sensor of the controller

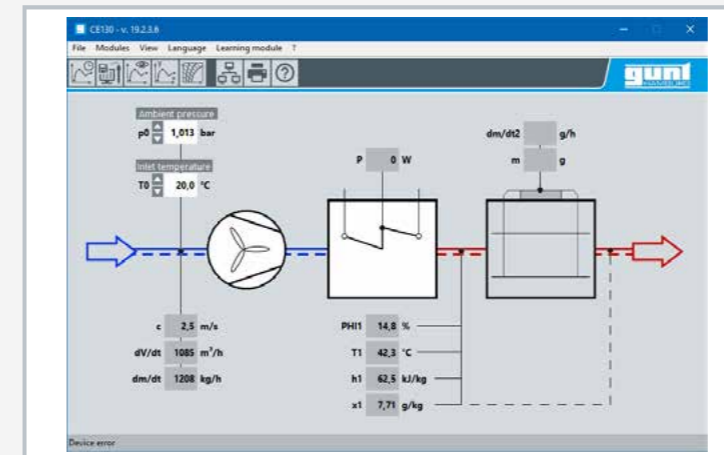

Software screenshot

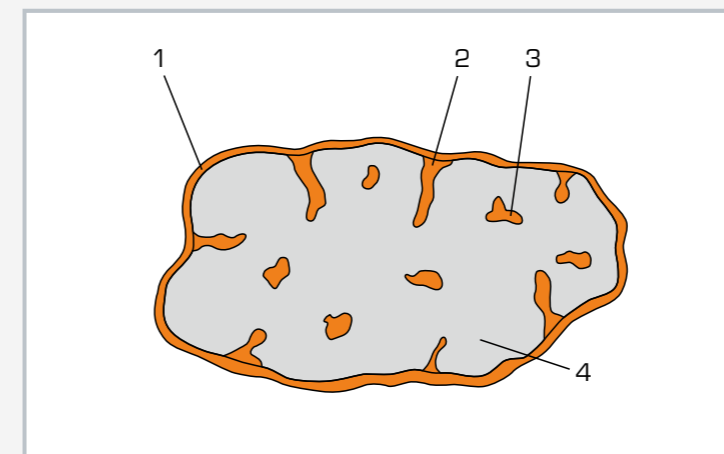

Humid drying material: 1 surface moisture, 2 capillary moisture, 3 pore moisture, 4 crystal water

Specification

- [1] drier for investigating convection drying of solids
- [2] drying on 4 corrosion resistant plates in a drying channel with an air flow
- [3] adjustment of air velocity via speed of fan
- [4] air heating with controlled heater
- [5] digital balance for measuring the change of weight during drying
- [6] 1 combined sensor for measurement of humidity and temperature before and after the solid sample
- [7] 1 air velocity sensor
- [8] GUNT software for data acquisition via USB under Windows 8.1, 10

Technical data

Drying channel

- length: 2340mm (with fan)
- internal dimensions: 350x350mm

Fan

- power: 33W
- max. output: 700m³/h
- max. speed: 950min⁻¹

Heater

- power: 0...6750W
- with adjustable temperature limiter

Balance

- measuring range: 0...10000g
- resolution: 0,1g

Measuring ranges

- air humidity: 0...100% r.F.
- temperature: 0...125°C
- flow velocity: 0...2,5m/s

400V, 50Hz, 3 phases
400V, 60Hz, 3 phases
230V, 60Hz, 3 phases
UL/CSA optional
LxWxH: 2350x800x1200mm
Weight: approx. 175kg

Required for operation

PC with Windows recommended

Scope of delivery

- 1 trainer
- 1 balance
- 4 drying plates
- 1 GUNT software + USB cable
- 1 set of instructional material

CE 715

Rising film evaporation



The illustration shows a similar unit

Description

- rising film evaporator for increasing the concentration of temperature-sensitive solutions
- hygienic operation due to carefully selected materials such as stainless steel and glass
- cleaning possible while installed
- counterflow process

Evaporators are used in process engineering and food technology for increasing the concentration of solutions. Part of the solvent is removed by evaporation, which means that the solution retains a higher concentration of dissolved solids. Film evaporators are used in particular for temperature-sensitive solutions such as milk.

The CE 715 allows the operating behaviour of a rising film evaporator to be investigated. The untreated solution is fed from the feed tank below into the evaporator. The evaporator is a double pipe heat exchanger that is heated by steam. The steam pressure on the casing side is adjusted with a PID controller. A cyclone is installed after the evaporator to separate the evaporated solvent and the concentrated solution. The solvent vapour removed is condensed in a water-cooled condenser and collected in a tank. The concentrated solution can also be collected in a tank or fed back into the evaporator for the concentration to be increased further.

The two tanks, the cyclone and the condenser are made of glass for better observation. The system can also be operated under a vacuum to reduce the boiling point of the solvent. All relevant pressures, temperatures and flow rates are measured to allow evaluation and monitoring of the process.

To clean the system while installed, a pump and cleaning nozzles are fitted in the condensate and concentrate tanks.

Common salt and water are the recommended materials for experiments.

Learning objectives/experiments

- fundamental principle of film evaporation for increasing the concentration of temperature-sensitive solutions
- investigation of the variables influencing the solid concentration in the solution
- influence of pressure and feed flow rate on the separating process
- influence of flow rate and pressure of the heating steam on the separating process
- investigation of the variables influencing the energy efficiency of the process
- energy balances at heat exchangers
- system cleaning while installed

CE 715

Rising film evaporation

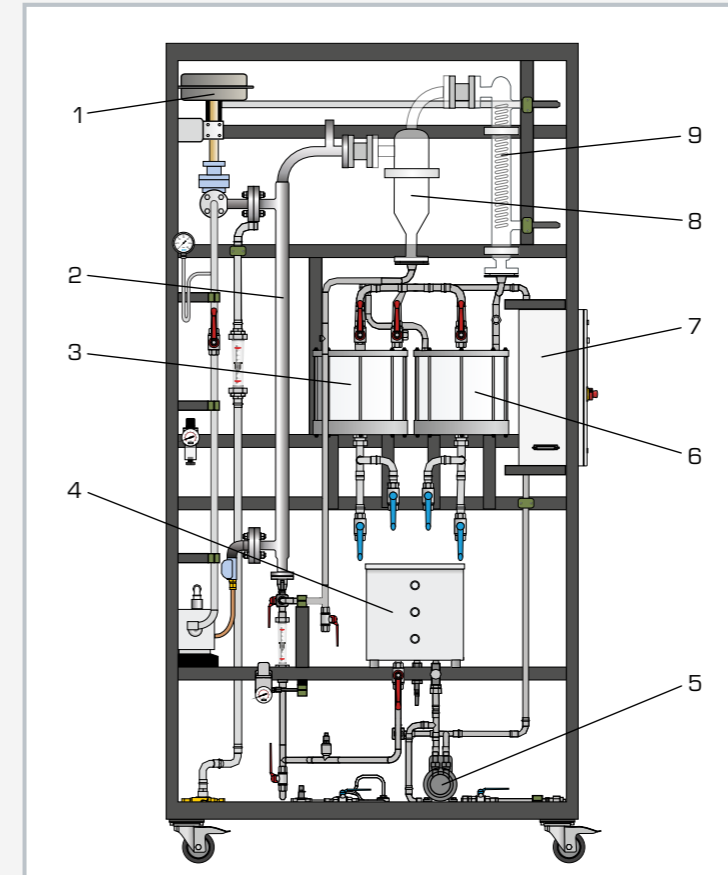

1 heating steam control valve, 2 rising film evaporator, 3 concentrate tank, 4 feed tank, 5 cleaning pump, 6 condensate tank, 7 switch cabinet, 8 cyclone, 9 condenser

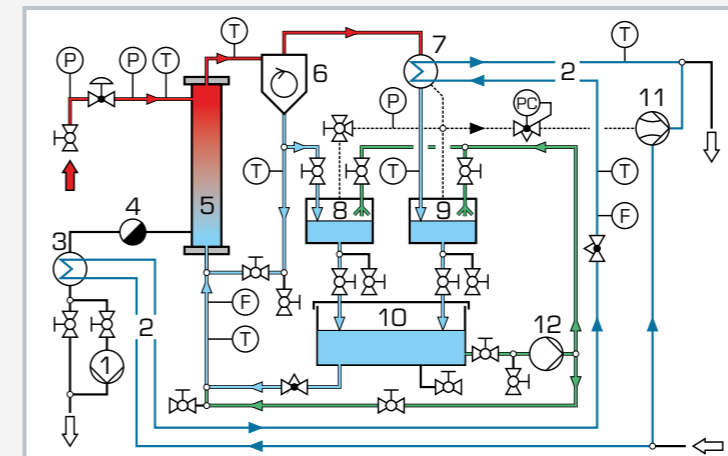

1 heating steam condensate pump, 2 cooling water, 3 condensate cooler, 4 steam trap, 5 rising film evaporator, 6 cyclone, 7 condenser, 8 concentrate tank, 9 condensate tank, 10 feed tank, 11 water jet pump, 12 cleaning pump; F flow rate, P pressure, L level, T temperature

Specification

- [1] rising film evaporator for increasing the concentration of temperature-sensitive solutions
- [2] stainless steel steam-heated single pipe evaporator
- [3] control valve for adjustment of steam pressure via PID controller
- [4] water jet pump and vacuum controller to reduce the evaporation temperature
- [5] separation of concentrated solution and evaporated solvent using glass cyclone
- [6] glass condenser for condensation of removed solvent vapour
- [7] stainless steel feed tank
- [8] glass tanks for concentrate and condensate
- [9] measurement of flow rate, pressure and temperature
- [10] steam supply from laboratory network or CE 715.01

Technical data

Rising film evaporator

- heat transfer surface: approx. 0,08m²
- length: approx. 1,2m

Control valve: K_{vs} value: 0,4m³/h
Water jet pump

- final vacuum: approx. 100mbar
- flow rate: approx. 90L/min

Vacuum controller: -100...0kPa

Condenser for solvent vapour

- heat transfer surface: approx. 0,2m²

Tanks

- feed: approx. 30L
- concentrate, condensate: approx. 10L each

Measuring ranges

- temperature: 7x 0...170°C
- pressure: -1...1bar; 0...6bar (abs); 0...10bar
- flow rate: 2...36L/h; 0...1000L/h

230V, 50Hz, 1 phase

230V, 60Hz, 1 phase

120V, 60Hz, 1 phase

UL/CSA optional

LxWxH: 1420x750x2640mm

Weight: approx. 300kg

Required for operation

cooling water / wastewater: min. 500L/h
compressed air [control valve]: 3...4bar, max. 300L/h
steam: min. 3bar, min. 5kg/h or CE 715.01

Scope of delivery

- 1 trainer
- 1 set of hoses
- 1 set of instructional material

Basic knowledge Distillation

Distillation is a unit operation that can be used to separate homogeneous liquid mixtures. It utilises the different volatility of the components of the mixture to be separated. Volatility refers to the tendency of a substance to pass from the liquid phase

into the gas phase. Examples of volatile liquids include acetone, alcohol and petrol.

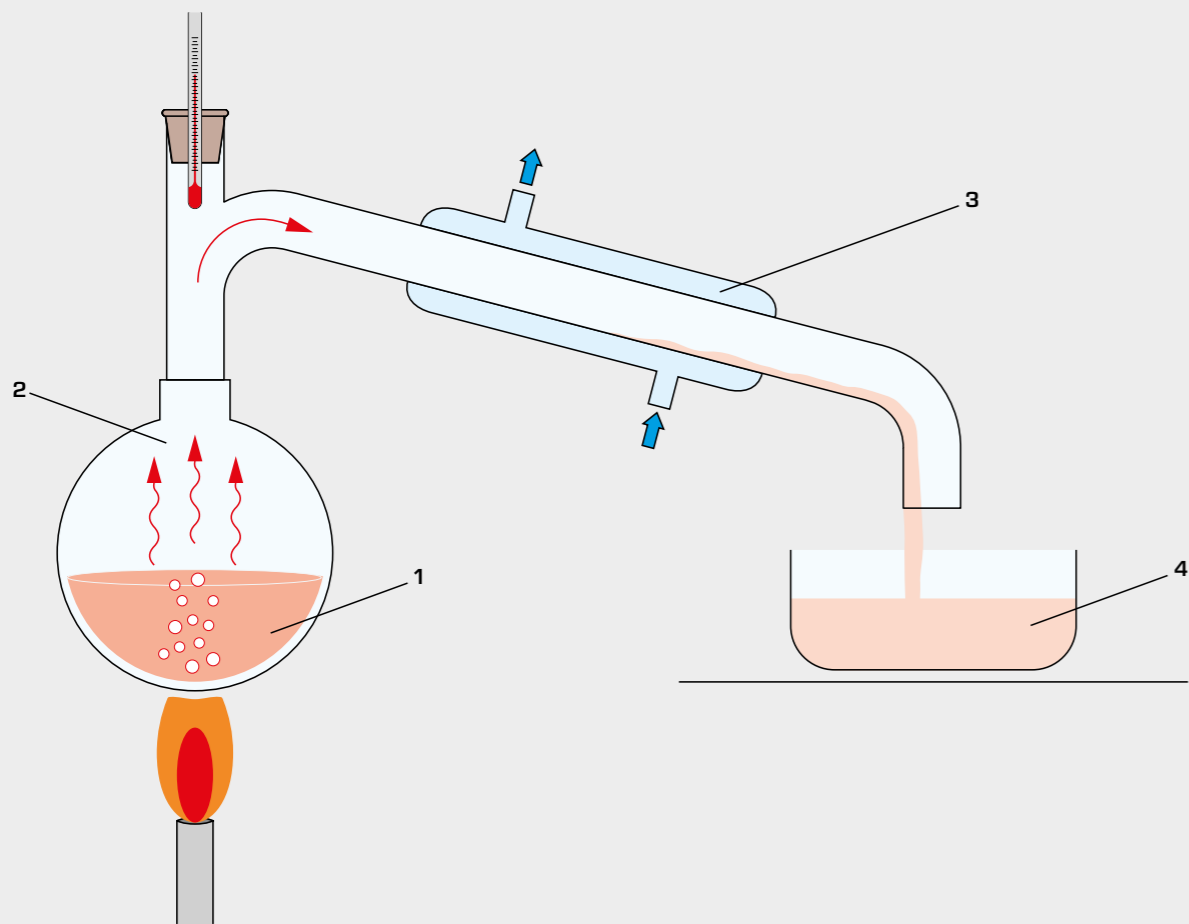

Principle of distillation:

1 boiling liquid mixture, 2 upward-moving vapour phase, 3 condenser, 4 distillate

To achieve separation, the liquid mixture is brought to boiling point. The resulting vapour phase is made up of several components, mainly the more volatile components of the mixture. The vapour phase is separated from the liquid phase and condensed (distillate). The less volatile components predominantly remain in the liquid phase.

Distillation does not result in complete separation of the liquid mixture, but rather its division into two mixtures with different contents of volatile and less volatile components.

The separating principle is based on the fact that the content of volatile components is greater in the vapour phase than in the liquid phase.

Basic knowledge Rectification

Rectification is an application of distillation. It is used for substances that are required in high purity and/or large quantities, for example to fractionate crude oil.

If the distillate obtained during distillation is distilled again, a new distillate is obtained with an even higher concentration of volatile components. As the procedure is repeated, the concentration of volatile components in the distillate increases on each occasion.

In practice, this multi-stage distillation process is carried out in the form of countercurrent distillation (rectification) in a column.

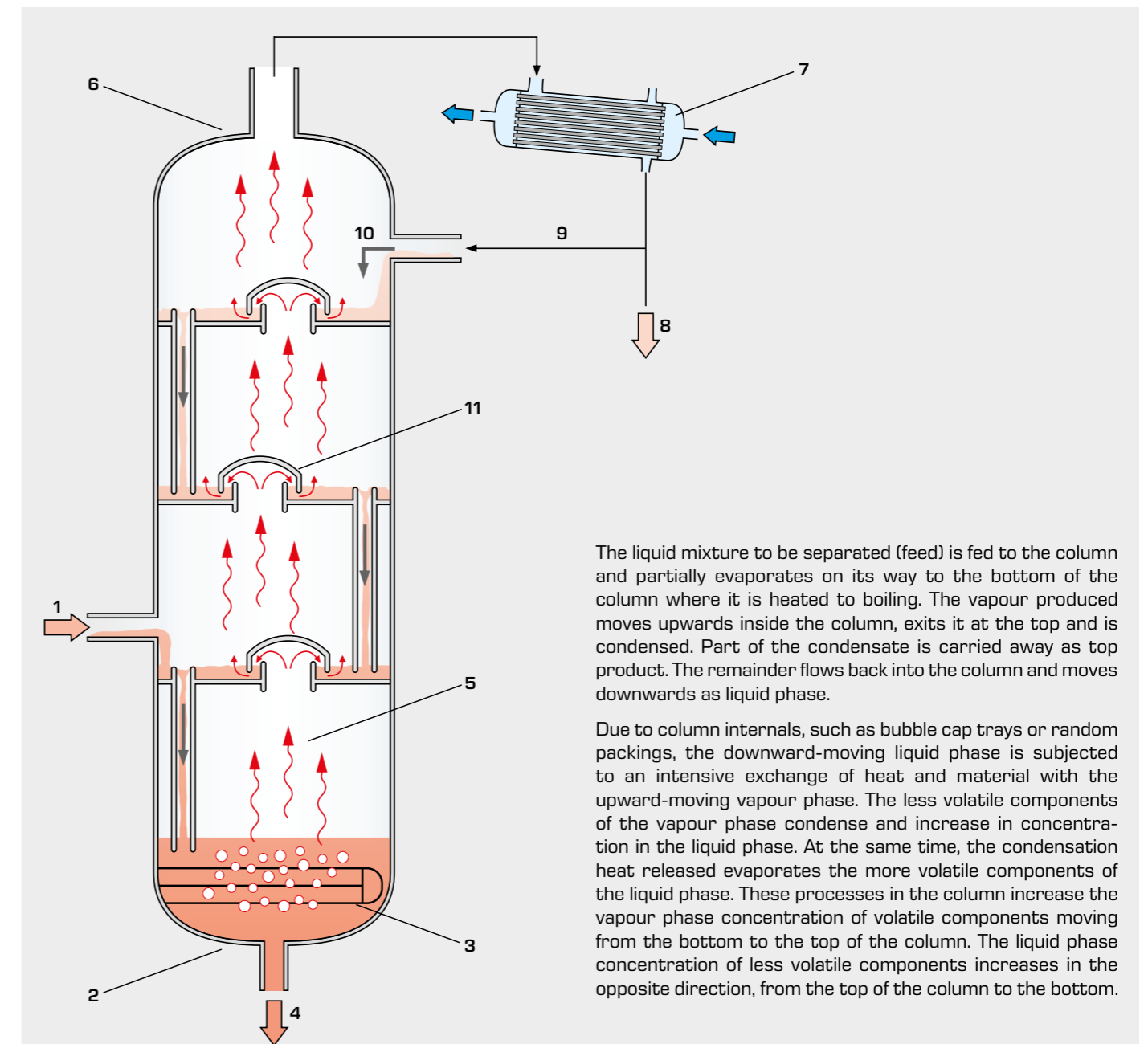

Simplified illustration of a rectification column:

1 feed, 2 bottom of column, 3 bottom heating, 4 bottom product, 5 upward-moving vapour phase, 6 top of column, 7 condenser, 8 top product, 9 reflux, 10 downward-moving liquid phase, 11 tray (here: bubble cap tray)

The liquid mixture to be separated (feed) is fed to the column and partially evaporates on its way to the bottom of the column where it is heated to boiling. The vapour produced moves upwards inside the column, exits it at the top and is condensed. Part of the condensate is carried away as top product. The remainder flows back into the column and moves downwards as liquid phase.

Due to column internals, such as bubble cap trays or random packings, the downward-moving liquid phase is subjected to an intensive exchange of heat and material with the upward-moving vapour phase. The less volatile components of the vapour phase condense and increase in concentration in the liquid phase. At the same time, the condensation heat released evaporates the more volatile components of the vapour phase. These processes in the column increase the vapour phase concentration of volatile components moving from the bottom to the top of the column. The liquid phase concentration of less volatile components increases in the opposite direction, from the top of the column to the bottom.

Overview

CE 600 Continuous rectification

Liquid mixtures consisting of individual liquids that are soluble in each other can be separated by thermal processes such as distillation. Rectification is an energy-optimised distillation carried out several times in succession.

CE 600 represents continuous rectification on a laboratory scale. Three different types of columns are available for the experiments:

- bubble cap tray column
- sieve tray column
- packed column

The bubble cap tray column and sieve tray column each have eight trays. The liquid mixture to be separated can be fed into the columns at three different heights. The feed can be preheated by means of a heat exchanger.



- 1 column
- 2 bottom with heater
- 3 heat exchanger
- 4 bottom product tank
- 5 diaphragm pump
- 6 water tank for cooling water circuit
- 7 feed tank
- 8 top product tank
- 9 phase separation tank
- 10 top product condenser

Learning objectives

- investigation and comparison of sieve tray, bubble cap tray and packed columns
 - ▶ in continuous mode
 - ▶ in discontinuous mode
 - ▶ in vacuum mode
 - ▶ with different inlet heights for the feed flow
 - ▶ with different numbers of trays (sieve tray and bubble cap tray column)
- practice-oriented temperature control in the column
 - ▶ reflux ratio as actuator for the top of the column
 - ▶ heating power as actuator for the column bottom
- determination of temperature profiles
- pressure loss over the column
- energy efficiency increase due to feed preheating

About the product:

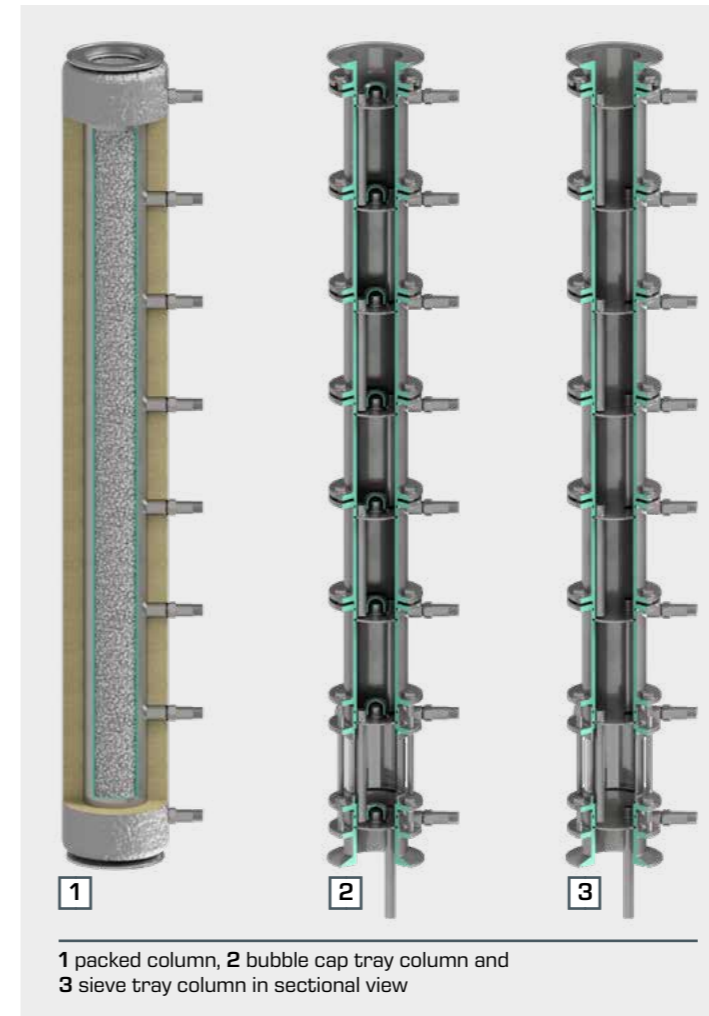

1 packed column, 2 bubble cap tray column and 3 sieve tray column in sectional view

Packed column

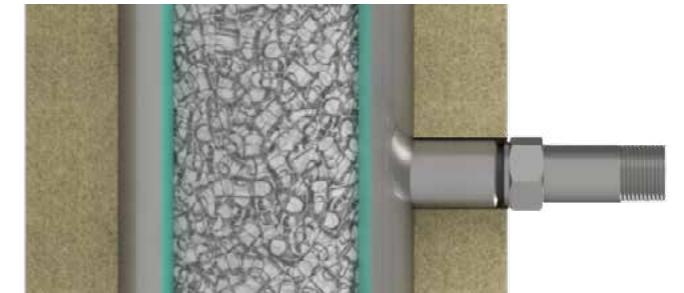

A packed column consists of a bed of packing. The packing has a very large surface area, which is used for separation. The liquid phase flows downwards through the packed bed and the gas phase flows upwards. During this process, a mass transfer takes place between the phases.

Bubble cap tray column

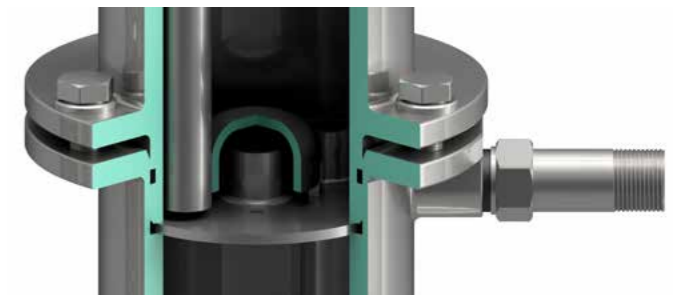

Each bubble cap consists of a chimney (riser) into which the gas phase flows from below. The bubble cap located above the chimney diverts the gas phase and allows it to escape near the tray. During operation, the bubble cap is in the liquid phase, meaning that the gas phase rises through the liquid phase as it exits. During this process, a mass transfer takes place between the phases.

Sieve tray column

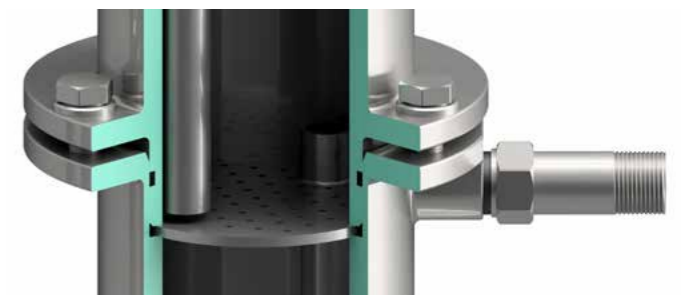

Each sieve tray consists of three sections: the feed through a pipe from the tray above, the sieve in the middle of the tray and the outlet to the tray below. During operation, the gas phase flows through the sieve from below and rises through the liquid phase. During this process, a mass transfer takes place between the phases.

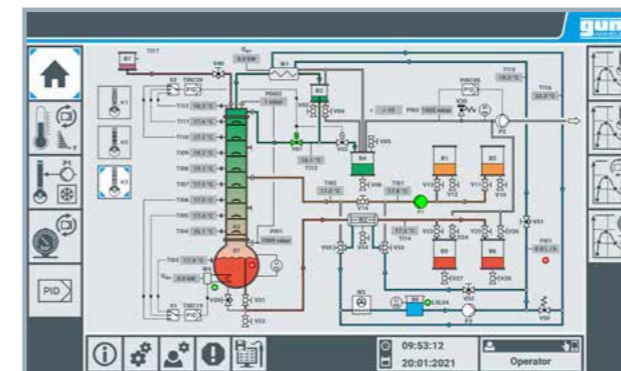

User interface of the touch screen

PLC and software

The system is controlled by an integrated PLC with touch screen. The measured values are displayed on the touch screen and can simultaneously be viewed directly on a PC or mobile end device via LAN. The measured values can be analysed using the GUNT software.

CE 600

Continuous rectification

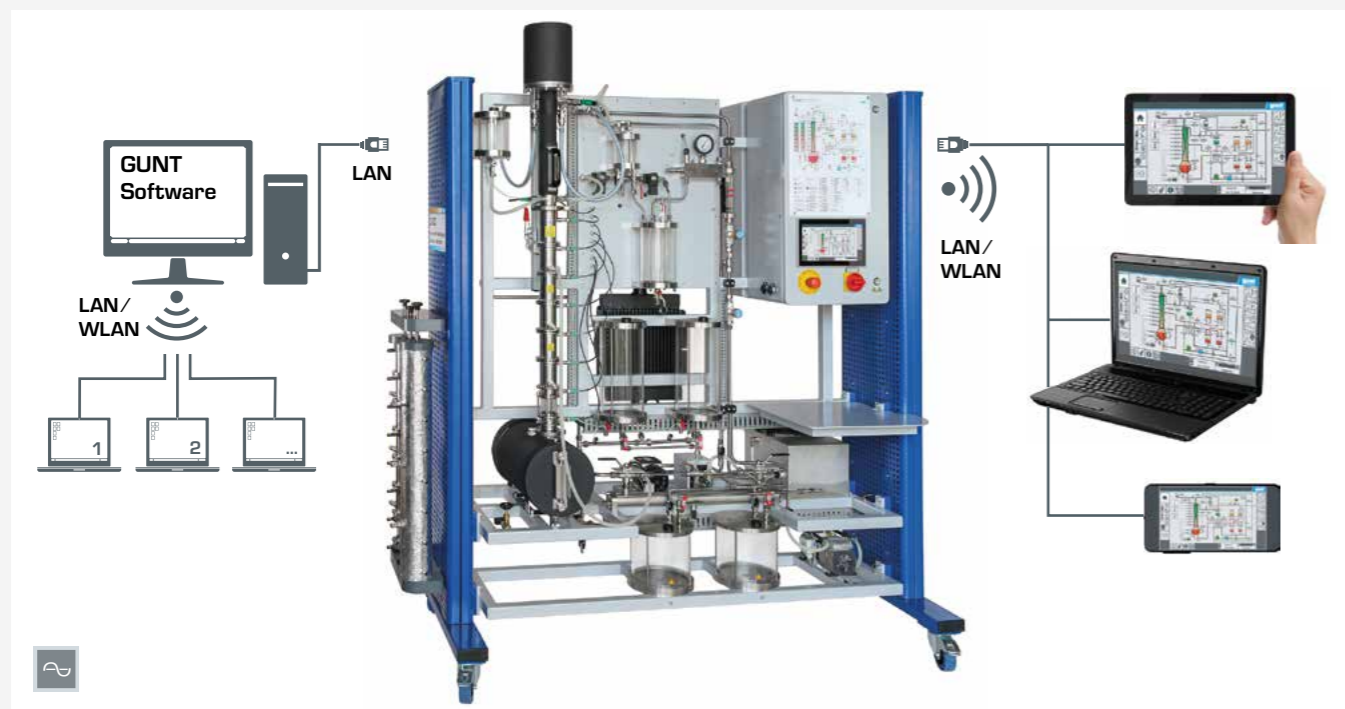

The illustration shows the CE 600 with built-in sieve tray column, screen mirroring is possible on different end devices

Description

- comparison of packed, sieve tray and bubble cap tray column
- vacuum mode possible by diaphragm pump
- plant control using an integrated PLC
- integrated router for operation and control via an end device and for screen mirroring on additional end devices: PC, tablet, smartphone

Rectification is an important thermal separation method in industry for separating homogeneous liquid mixtures, such as the fractionation of crude oil. Rectification represents an energy-efficient distillation process carried out in several consecutive stages.

CE 600 includes 3 interchangeable columns: a sieve tray column, a bubble cap tray column and a packed column. The separating liquid mixture can be fed to the columns at three different heights. The preheating of the feed is possible with the help of a heat exchanger. Ethanol/water is recommended as the liquid mixture for the CE 600.

The fed liquid mixture partially evaporates on its way to the bottom of the column where it is electrically heated

to boiling. The mixed vapour produced then moves upwards in the column. The mixed vapour contains a higher concentration of the component with the lower boiling point (ethanol). It leaves the top of the column and is condensed using a condenser. Part of this condensate is collected in a tank while the rest is fed back into the column as reflux. On its way downwards, it undergoes an intensive heat and material exchange with the rising mixed vapour. This exchange causes the vapour phase to become richer in ethanol and the liquid phase to become richer in water. The liquid phase moves to the bottom and can be collected in two tanks.

The trainer is controlled by the PLC via touch screen. By means of an integrated router, the trainer can alternatively be operated and controlled via an end device. The user interface can also be displayed on additional end devices (screen mirroring). Via the PLC, the measured values can be stored internally. Access to stored measured values is possible from end devices via WLAN with integrated router/LAN connection to the customer's own network. Via direct LAN connection the measured values can also be transmitted to a PC where they can be analysed using the GUNT software.

Learning objectives/experiments

- investigation and comparison of sieve tray, bubble cap tray and packed columns
 - ▶ in continuous mode
 - ▶ in discontinuous mode
 - ▶ in vacuum mode
 - ▶ with different inlet heights for the feed flow
 - ▶ with different numbers of trays (sieve tray and bubble cap tray column)
- practice-oriented temperature control in the column
 - ▶ reflux ratio as actuator for the top of the column
 - ▶ heating power as actuator for the column bottom
- determination of temperature profiles
- pressure loss over the column
- energy efficiency increase due to feed preheating
- screen mirroring: mirroring of the user interface on end devices
 - ▶ menu navigation independent of the user interface shown on the touch screen
 - ▶ different user levels available on the end device: for observing the experiments or for operation and control

CE 600

Continuous rectification

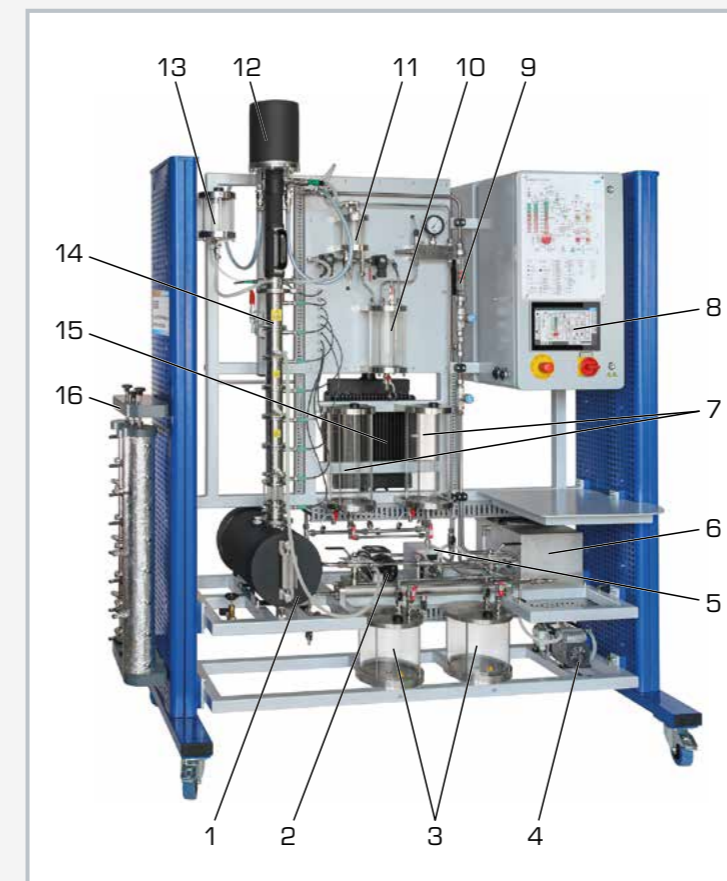

1 evaporator with column on top, 2 heat exchanger feed preheating/bottom product cooling, 3 bottom product tank, 4 diaphragm pump, 5 feed pump, 6 storage tank for cooling water circuit, 7 feed tank, 8 top product tank, 9 phase separation tank, 10 top product condenser, 11 solvent tank, 12 holding device columns

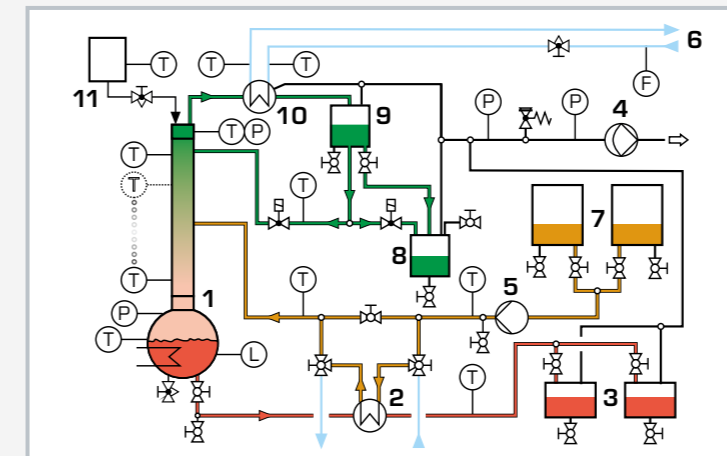

1 evaporator with column on top, 2 heat exchanger feed preheating/bottom product cooling, 3 bottom product tank, 4 diaphragm pump, 5 feed pump, 6 cooling water circuit, 7 feed tank, 8 top product tank, 9 phase separation tank, 10 top product condenser, 11 solvent tank;

F flow, L level, P pressure, T temperature;
orange: feed, red: bottom product, green: top product, blue: cooling water

Specification

- [1] continuous and discontinuous rectification
- [2] plant control with PLC via touch screen
- [3] integrated router for operation and control via an end device and for screen mirroring: mirroring of the user interface on up to 5 end devices
- [4] packed, sieve tray and bubble cap tray column, interchangeable
- [5] sieve tray and bubble cap tray column with 8 trays
- [6] packed column with Raschig rings
- [7] 3 feed inlets and 8 temperature sensors per column
- [8] electrically heated evaporator
- [9] condenser and phase separation tank for top product
- [10] adjustment of reflux ratio using valves
- [11] heat exchanger for feed preheating by bottom product or bottom product cooling by cooling water
- [12] water-saving due to closed cooling water circuit with water/air cooler
- [13] vacuum mode possible with diaphragm pump
- [14] areometer for determining the composition of feed/products included
- [15] data acquisition via PLC on internal memory, access to stored measured values via WLAN with integrated router/LAN connection to customer's own network
- [16] GUNT software for data acquisition via LAN under Windows 8.1, 10

Technical data

PLC: Eaton XV303 with I/O system XN300
Columns: height x inner diameter: 780x50mm
Feed pump: max. flow rate: 320mL/min
Cooling water pump: max. flow rate: 10L/min
Diaphragm pump: final vacuum approx. 213mbar abs.
Tanks

- feed: 2x approx. 5L
- bottom product: 2x approx. 5L
- top product: approx. 1,9L

 Heat transfer surfaces

- feed preheating/bottom cooling: approx. 0,03m²
- top product condenser: approx. 0,04m²

Measuring ranges

- temperature: 33x 0...150°C
- pressure sensor: 2x 0...2,5bar (column), 1x -1...1bar
- manometer: -1...0,6bar
- reflux ratio: 0...100%
- power: 0...4kW (heater)
- flow rate: 30...320L/h (cooling water)
- density: 0,7...1g/mL

400V, 50Hz, 3 phases; 400V, 60Hz, 3 phases
230V, 60Hz, 3 phases; UL/CSA optional
LxWxH: 1905x790x2200mm
Weight: approx. 400kg

Scope of delivery

- 1 trainer, 1 set of accessories
- 1 GUNT software, 1 set of instructional material

CE 602

Discontinuous rectification



Learning objectives/experiments

- investigation and comparison of sieve tray and packed columns
 - ▶ in discontinuous mode
 - ▶ in vacuum mode
 - ▶ with different reflux ratios
 - ▶ with different numbers of trays
- determination of concentration profiles
- determination of temperature profiles
- pressure loss over the column

Description

- **discontinuous rectification**
- **comparison of packed and sieve tray column**
- **vacuum mode possible**
- **trays in sieve tray column removable**

Distillation is used to separate liquid mixtures made up of individual liquids that are soluble in one another. Rectification refers to distillation in a counterflow. Ethanol/water is recommended as the liquid mixture for the CE 602. The liquid mixture is added to the evaporator (bottom) tank. The mixed vapour produced moves upwards in the column. The mixed vapour contains a higher concentration of the component with the lower boiling point (ethanol). It leaves the top of the column and is condensed using a condenser and a phase separation tank.

Part of the condensate is collected in a tank as product while the rest is fed back into the column. Here, on its way downwards, it undergoes further heating and material exchange with the rising mixed vapour. This exchange causes the vapour phase to become richer in ethanol and the liquid phase to become richer in water. The liquid phase moves to the bottom where it is collected.

A sieve tray column and a packed column are available. The packed column is filled with Raschig rings. The reflux ratio is adjusted using valves.

Relevant measured values are recorded by sensors and displayed digitally on the switch cabinet. The evaporator is adjusted using a PID controller.

A large, clear process schematic on the switch cabinet makes it easy to assign all the process variables.

CE 602

Discontinuous rectification

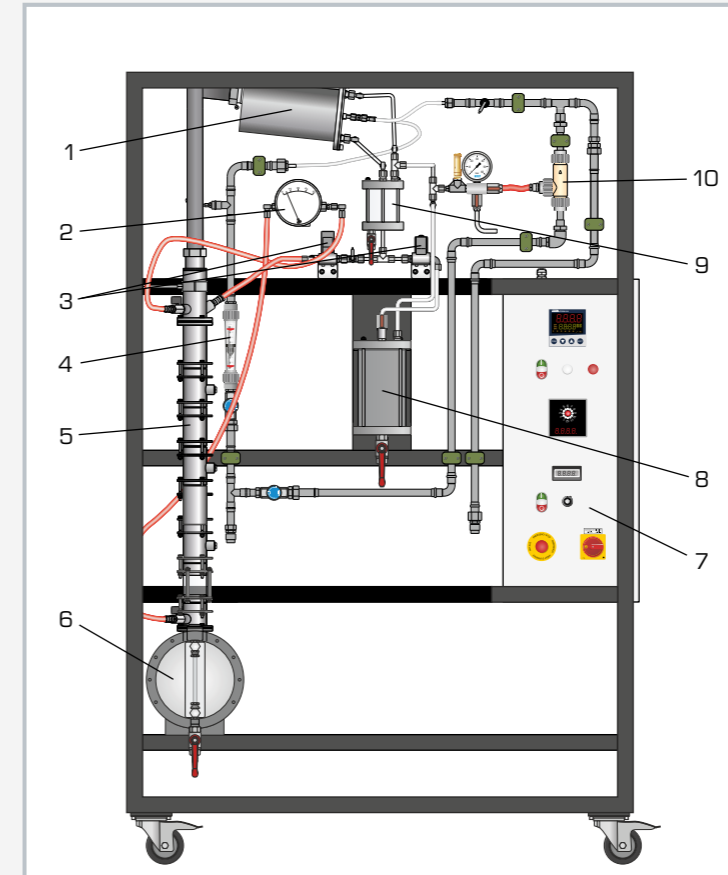

1 top product condenser, 2 manometer (column differential pressure), 3 valves (reflux ratio), 4 cooling water flow meter, 5 sieve tray or packed column, 6 evaporator, 7 switch cabinet with displays and controls, 8 top product tank, 9 phase separation tank, 10 water jet pump

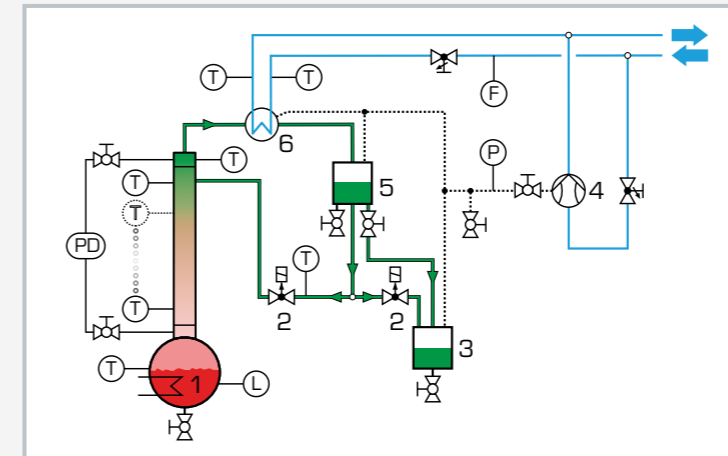

1 evaporator with column, 2 valves (reflux ratio), 3 top product tank, 4 water jet pump, 5 phase separation tank, 6 condenser; F flow rate, L level, P pressure, PD differential pressure, T temperature; blue line: cooling water

Specification

- [1] discontinuous rectification with packed and sieve tray column
- [2] interchangeable columns
- [3] sieve tray column with 8 trays
- [4] packed column with Raschig rings
- [5] vacuum mode possible with water jet pump
- [6] electrically heated evaporator
- [7] tank for top product
- [8] condenser and phase separation tank for top product
- [9] all tanks made of DURAN glass and stainless steel
- [10] adjustment of reflux ratio using valves
- [11] 8 temperature measuring points per column

Technical data

Columns: internal diameter: 50mm, height: 765mm
 Water jet pump: final vacuum: approx. 200mbar
 Tanks
 ■ top product: approx. 2000mL
 ■ phase separation: approx. 500mL

Evaporator
 ■ power output: 0...4kW
 ■ tank: approx. 10L

Heat transfer surface
 ■ top product condenser: approx. 0,04m²

Measuring ranges

- temperature: 13x 0...150°C
- reflux ratio: 0...100%
- flow rate: 30...320L/h (cooling water)
- differential pressure: 0...60mbar (column)
- manometer: -1...0,6bar

400V, 50Hz, 3 phases
 230V, 60Hz, 3 phases, 400V, 60Hz, 3 phases
 UL/CSA optional
 LxWxH: 1300x750x2100mm
 Weight: approx. 210kg

Required for operation

water connection: 500...1000L/h, drain

Scope of delivery

- 1 trainer
- 1 column
- 1 set of hoses
- 1 set of accessories
- 1 set of instructional material

CE 610

Comparison of rectification columns



Learning objectives/experiments

- investigation and comparison of a sieve tray column and a packed column
 - ▶ in continuous operation
 - ▶ with different pressures
 - ▶ with different reflux ratios
 - ▶ with different feed levels
- determination of the proportion of ethanol in the feed and in the products
- determination of the tray efficiency of the sieve trays
- evaluation using the McCabe-Thiele Diagram
- evaluation using the HTU-NTU concept

Description

- continuous rectification
- packed column and sieve tray column
- supply of process heat in the form of steam
- plant control with PLC via touch panel
- more than 40 measured quantities and 12 control loops

The rectification columns are used for the separation of liquid phases. They operate according to the principle of distillation. Distillation is a separation process that includes the partial evaporation of a liquid phase and the condensation of the resulting gas phase. The separation process of rectification is an energy-efficient distillation process with several stages. The substance mix recommended for the operation of the experimental plant is water-ethanol.

The CE 610 experimental plant is designed for the continuous operation of one rectification column at a time. The rectification columns are a packed column with pall rings and a sieve tray column with ten trays.

You can adjust various process parameter for the investigation of the rectification columns. These include, for example, the reflux ratio and the temperature measuring point for the temperature control. The effects of the changes are determined by means of the proportion of ethanol in the products (gravimetric measurement) thus also determining the separating capacity. For the evaluation of the experiments the software can be used to determine the theoretical separation steps by means of a McCabe-Thiele Diagram and the HTU-NTU concept.

The experimental plant is equipped with a comprehensive range of functions for measurement, control and operation that are controlled by a PLC. A touch panel displays the measured values and operating states and can be used to control the plant. At the same time, the measured values can be transmitted directly to a PC via USB where they can be analysed with the software.

The steam supply is realised via the laboratory supply or the optionally available electric steam generator (CE 715.01).

CE 610

Comparison of rectification columns

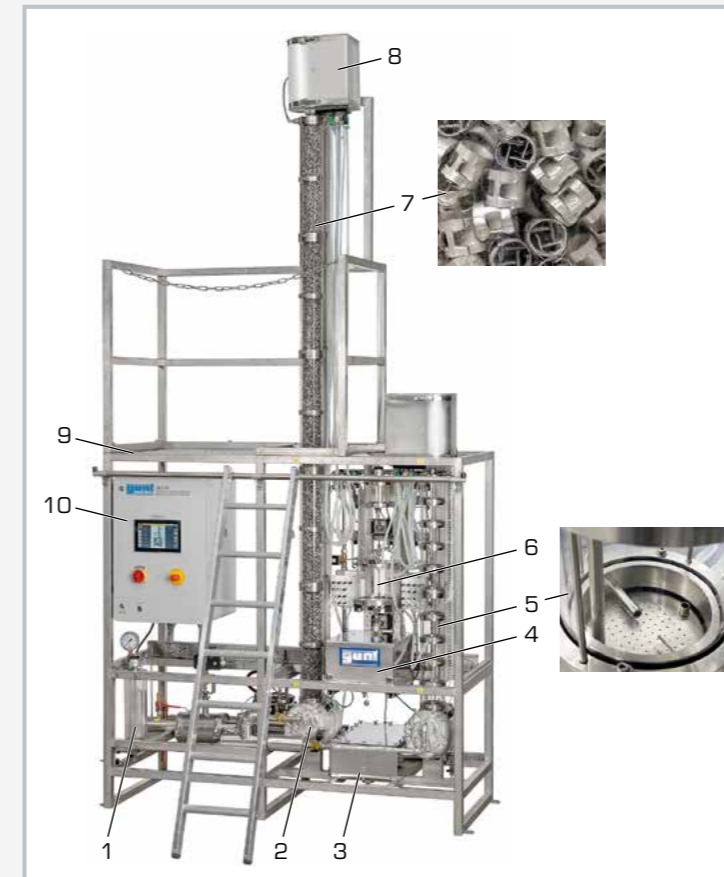

1 condensate tank, 2 bottom of column with evaporator, 3 bottom product tank, 4 feed tank, 5 sieve tray column with top condenser and column sump, 6 top product tank, 7 packed column, 8 top condenser, 9 platform, 10 switching cabinet with PLC and touch panel

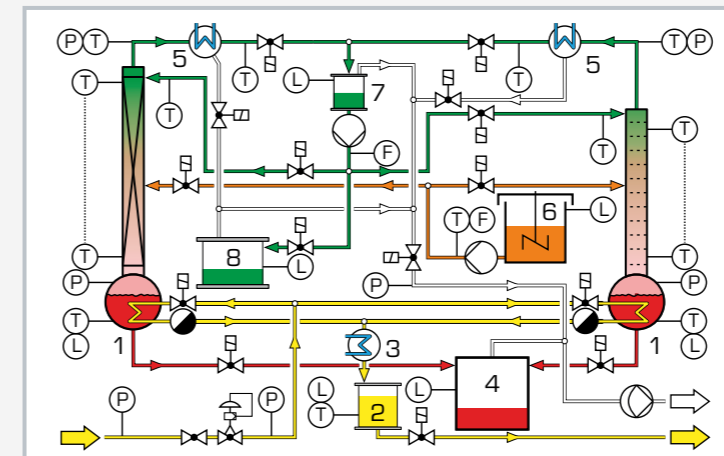

1 evaporator with column, 2 condensate tank, 3 condensate cooler, 4 bottom product tank, 5 top condenser, 6 feed tank, 7 phase separation tank, 8 top product tank; F flow rate, L level, P pressure, T temperature; red: bottom product, green: top product, orange: feed, blue: cooling water, yellow: steam, white: vacuum

Specification

- [1] continuous rectification with packed column or sieve tray column
- [2] variable reflux ratio
- [3] packed column with pall rings with 10 feed levels and temperature measurement
- [4] sieve tray column with 10 trays; each tray with feed and temperature measurement
- [5] tanks for feed, bottom and top product made of DURAN glass and stainless steel
- [6] operation at up to 115°C and 1,5bar
- [7] recording of all relevant variables with more than 40 sensors
- [8] PLC with touch panel for control of the plant
- [9] GUNT software for data acquisition via USB under Windows 8.1, 10

Technical data

Packed column

- inner diameter: 100mm
- packing height: 3000mm

Sieve tray column

- inner diameter: 100mm
- number of sieve trays: 10

Feed pump

- max. flow rate: 19L/h

Tank

- feed: 20L

Measuring ranges

- temperature: 31x 0...150°C
- flow rate: 1x 1,5...20L/h (feed)
- flow rate: 1x 0,3...105L/h (distillate)
- flow rate: 1x 24...720L/h (cooling water)
- pressure:
 - ▶ 5x 0...2,5bar (abs.)
 - ▶ 1x 0...5bar
 - ▶ 1x 0...10bar

230V, 50Hz, 1 phase
230V, 60Hz, 1 phase, 120V, 60Hz, 1 phase
UL/CSA optional
LxWxH: 2030x850x4000mm
Weight: approx. 480kg

Required for operation

cooling water (min. 800L/h, min. 4bar, max. 25°C),
steam (8kg/h, 4...6bar)
PC with Windows recommended

Scope of delivery

- 1 experimental plant
- 1 GUNT software + USB cable
- 1 set of accessories
- 1 set of instructional material

Basic knowledge

Absorption

Absorption is used to remove one or more gaseous components from a gas flow using a solvent. Absorption can have different aims:

- The gaseous component to be removed is a product that is wanted.

- The gaseous component to be removed is unwanted. This could be the case when removing contaminants from an exhaust gas flow.
- Production of a liquid; one example would be obtaining hydrochloric acid by absorption of HCl gas in water.

At least three substances are involved in the absorption: the gaseous component to be removed (absorbate), the carrier gas and the solvent (absorbent).

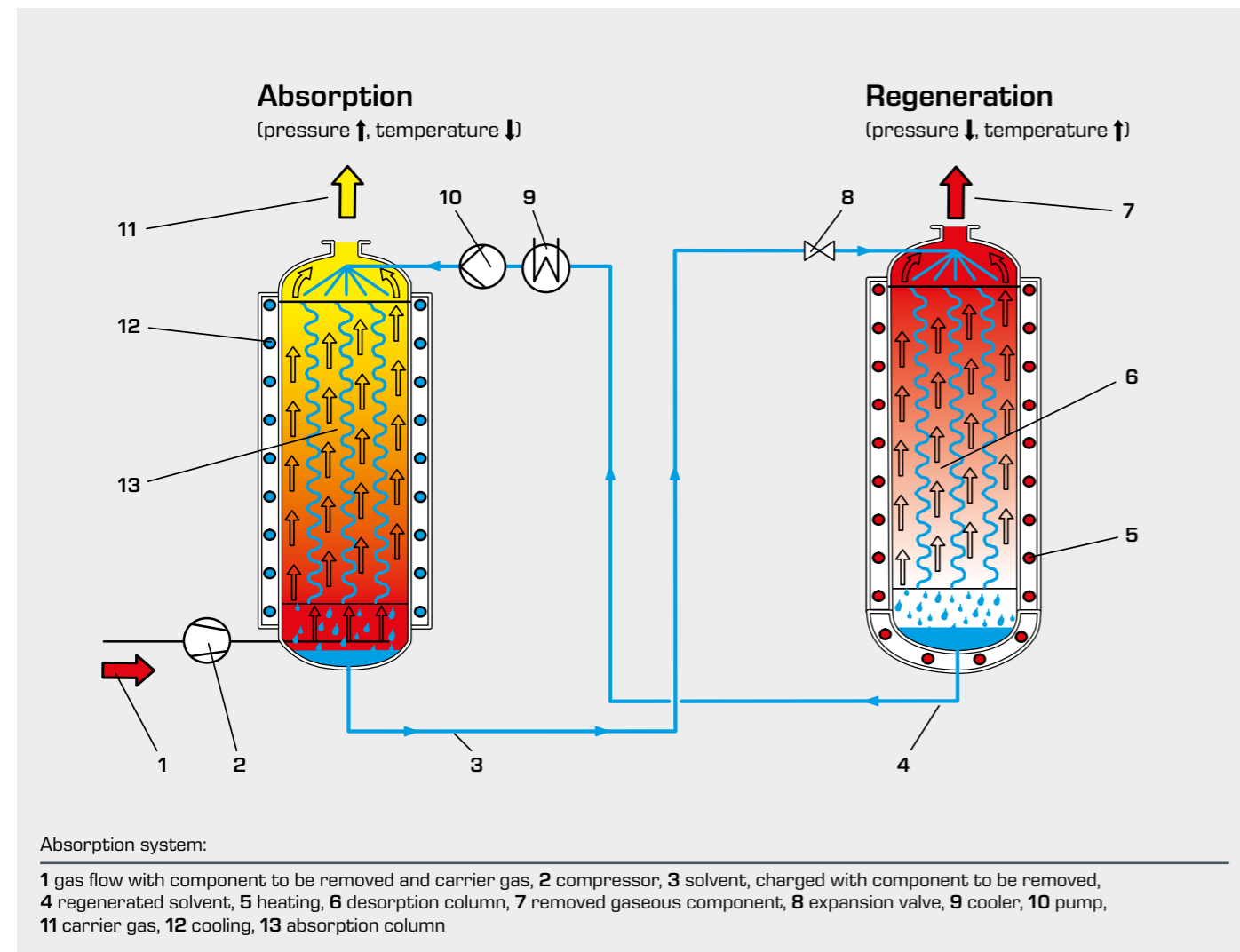

An appropriate solvent is used, depending on the gaseous component to be removed. The solvent selectively dissolves the gaseous component i.e. the solvent primarily absorbs the component(s) to be removed and not the carrier gas. High pressures and low temperatures enhance absorption. Depending

on the type of solvent, the gas is either absorbed by physical dissolving (physical absorption) or chemical bonding (chemical absorption).

To remove the gaseous components from the solvent, an absorption stage is normally followed by a desorption stage for

regeneration of the solvent. Here, high temperatures or low pressures are used to reduce the solubility of the gases in the solvent, thus expelling them. The solvent can therefore be recycled for further use.

Basic knowledge

Adsorption

Adsorption is used to remove individual components from a gas or liquid mixture. The component to be removed is physically or chemically bonded to a solid surface.

The solid is referred to as the adsorbent and the adsorbed component as the adsorbate. If adsorbent is brought into contact with adsorbate for long enough, an adsorption equilibrium is established. The adsorbent is then fully charged, and can absorb

no more adsorbate. The adsorbent in most widespread use is activated carbon. Activated carbon has a very distinct pore system. One gram of activated carbon has a pore surface area of approximately 1000 m².

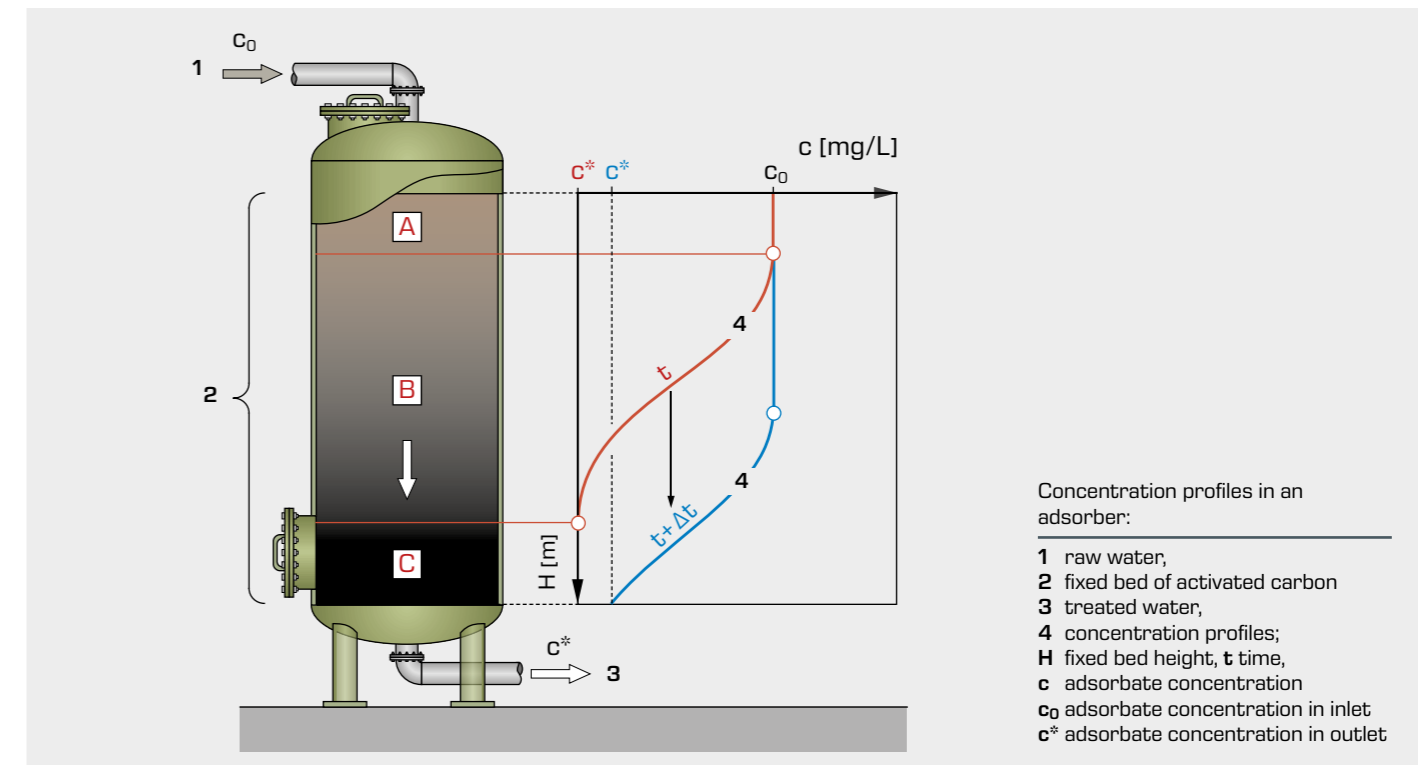

Adsorption is mainly implemented with continuous-flow adsorbent. In this case, the concentration profile marked in red on the illustration is established after the time t. It corresponds to the trend of the adsorbate concentration in the water along the fixed bed.

This concentration profile is divided into three zones:

- Zone A

The adsorbent is fully charged and can absorb no more adsorbate. So the adsorption equilibrium has been reached. The adsorbate concentration corresponds to the inlet concentration (c₀).

- Zone B

The adsorption equilibrium has not yet been reached, so adsorbate is still being adsorbed. This zone is known as the **mass transfer zone**.

- Zone C

Since the adsorbate has been fully removed in zone B, the adsorbent is still non-charged here, so the adsorbate concentration is zero.

Over time, the concentration profile moves through the fixed bed in the direction of the flow. At the time t + Δt it corresponds to the blue curve. There is no longer any non-charged adsorbent remaining in the fixed bed. The adsorbate concentration in the outlet (c*) is greater than zero. This state is termed the breakthrough, and the trend over time of the adsorbate concentration in the outlet is termed the breakthrough curve. The shape of the concentration profile indicates how well the capacity of an adsorbent is utilised before the breakthrough is reached. The narrower the mass transfer zone, the more effectively the capacity is utilised.

Overview

CE 400 Gas absorption

Absorption processes are used in air pollution control. One typical application is cleaning exhaust air for the desulphurisation of gases in power stations. The CE400 trainer allows you to clearly demonstrate the complex theoretical fundamentals of this process in the laboratory.

The device is designed for the absorptive separation of carbon dioxide from an airflow. Water is used as solvent for absorbing the carbon dioxide. This ensures safe operation for the device user.



- 1 switch cabinet
- 2 absorption columns
- 3 U-tube manometer
- 4 desorption column
- 5 refrigeration system
- 6 cooling tank
- 7 process schematic

Principle of operation

The main components of the device are two absorption columns filled with Raschig rings. The previously-cooled air/CO₂ mixture is fed into the absorption columns from below. The solvent (water) trickles downwards in the opposite direction through the absorption columns, whereby the carbon dioxide is dissolved in the water. The water enriched with carbon dioxide in this way can then be regenerated in a desorption column and is then available for absorption again.

Instrumentation

The device is equipped with extensive instrumentation and control technology. All relevant flow rates, temperatures and pressures are continuously measured and displayed. The absorption columns are each equipped with a U-tube manometer to measure the differential pressures. You can check the success of the absorption process using the supplied gas analyser. Therefore you do not need any additional instrumentation in order to obtain quantifiable results.



Gas analyser for determining the oxygen content and carbon dioxide content.

About the product:





UNIVERSITY OF Hull

CE 400 is used in many universities worldwide, for example at the University of Hull (England).



A GUNT employee explains the functional principle of CE400 gas absorption to lecturers at the University of Hull.



Learning objectives

- investigation of the absorption process when separating gas mixtures in a packed column
- determination of pressure losses in the column
- representation of the absorption process in an operating diagram
- investigation of the variables influencing the effectiveness of absorption

CE 400

Gas absorption



Learning objectives/experiments

- investigation of the absorption process when separating gas mixtures in a packed column
- determination of pressure losses in the column
- representation of the absorption process in an operating diagram
- investigation of the variables influencing the effectiveness of absorption

Description

- separating a CO₂/air mixture by absorption in counterflow
- DURAN glass column with packed bed
- safe operation due to use of water as the solvent and non-hazardous gases
- regeneration of solvent by vacuum
- gas analysis with hand-held measuring unit

Absorption is used to remove one or more gaseous components from a gas flow using a solvent.

First of all, a CO₂ and air gas mixture is produced. It is possible to adjust the mixing ratio using valves. The flow rates of the gas components are displayed.

A compressor delivers the gas mixture into the lower section of the absorption column. In the column, part of the CO₂ is separated in the counterflow with the solvent. Water is used as the solvent. The CO₂ is absorbed by the downward flowing water. To separate the absorbed CO₂, the charged water is then fed from the lower section of the absorption column into a desorption column. As the pressure is reduced and the temperature is increased, the solubility of the CO₂ falls. A heater heats the water. A water jet pump generates negative pressure in the desorption column and causes the CO₂ gas to be emitted from the water. A pump then delivers the regenerated solvent back into the absorption column.

The water temperature can be controlled. Flow rate, temperature and pressure are continuously measured. The two-section column is equipped with connections to determine the pressure losses. The pressure loss in the respective sections can be displayed via two U-tube manometers. To evaluate the success of the process, the trainer includes outlets for taking gas and liquid samples. The gas samples can be analysed using the hand-held measuring unit supplied.

CE 400

Gas absorption

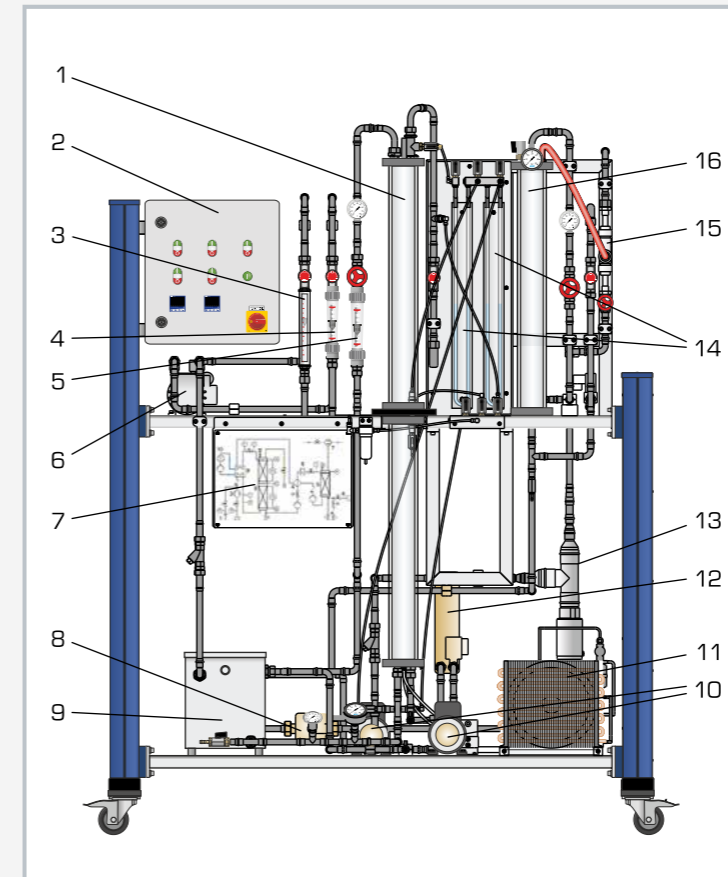

1 absorption column, 2 switch cabinet, 3 CO₂ flow meter, 4 air flow meter, 5 solvent flow meter, 6 compressor, 7 process schematic, 8 pump (cooling), 9 cooling tank, 10 pumps (absorption/desorption), 11 refrigeration system, 12 heat exchanger, 13 heater, 14 U-tube manometer, 15 water jet pump (vacuum), 16 desorption column

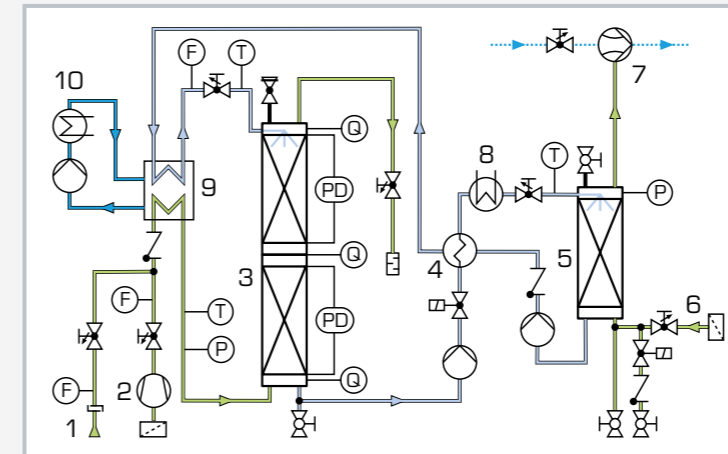

1 external CO₂ compressed gas cylinder with pressure reducing valve, 2 compressor (air), 3 absorption column, 4 heat exchanger, 5 desorption column, 6 air for desorption, 7 water jet pump (vacuum), 8 heater, 9 cooling tank, 10 refrigeration system; F flow rate, P pressure, PD differential pressure, T temperature, Q sampling point (gas)

Specification

- [1] separation of CO₂/air mixture by absorption in counterflow with water
- [2] production of gas mixture using CO₂ from compressed gas cylinder and ambient air
- [3] adjustment of mixing ratio using valves
- [4] compressor for delivering the gas mixture into the absorption column
- [5] DURAN glass absorption column (packed bed) and desorption column
- [6] continuous solvent regeneration in circuit with desorption column under vacuum
- [7] 1 pump for desorption column and 1 pump for returning solvent to absorption column
- [8] water temperature control with heater and refrigeration system
- [9] refrigerant R513A, GWP: 631

Technical data

- Absorption column
- height: 2x 750mm, inner diameter: 80mm
- Desorption column
- height: 750mm, inner diameter: 80mm
- 2 pumps (absorption/desorption)
- max. flow rate: 17,5L/min
 - max. head: 47m
- 1 pump (cooling)
- max. flow rate: 29L/min
 - max. head: 1,4m
- Compressor
- max. positive pressure: 0,5bar
 - max. flow rate: 34L/min
- Refrigeration capacity: 1432W at 5/32°C
- Refrigerant: R513A, GWP: 631
- filling volume: 600g
 - CO₂-equivalent: 0,4t

Measuring ranges

- flow rate:
 - ▶ 0,2...2,4Nm³/h (air)
 - ▶ 50...600L/h (solvent)
 - ▶ 0,4...5,4L/min (CO₂)
- temperature: 2x -200...100°C, 3x 0...120°C, 4x 0...60°C
- pressure: 1x 0...2,5bar, 1x -1...0,6bar
- differential pressure: 2x 0...250mmWC
- CO₂-content: 0...100vol%

230V, 50Hz, 1 phase
230V, 60Hz, 1 phase; 230V, 60Hz, 3 phases
UL/CSA optional
LxWxH: 1920x790x2300mm
Weight: approx. 290kg

Required for operation

CO₂ gas cylinder with pressure reducing valve
water connection, drain

Scope of delivery

- 1 trainer
- 1 hand-held measuring unit for gas analysis
- 1 set of hoses
- 1 set of instructional material

CE 405

Falling film absorption

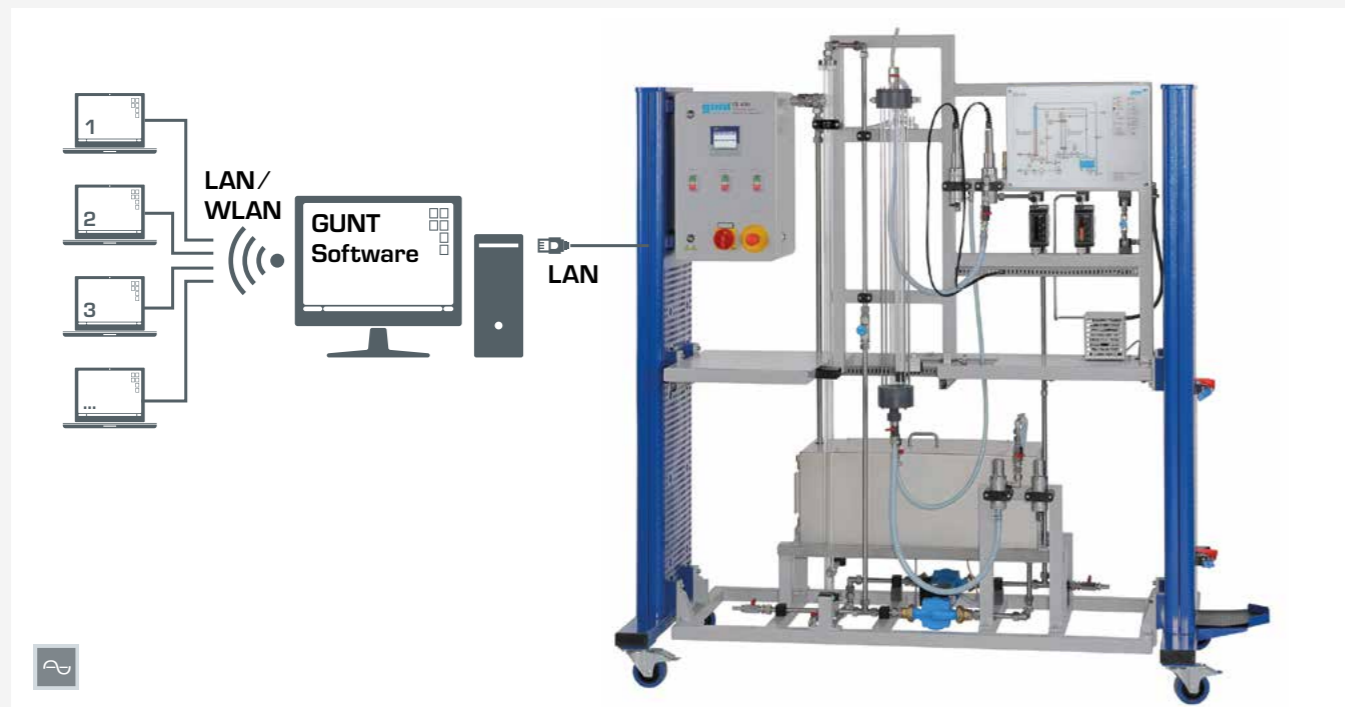

Network capable GUNT software: control and operation via 1 PC. Observation, acquisition, analysis of the experiments at any number of workstations via the customer's own LAN/WLAN network.

Description

- separation of oxygen by absorption
- continuous regeneration of the solvent with nitrogen by stripping
- safe operation due to use of water as the solvent and non-hazardous gases
- network capability: observe, acquire, analyse experiments via customer's own network

Absorption is used to remove one or more gaseous components from a gas flow using a solvent. Selective absorption is an important industrial process for the treatment of gas mixtures. CE 405 can be used to investigate the basic processes on the water-oxygen-nitrogen system.

A compressor supplies ambient air from below into the absorption column. Water flows down as a thin film at the edge of the absorption column. The air flows upwards centrally in the column. A portion of the air's oxygen is dissolved in the water film. The air flow exits the column at the top. The water containing the dissolved oxygen leaves the column at the bottom and flows into a tank. A pump supplies the water with the dissolved oxygen to the head of the desorption column.

The desorption column is a simple tube in which the water flows downwards. Nitrogen from a compressed gas cylinder enters at the base of the column. The nitrogen rises to the top in the form of dispersed bubbles in the water. The partial pressure of the oxygen in water is higher than the partial pressure in the gas phase (nitrogen). For this reason, a portion of the oxygen passes over from the water into the gas phase (stripping). This process leads to the water's absorbing capacity for oxygen increasing. A pump supplies the solvent regenerated in this way to the head of the absorption column. Transparent materials allow optimal observation of the processes in both columns.

Valves and flow meters make it possible to adjust the flow rates of air and solvent. The oxygen concentration and temperature are continuously measured both upstream and downstream of the absorption column and digitally displayed. The measured values can be transmitted simultaneously via LAN directly to a PC where they can be analysed using the GUNT software.

Learning objectives/experiments

- investigation of the absorption process during the separation of oxygen from an air flow in a falling film column
- balance of the process
- determination of the mass transfer coefficient depending on
 - ▶ volumetric air flow rate
 - ▶ flow rate of the solvent water
- regeneration of the solvent by stripping
- familiarisation with counterflow process

CE 405

Falling film absorption

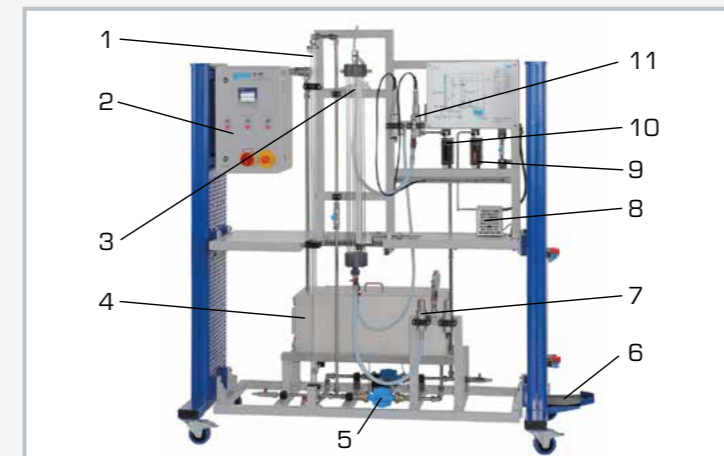

1 desorption column, 2 switch cabinet, 3 absorption column, 4 tank, 5 pump, 6 mounting for pressurised gas cylinder, 7 oxygen and temperature sensor downstream of absorption, 8 compressor, 9 flow meter (air), 10 flow meter (water), 11 oxygen and temperature sensor upstream of absorption

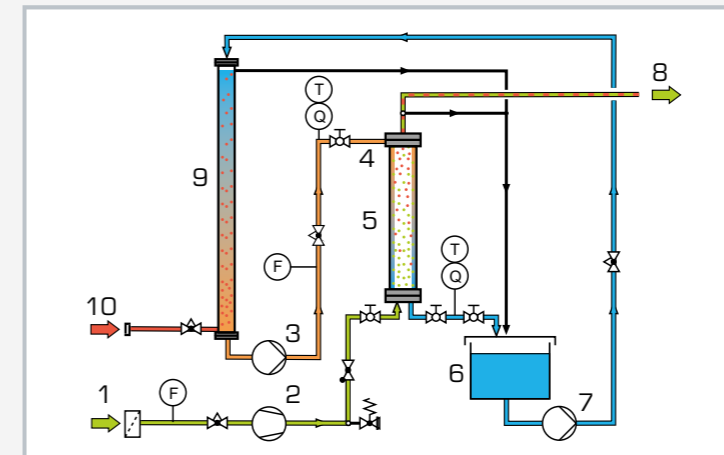

1 air inlet, 2 compressor, 3 pump, 4 regenerated solvent, 5 absorption column, 6 tank (solvent with dissolved oxygen), 7 pump, 8 air outlet, 9 desorption column, 10 nitrogen inlet (external); F flow rate, Q oxygen concentration, T temperature

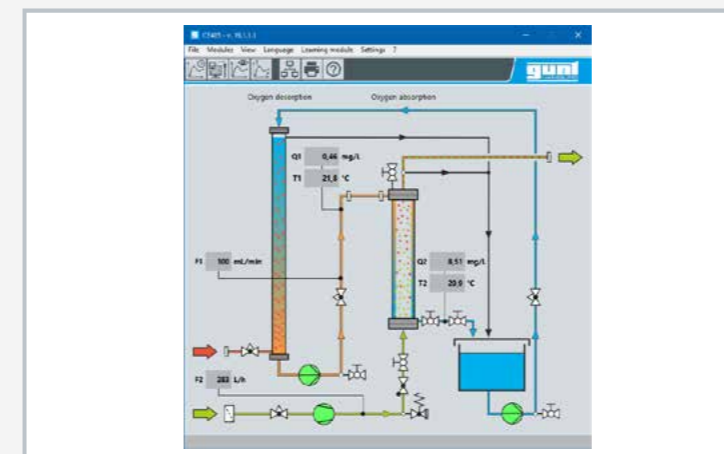

Software screenshot

Specification

- [1] transparent falling film column for the absorption of oxygen from the ambient air in water
- [2] continuous regeneration of the water (solvent) in a transparent desorption column by stripping with nitrogen
- [3] compressor supplies ambient air to the falling film column
- [4] 2 pumps supply water between the columns
- [5] valves and flow meters to adjust the flow rates of air and solvent
- [6] sensors rerecord oxygen concentration and temperature upstream and downstream of the absorption column
- [7] digital displays for all measuring values
- [8] network capability: observe, acquire, analyse experiments at any number of workstations with GUNT software via the customer's own LAN/WLAN network
- [9] data acquisition via customer's own network or via direct LAN connection with GUNT software under Windows 10

Technical data

Absorption column

- inner Ø x height: 32x890mm
- material: glass

Desorption column

- inner Ø x height: 24x1650mm
- material: PMMA

2 pumps

- max. flow rate: 58L/min each
- max. head: 3,7m each

Compressor

- max. positive pressure: 2bar
- max. flow rate: 23L/min

Tank, stainless steel: capacity: approx. 50L

Measuring ranges

- flow rate: 38...380mL/min (water)
- flow rate: 36...360NL/h (air)
- temperature: 2x 0...50°C
- oxygen concentration: 2x 0...20mg/L

230V, 50Hz, 1 phase; 230V, 60Hz, 1 phase
120V, 60Hz, 1 phase; UL/CSA optional
LxWxH: 1930x790x1980mm
Weight: approx. 135kg

Required for operation

nitrogen gas cylinder with pressure reducing valve
PC with Windows recommended

Scope of delivery

- 1 trainer
- 1 set of accessories
- 1 GUNT software
- 1 set of instructional material

CE 540

Adsorptive air drying



Learning objectives/experiments

- fundamental principle of adsorption and desorption
- investigation of the variables influencing adsorption and desorption
 - ▶ air flow rates
 - ▶ air humidity and temperature
 - ▶ bed height of adsorbent
- depiction of the processes in a h-w diagram
- plotting of breakthrough curves and determination of breakthrough time

Description

- adsorptive drying of humid air
- continuous process with regeneration of adsorbent
- transparent columns and adsorbent with indicator to observe the mass transfer zone
- GUNT software with control functions and data acquisition

The CE 540 has been specifically designed to enable the complex theoretical principles of adsorption processes to be explained clearly and comprehensibly by means of experimentation.

A compressor draws in ambient air. The air flows through the water bath of a humidifier and thereafter has a relative humidity of 100%.

Before the air flows from below into the adsorption column, its relative humidity and temperature are set using a heater. The humid air flows through the adsorbent (silica gel), which is placed as a fixed bed inside a transparent column. The quantity of humidity contained in the air is adsorbed in the process. The adsorbent contains an indicator. The colour of this indicator shows the position of the mass transfer zone (MTZ). The air dried in this way exits the column and flows out into the open.

To regenerate the adsorbent, ambient air is drawn in by a second compressor. The air is heated and flows from above into the column. This desorption process can also be observed through the transparent column. The trainer enables simultaneous investigation of the adsorption and desorption processes.

Once the capacity of the adsorbent in one column is exhausted, the humid air is fed through a second column with regenerated adsorbent to dry it.

A circuit system featuring a pump and a refrigeration system is provided to adjust the temperature of the water bath in the humidifier. The temperature and humidity of the air being dried are adjusted by software. The flow rates of the two air flows can be adjusted by valves.

By recording the relative humidities and temperatures at all relevant points, the two processes can be fully balanced. The measured values are recorded by software. The software permits the adsorption and desorption processes to be depicted in a h-w diagram and enables breakthrough curves to be plotted.

CE 540

Adsorptive air drying

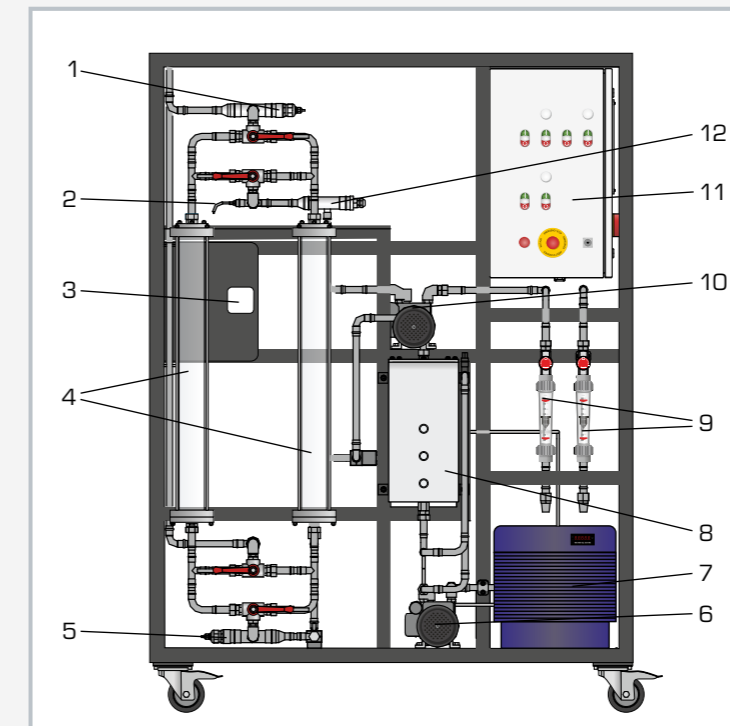

1 dried air humidity and temperature sensor, 2 regenerative air temperature sensor, 3 ambient air humidity and temperature sensor, 4 adsorption columns, 5 humidified feed air humidity and temperature sensor, 6 feed air compressor, 7 refrigeration system, 8 humidifier (water bath), 9 regenerative air and feed air flow rate sensors, 10 regenerative air compressor, 11 switch cabinet with controls, 12 regenerative air heater

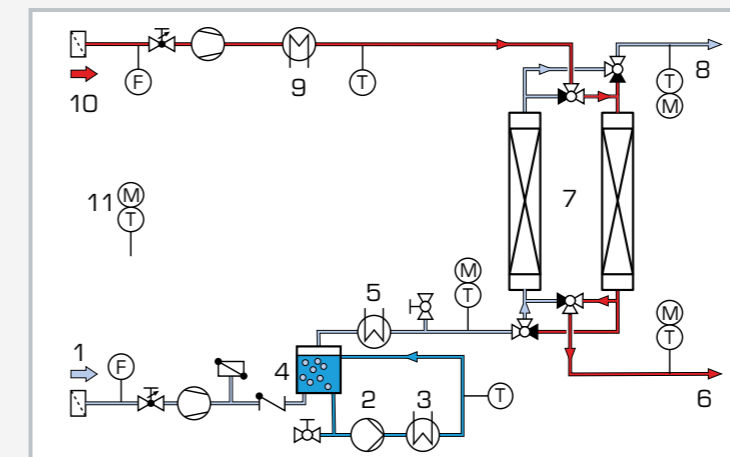

1 feed air (blue), 2 humidifier pump, 3 refrigeration system, 4 humidifier (water bath), 5 heater, 6 charged regenerative air (red), 7 adsorption columns, 8 dried air, 9 heater, 10 air for regeneration, 11 ambient air; M humidity, T temperature, F flow rate

Specification

- [1] continuous adsorptive air drying
- [2] 2 columns for alternating charging and regeneration of the adsorbent
- [3] observation of mass transfer zone by using transparent columns and adsorbent with indicator
- [4] 2 compressors to deliver the feed air and regenerative air out of the ambient atmosphere
- [5] humidification of the feed air by flowing through a water bath
- [6] circular system with pump and refrigeration system to adjust the water bath temperature
- [7] adjustment of relative humidity and temperature of feed air by heater
- [8] heater for temperature adjustment of the regenerative air
- [9] adjustment of regenerative air and feed air flow rates by valves
- [10] GUNT software with control functions and data acquisition via USB under Windows 8.1, 10

Technical data

- 2 columns
- Ø approx. 80mm
 - height: approx. 800mm
- 2 compressors
- max. positive pressure: 1 bar
 - max. flow rate: 8m³/h
- Humidifier pump
- max. flow rate: 600L/h
 - max. head: 1,5m
- Refrigeration system
- refrigeration capacity: 395W at temperature difference 10K / 250L
- 2 electric air heaters
- power output (feed air): 160W
 - power output (regeneration): 2x 250W

Measuring ranges

- flow rate: 2x 0...10Nm³/h
- temperature: 3x 0...50°C; 1x 0...200°C, 1x -25...125°C (air)
- rel. humidity: 4x 0...100%
- temperature: 1x 0...50°C (water)

230V, 50Hz, 1 phase
230V, 60Hz, 1 phase; 230V, 60Hz, 3 phases
UL/CSA optional
LxWxH: 1390x750x1890mm
Weight: approx. 150kg

Required for operation

PC with Windows

Scope of delivery

- 1 trainer
- 1 packing unit of silica gel E
- 1 set of tools
- 1 GUNT software + USB cable
- 1 set of instructional material

Overview

CE 583 Adsorption

Adsorptive water treatment in continuous operation

Adsorption on activated carbon is an effective and often practised alternative to the removal of non-biodegradable organic substances, such as chlorinated hydrocarbons. Our CE 583 device allows you to demonstrate the fundamentals of this process in continuous operation and therefore under very practical conditions.

The main components of this device are two series-connected adsorbers which are filled with granulated active carbon. The first adsorber is equipped with sampling valves so that you can determine concentration profiles. Concentration profiles are essential for understanding adsorption.

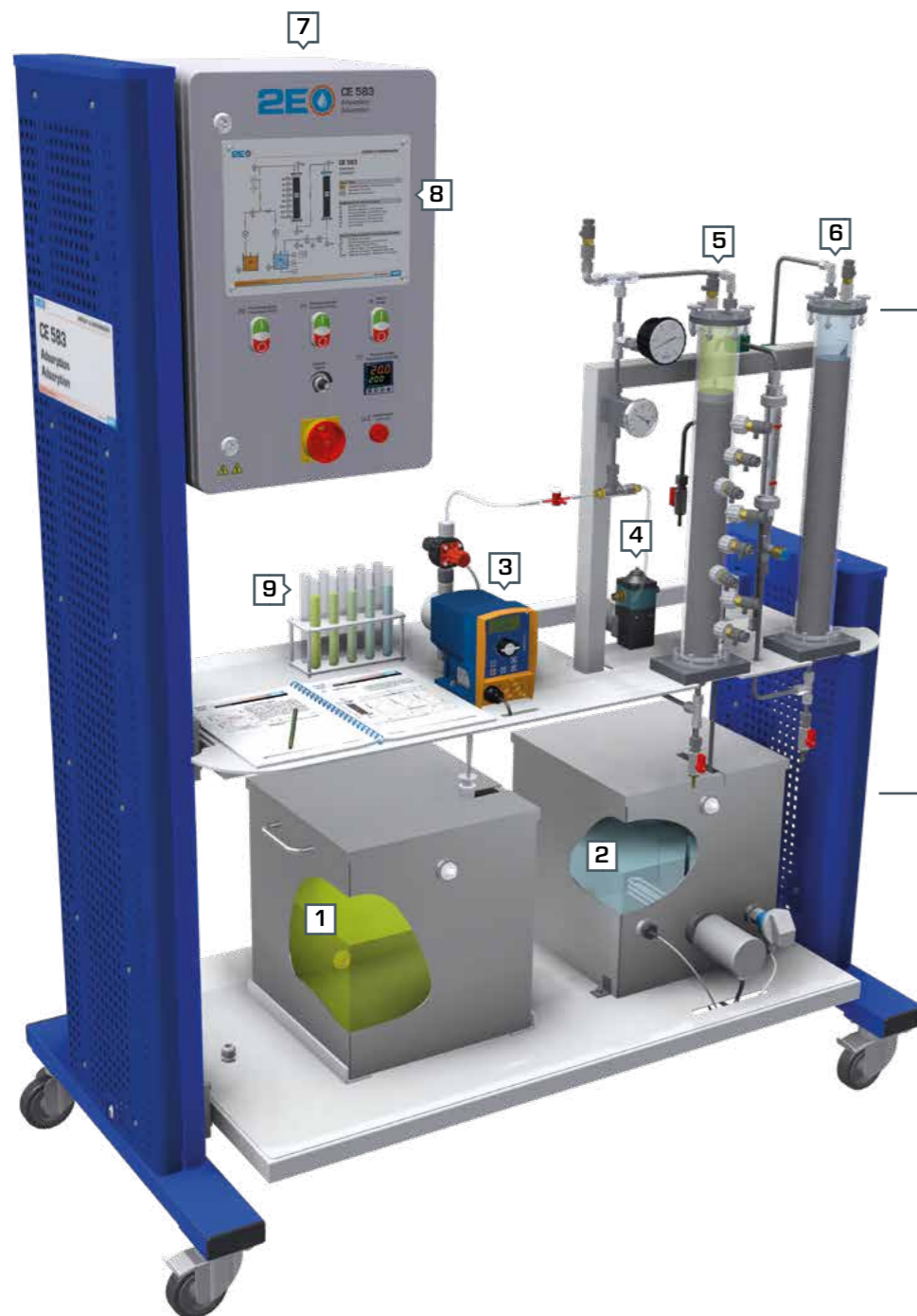

- 1 adsorbate concentrate
- 2 treated water
- 3 metering pump
- 4 circulation pump
- 5 first adsorber
- 6 second adsorber
- 7 switch cabinet
- 8 process schematic
- 9 test tubes for sampling

i Adsorbate

Adsorbate refers to the substance dissolved in the water which is to be eliminated by adsorption

Principle of operation

Treated water is circulated through both adsorbers. A metering pump injects concentrated adsorbate solution into the inlet area of the first adsorber in the circuit. The metering pump allows very precise adjustment of the flow rate. This allows you to adjust the desired feed concentration of the adsorbate very precisely. The second adsorber ensures that the circulated water doesn't contain any more adsorbate even at full breakthrough of the first adsorber. This ensures a constant adsorbate concentration in the inlet of the first adsorber, even in long-term experiments.

Temperature control

The device is equipped with a temperature control system. This allows you to study how water temperature influences the adsorption process.

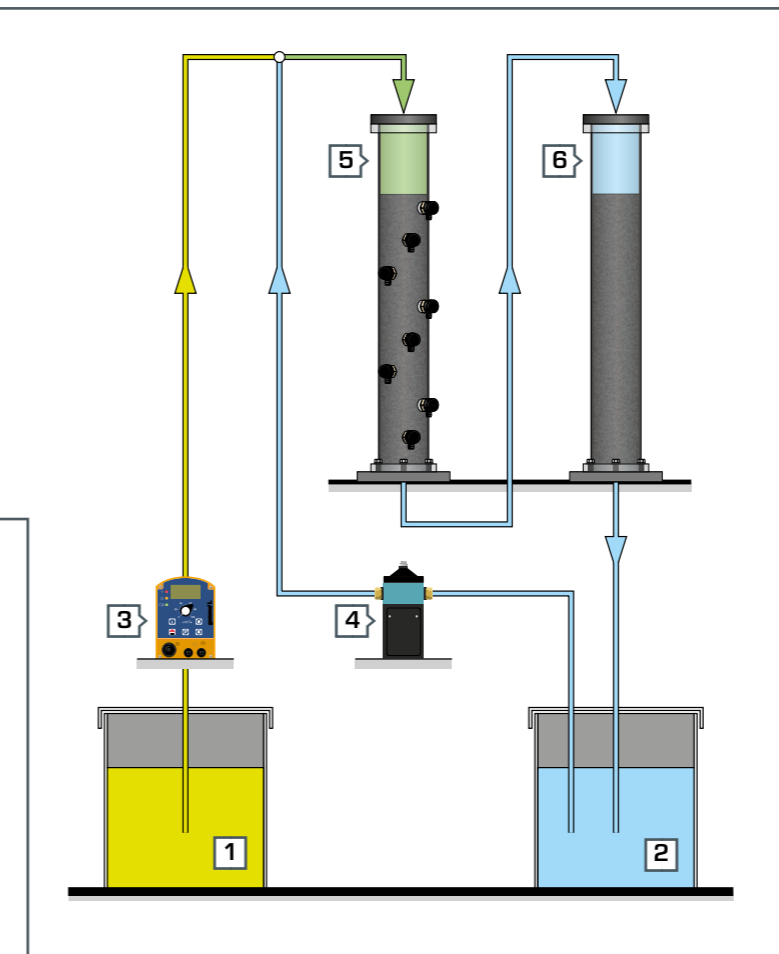

About the product:



i Our recommendation

You can deliver a particularly impressive demonstration of adsorption when you use a water-soluble and adsorbable dye as the adsorbate. Such substances include methylene blue or fluoresceine.

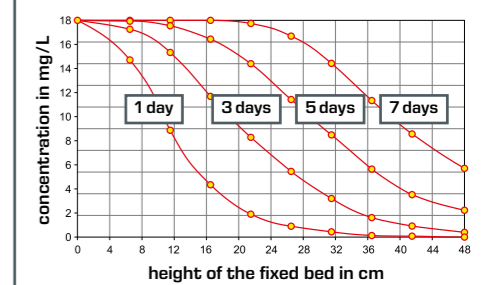

Excerpt from the CE 583 manual:
concentration profiles at various times for methylene blue

Learning objectives

- recording of concentration profiles
- recording of breakthrough curves
- relationship between concentration profiles and breakthrough curves
- determining the mass transfer zone
- an adsorber's efficiency and mass balance
- predicting breakthrough curves
- scale-up of the results to industrial scale
- factors influencing the adsorption
 - ▶ contact time
 - ▶ temperature
 - ▶ mode of operation

CE 583
Adsorption**Learning objectives/experiments**

- recording of concentration profiles
- recording of breakthrough curves
- relationship between concentration profiles and breakthrough curves
- determining the mass transfer zone
- an adsorber's mass balance
- an adsorber's efficiency
- predicting breakthrough curves
- scale-up of the results to industrial scale
- detection of the following influencing factors
 - ▶ contact time
 - ▶ temperature
 - ▶ mode of operation

Description

- adsorption of dissolved substances on activated carbon
- concentration profiles and breakthrough curves
- determination of the mass transfer zone
- influence of the temperature and the contact time on adsorption
- practical experiments in laboratory scale

CE 583 demonstrates the removal of dissolved substances by adsorption. During adsorption the substances dissolved in the raw water are called adsorbate.

A pump transports the water from a tank in a circuit with two adsorbers filled with activated carbon. The pump transports treated water to the first adsorber. A concentrated adsorbate solution is added to the treated water flow using a metering pump.

The raw water produced in this way enters the adsorber and flows through the activated carbon fixed bed. Here the adsorbate adsorbs on the activated carbon. To remove any quantities of adsorbate still present from the water, the water then flows through a second adsorber (safety adsorber). The treated water is returned to the feed line of the first adsorber where concentrated adsorbate solution is added once again. This creates a closed water circuit.

The flow rates of both pumps can be adjusted. Thereby the following parameters can be varied:

- concentration of the adsorbate in the raw water
- contact time of the raw water with the activated carbon

The water temperature can be controlled. This allows for the temperature effect of the adsorption to be investigated. Flow rate, temperature and pressure are continuously measured. Sampling points are arranged in such a way that breakthrough curves and concentration profiles can be plotted.

Analysis technology is required to evaluate the experiments. The choice of analysis technology depends on the adsorbate used. Methylene blue can e.g. be used as adsorbate. The concentration of methylene blue can be determined using a photometer.

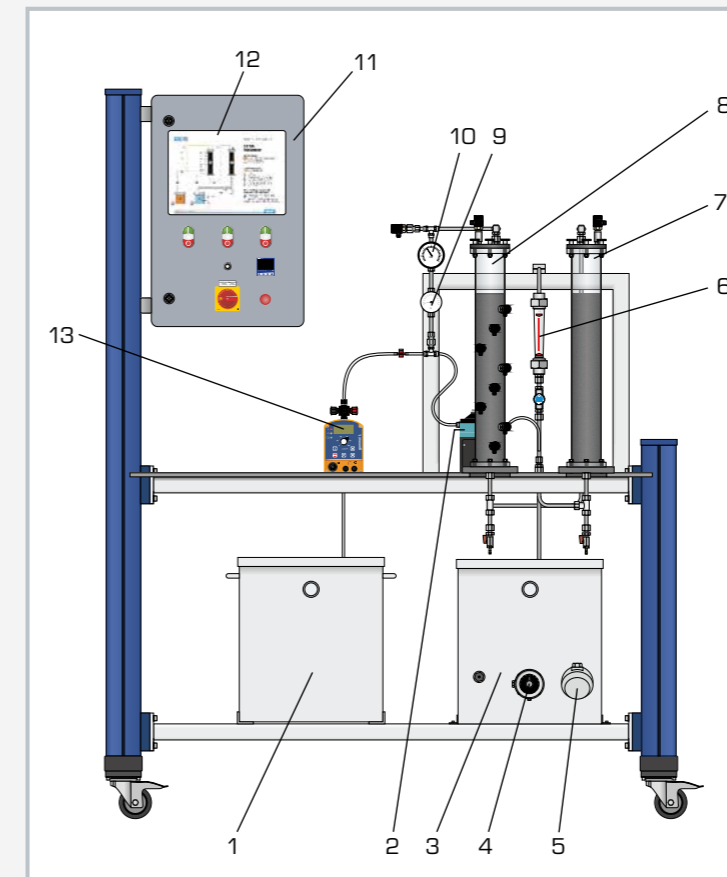
CE 583
Adsorption

1 adsorbate solution tank, 2 circulation pump, 3 treated water tank, 4 heater, 5 temperature sensor, 6 flow meter, 7 safety adsorber, 8 adsorber, 9 thermometer, 10 manometer, 11 switch cabinet, 12 process schematic, 13 metering pump

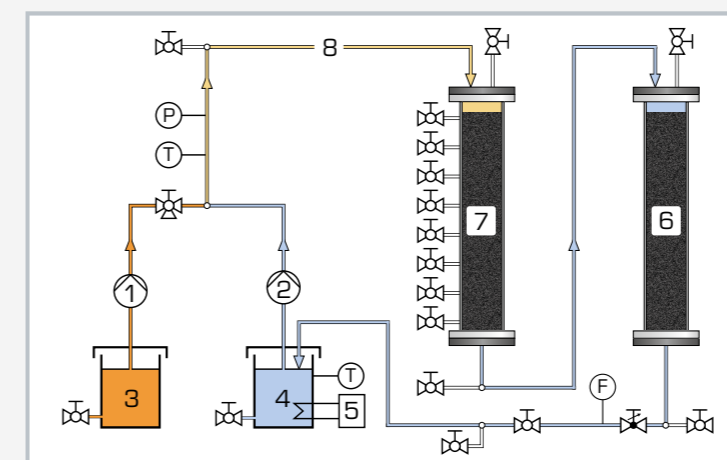

1 metering pump, 2 circulation pump, 3 concentrated adsorbate solution, 4 treated water, 5 heater, 6 safety adsorber, 7 adsorber, 8 raw water; F flow rate, P pressure, T temperature

Specification

- [1] 2 adsorbers with activated carbon filling
- [2] adsorber with 8 sampling points
- [3] safety adsorber for closed water circuit
- [4] continuous process
- [5] metering pump for concentrated adsorbate solution
- [6] pump for recirculating the treated water
- [7] water temperature control
- [8] digital temperature indication
- [9] flow rate adjustable
- [10] change of adsorbate concentration and contact time

Technical data

Adsorber and safety adsorber

- inner diameter: each 60mm
- height: each 600mm
- capacity: each 1700cm³

Tanks

- treated water: 45L
- adsorbate solution: 45L

Circulation pump

- max. flow rate: 180L/h
- max. head: 10m

Metering pump

- max. flow rate: 2,1L/h
- max. head: 160m

Heater

- max. power: 500W

Measuring ranges

- flow rate: 0...60L/h
- temperature: 0...60°C
- pressure: 0...2,5bar

230V, 50Hz, 1 phase
230V, 60Hz, 1 phase; 120V, 60Hz, 1 phase
UL/CSA optional
LxWxH: 1500x790x1900mm
Weight: approx. 180kg

Required for operation

water connection, drain
methylene blue (recommendation)

Scope of delivery

- 1 trainer
- 1 packing unit of activated carbon
- 1 set of test tubes
- 1 set of tools
- 1 set of instructional material

Basic knowledge

Crystallisation

Crystallisation is a unit operation in thermal process engineering, and is mainly used for separation and cleaning but also for shaping substances. A characteristic feature of crystallisation is the formation of a new solid phase (crystallisate). The crystallisate can develop from a solution, a liquefied material or vapour. In industrial process and chemical engineering, the main focus is on technical mass crystallisation from liquid phases, particularly solutions. Crystallisation plays a crucial role in the production of crystalline bulk goods such as sugar, cooking salt and fertilisers from aqueous solutions.

A solvent (e.g. water) is able to dissolve a certain quantity of a material (salt) at a fixed temperature. As long as the solvent's maximum capacity to absorb the dissolved substance (saturation concentration) is not reached, there is only a single liquid phase. If the saturation concentration is exceeded, the dissolved substance begins to crystallise. This results in a second, solid phase – the crystallisate.

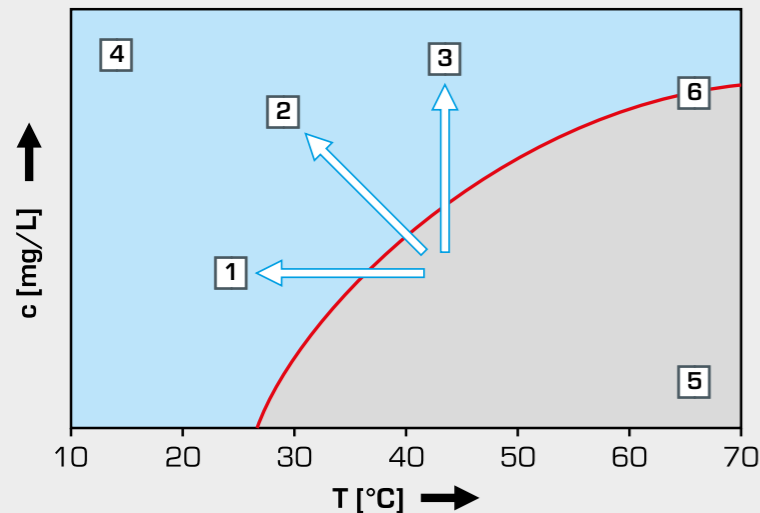

Simplified illustration of crystallisation unit operations in temperature/solubility diagram:

- T temperature
c dissolved material
1 cooling crystallisation
2 vacuum crystallisation
3 evaporation crystallisation
4 oversaturated solution
5 undersaturated solution
6 solubility curve

Crystallisation can be achieved using three unit operations:

■ Cooling crystallisation

If solubility is highly dependent on temperature, the saturation concentration of the solute can be exceeded by cooling.

■ Evaporation crystallisation

Part of the solvent is evaporated until the dissolved quantity of material in the remaining solution exceeds the saturation concentration. This unit operation is used if solubility is only slightly dependent on temperature.

■ Vacuum crystallisation

This unit operation uses a combination of the effects described before. Relaxation in a vacuum evaporates part of the solution. The removal of the latent heat of evaporation has a cooling effect on the solution. This unit operation is particularly beneficial for temperature-sensitive substances as evaporation in a vacuum occurs at lower temperatures.

Basic knowledge

Membrane separation processes

Compared to filtration, membrane separation processes remove much smaller substances, such as viruses and dissolved ions, from the water. The driving forces of the separation process are differences in concentration or pressure between the two sides of the membrane. The following membrane separation processes are used in water treatment:

Microfiltration

Ultrafiltration

Nanofiltration

Reverse osmosis

The pressure difference – the so-called transmembrane pressure – increases in the sequence indicated above. At the same time the separation limit – that is, the size of the smallest separable substances – decreases. The treated water is termed permeate, and the retained portion of the raw water is retentate.

Reverse osmosis

Reverse osmosis is particularly important. This unit operation enables high purity water to be produced. It is widely used for many different processes in industry and for desalination of sea water.

To understand the reverse osmosis, the osmosis first has to be explained by an example (figure). Two salt solutions with differing concentrations are separated by a semi-permeable membrane. The membrane is only permeable to water molecules. In trying to equalise concentrations on either side, water flows from left to right through the membrane. The water level rises on the right side until a state of equilibrium is established, the – so called – osmotic equilibrium. The same salt concentration now

prevails on both sides of the membrane. The resultant hydrostatic pressure difference between the two sides of the membrane is termed the osmotic pressure.

To reverse the direction of flow of the water (reverse osmosis), the osmotic pressure must be overcome. To do so, a pressure greater than the osmotic pressure is applied to the right side of the membrane. The water then flows from right to left through the membrane. The retentate is produced on the right hand side, and the permeate on the left. In the applications mentioned transmembrane pressures up to 100 bars can be required.

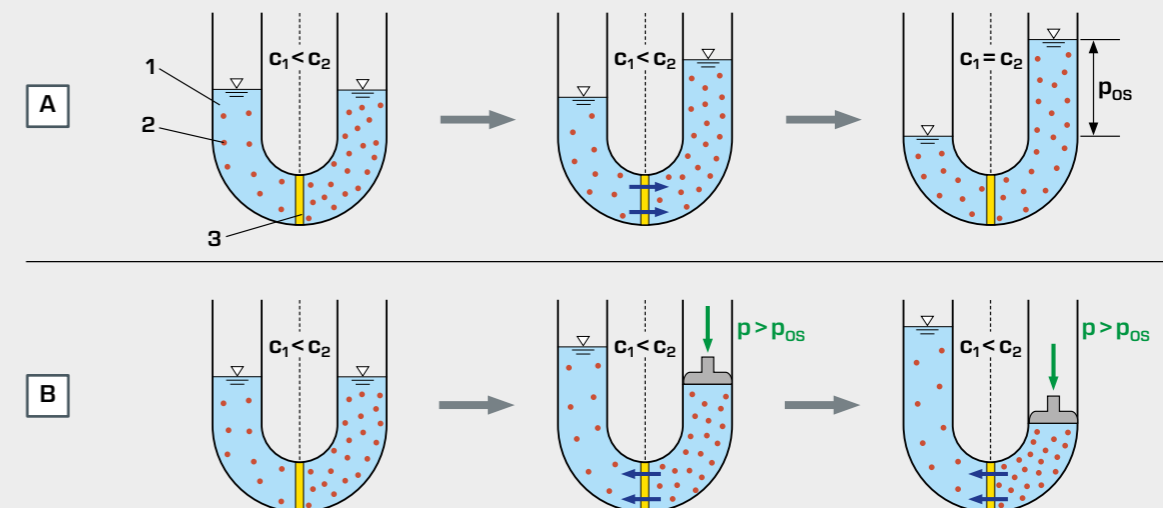

Fundamental principle of osmosis (A) and reverse osmosis (B):

- 1 water, 2 salt ions, 3 semi-permeable membrane;
p pressure, p_{os} osmotic pressure, c_1 salt concentration on the left side of the membrane, c_2 salt concentration on the right side of the membrane

CE 520

Cooling crystallisation



Description

- crystallisation from solutions
- investigation of crystal growth in a fluidised bed
- transparent materials for observation of processes

Crystallisation enables dissolved substances from solutions to be transformed into a solid and separated.

This trainer has been developed in cooperation with the **Chair of the Thermal Process Technology at the Martin-Luther University, Halle-Wittenberg (Prof. Dr. Ulrich)**.

A pump delivers a saturated potassium sulphate solution in a circuit with a tank. To prevent premature crystallisation, the solution is heated above saturation temperature using a heating circuit. Both circuits are connected by two heat exchangers. A small amount of this undersaturated solution is fed through the crystallisation cell as a bypass. To crystallise this part of the solution, it is cooled by cooling water using two heat exchangers. Reducing the temperature converts the solution into an oversaturated, metastable state.

The crystallisation cell is a tube fitted with porous filter media at both the inlet and outlet. The removable cell can be opened to allow the addition of seed crystals. The porous filter media are selected in a way that the crystals can't escape from the cell. The flow conditions cause a fluidised bed in the cell. The dissolved potassium sulphate crystallises out of the metastable solution at the seed crystals. The crystals grow. The growth rate can be determined by weighing the crystals before and after the experiment and by measurement of time.

A stirred tank with heat exchanger is available to prepare a saturated potassium sulphate solution. The temperatures in the two tanks and the temperature required in the bypass for crystallisation are recorded and controlled using sensors.

A drying chamber, a balance, a screening machine and a microscope are recommended for evaluating the experiments. Potassium sulphate is not included.

Learning objectives/experiments

- fundamental principle of cooling crystallisation
- investigation of the factors influencing crystal growth
 - ▶ oversaturation
 - ▶ saturation time

CE 520

Cooling crystallisation

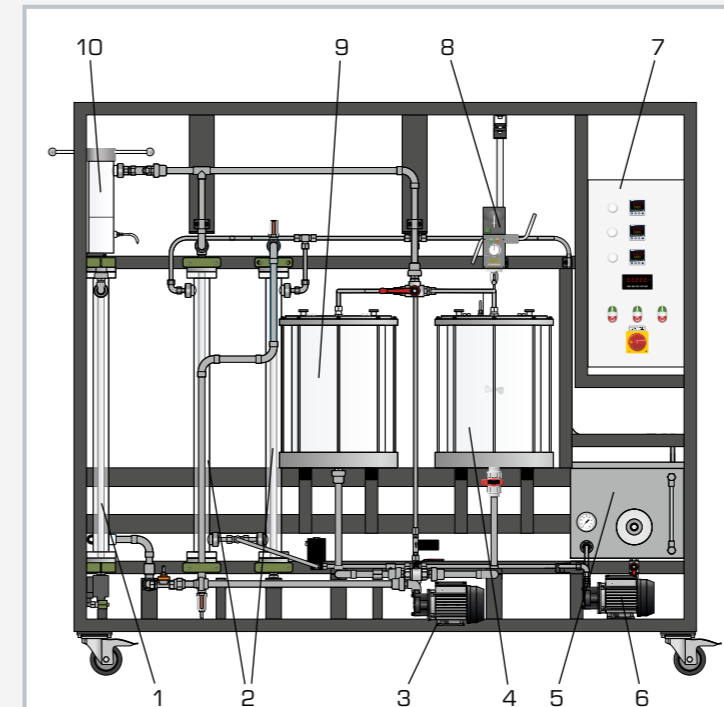

1 heat exchanger for cooling, 2 heat exchanger for heating, 3 solution pump, 4 tank for preparation of saturated solution, 5 tank with heater and thermostat, 6 heating circuit pump, 7 switch cabinet, 8 stirring machine, 9 tank for undersaturated solution, 10 crystallisation cell

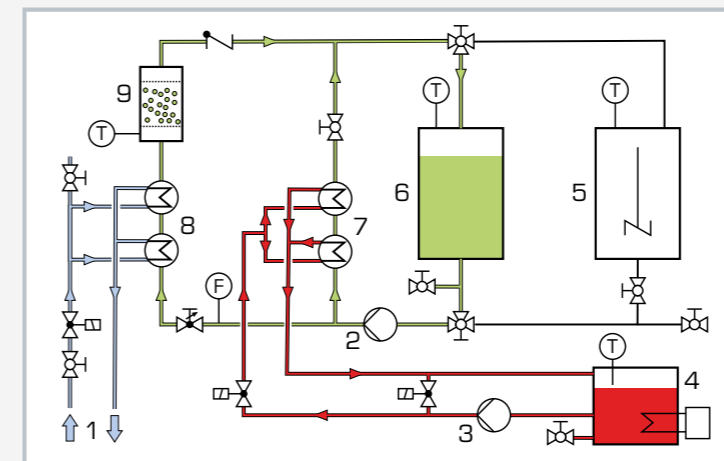

1 external cooling water, 2 solution pump, 3 heating circuit pump, 4 tank with heater and thermostat, 5 stirred tank for preparation of saturated solution, 6 tank for undersaturated solution, 7 heat exchanger for heating, 8 heat exchanger for cooling, 9 crystallisation cell; T temperature, F flow rate

Specification

- [1] crystallisation from solutions in fluidised bed
- [2] stirred tank for preparation of a saturated solution
- [3] circuit for undersaturated solution with tank, 2 heat exchangers for heating and pump
- [4] bypass for oversaturated solution with crystallisation cell and 2 heat exchangers for cooling
- [5] removable and fillable crystallisation cell, PMMA
- [6] heating circuit with pump, tank, heater and thermostat
- [7] adjustment of flow rate in bypass using valves
- [8] measurement and control of temperatures in stirred tank, tank for undersaturated solution and in crystallisation cell

Technical data

Tanks

- stirred tank: approx. 25L
- for undersaturated solution: approx. 25L
- heating circuit: approx. 32L

Pump (solution)

- max. flow rate: approx. 21L/min
- max. head: approx. 38m

Pump (heating circuit)

- max. flow rate: approx. 6L/min
- max. head: approx. 9m

Crystallisation cell

- diameter: approx. 40mm
- height: approx. 80mm

Heater power output: approx. 2kW

Measuring ranges

- temperature: 3x 0...100°C, 1x 0...80°C
- flow rate: 1x 0...12L/min

230V, 50Hz, 1 phase
230V, 60Hz, 1 phase
230V, 60Hz, 3 phases
UL/CSA optional
LxWxH: 2000x800x1850mm
Weight: approx. 255kg

Required for operation

cold water connection: min. 3bar, max. 15°C; drain

Scope of delivery

- 1 trainer
- 1 hose
- 1 set of tools
- 1 set of instructional material

CE 530

Reverse osmosis



The illustration shows: supply unit (left) and trainer (right), screen mirroring is possible on different end devices

Description

- **membrane separation process for obtaining solvent from a salt solution**
- **spiral wound membrane module for separation**
- **plant control using an integrated PLC**
- **integrated router for operation and control via an end device and for screen mirroring on additional end devices: PC, tablet, smartphone**

This trainer has been developed in cooperation with the **Institute for Thermal Process Engineering at the TU Hamburg-Harburg**. A solution of NaCl in a defined concentration (up to 3,2% max.) is mixed in a tank complete with a stirring machine. A pump delivers the solution to the spiral wound membrane module. The pump generates the necessary pressure for separation.

The spiral wound membrane module consists of multiple membrane envelopes. A membrane envelope is made up of two membranes with a porous spacer between them. The membrane envelope is sealed on three sides and on its fourth, open, side is connected to the perforated permeate collecting tube. There are other spacers between the envelopes to ensure axial flow of the salt solution. The spacers together with the membrane envelopes are wound spirally around the permeate collecting tube.

The salt solution arrives at the front face of the module and flows axially between the envelopes. The semi-permeable membrane is permeable to water (permeate) but not to dissolved NaCl. The applied pressure forces the water through the membrane into the envelopes. In the envelope the water flows spirally towards the permeate collecting tube and exits the module in an axial direction. As a result of the water being removed, the solution is concentrated as it travels through the module. It exits the module as retentate and is returned to the raw water tank. The permeate is collected in a separate tank. In order to check the success of the separation, salt concentrations in the raw water, retentate and permeate are recorded by measuring the respective conductivity values.

The trainer is controlled by the PLC via touch screen. The pressure and flow rate can be adjusted by valves. By means of an integrated router, the trainer can alternatively be operated and controlled via an end device. The user interface can also be displayed on additional end devices (screen mirroring). Via the PLC, the measured values can be stored internally. Access to stored measured values is possible from end devices. Via direct LAN connection the measured values can also be transmitted to a PC where they can be analysed using the GUNT software.

Learning objectives/experiments

- assembly, cleaning and conservation of membrane modules
- fundamental principle of reverse osmosis
 - ▶ Van't Hoff's law
- permeate flow rate and retention dependent on
 - ▶ pressure
 - ▶ salt concentration in raw water
 - ▶ yield
- determination of diffusion coefficients
- screen mirroring: mirroring of the user interface on end devices
 - ▶ menu navigation independent of the user interface shown on the touch screen
 - ▶ different user levels available on the end device: for observing the experiments or for operation and control

CE 530

Reverse osmosis

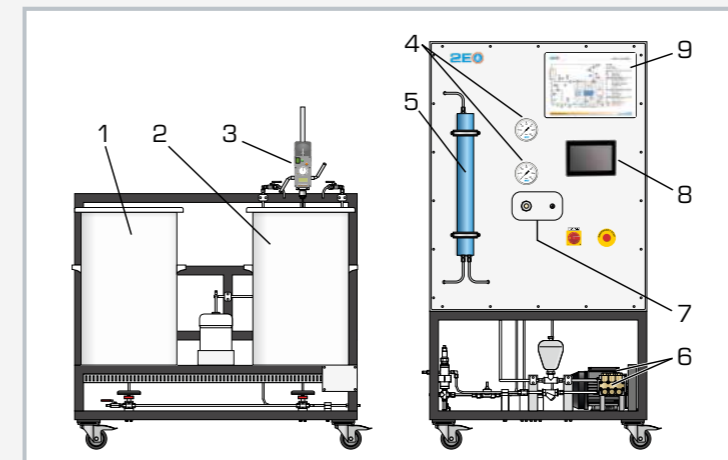

1 rinsing water tank (distilled water), 2 raw water tank (salt solution), 3 stirring machine, 4 manometer, 5 spiral wound membrane module, 6 pump with motor, 7 valves, 8 PLC with touch screen, 9 process schematic

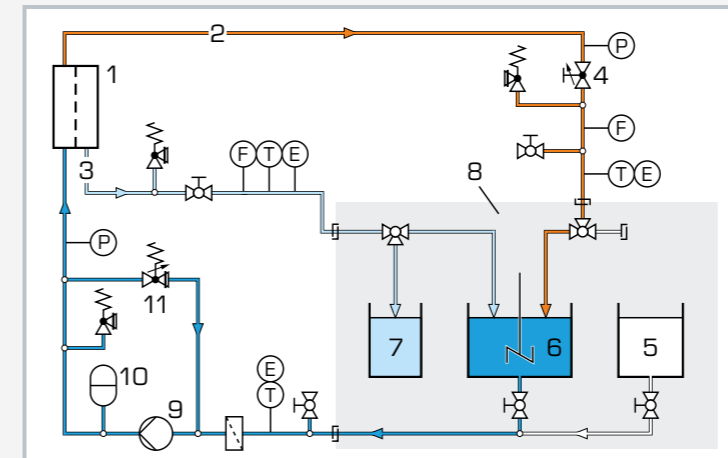

1 spiral wound membrane module, 2 retentate, 3 permeate, 4 retentate valve, 5 rinsing water (distilled water), 6 raw water (salt solution), 7 permeate, 8 supply unit, 9 pump, 10 pulsation damper, 11 overflow valve; P pressure, F flow rate, T temperature, E conductivity

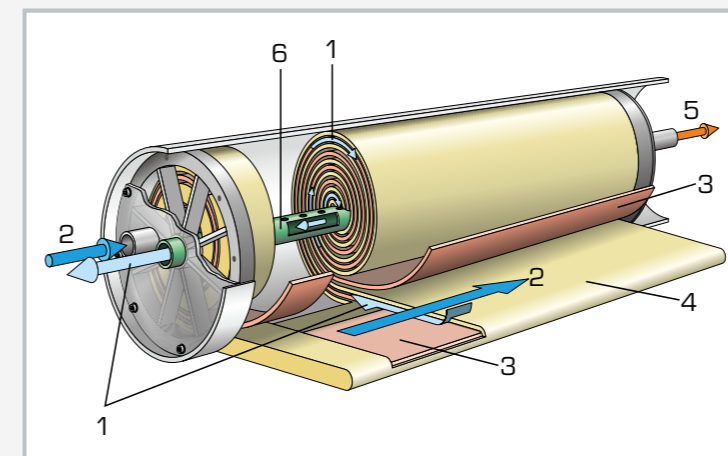

Spiral wound membrane module: 1 permeate, 2 raw water, 3 spacer, 4 membrane envelope, 5 retentate, 6 permeate collecting tube

Specification

- [1] removal of solvent from a salt solution using reverse osmosis
- [2] polyamide spiral wound membrane module
- [3] piston pump with pulsation damper for pressure generation
- [4] overflow valve to adjust the pressure upstream of the membrane module
- [5] valve to adjust the retentate flow rate
- [6] safety cutout to protect the pump against dry running
- [7] plant control with PLC via touch screen
- [8] integrated router for operation and control via an end device and for screen mirroring: mirroring of the user interface on up to 5 end devices
- [9] data acquisition via PLC on internal memory, access to stored measured values via WLAN with integrated router/ LAN connection to customer's own network
- [10] GUNT software for data acquisition via LAN under Windows 8.1, 10

Technical data

PLC: Eaton XV-303

Spiral wound membrane module

■ active area: 1,2m²

■ raw water flow rate: max. 1,4m³/h

■ length: approx. 533mm, Ø approx. 61mm

Piston pump

■ max. flow rate: approx. 585L/h

■ max. pressure: approx. 140bar

max. operating pressure: 58bar

Stirring machine

■ power consumption: 130W

■ speed: 50...1000min⁻¹

Tanks

■ raw water (salt solution, 3,2% max.): approx. 110L

■ rinsing water (distilled water): approx. 110L

■ permeate: approx. 5L

Measuring ranges

■ flow rate: 0,5...7,5L/min (retentate), 0,05...1,8L/min (permeate)

■ temperature: 3x 0...60°C

■ pressure: 4x 0...100bar (2x manometer, 2x sensor)

■ conductivity: 3x 0...200mS/cm

230V, 50Hz, 1 phase; 230V, 60Hz, 1 phase

120V, 60Hz, 1 phase; UL/CSA optional

LxWxH: 1250x1050x2100mm (trainer)

LxWxH: 1500x1050x1400mm (supply unit)

Total weight: approx. 290kg

Required for operation

water connection, drain, sodium chloride (NaCl), distilled water, sodium disulfite (conservation of the membrane module), caustic soda, hydrochloric acid, PC with Windows recommended

Scope of delivery

trainer, supply unit, membrane, conservation tank, 1 set of accessories, 3x conductivity meter, 1 GUNT software, 1 set of instructional material

Basic knowledge

Liquid-liquid extraction

Liquid-liquid extraction involves using a liquid solvent to remove a liquid component from a liquid mixture. The component dissolves preferably in the solvent. Applications of this process include removal of vitamins from aqueous solutions and aromatic compounds from crude oil fractions.

In the simplest case, three components are involved:

- transition component
- solvent
- carrier liquid

The transition component is combined with the carrier liquid as the initial mixture (feed). If the initial mixture and the solvent are mixed together, the transition component is transferred into the

solvent. After settling, two phases are obtained: the solvent with the dissolved transition component (extract) and the carrier liquid. The requirement for this is that the solubility of the transition component in the solvent is higher than in the carrier liquid. In turn, the carrier liquid should be almost insoluble in the solvent.

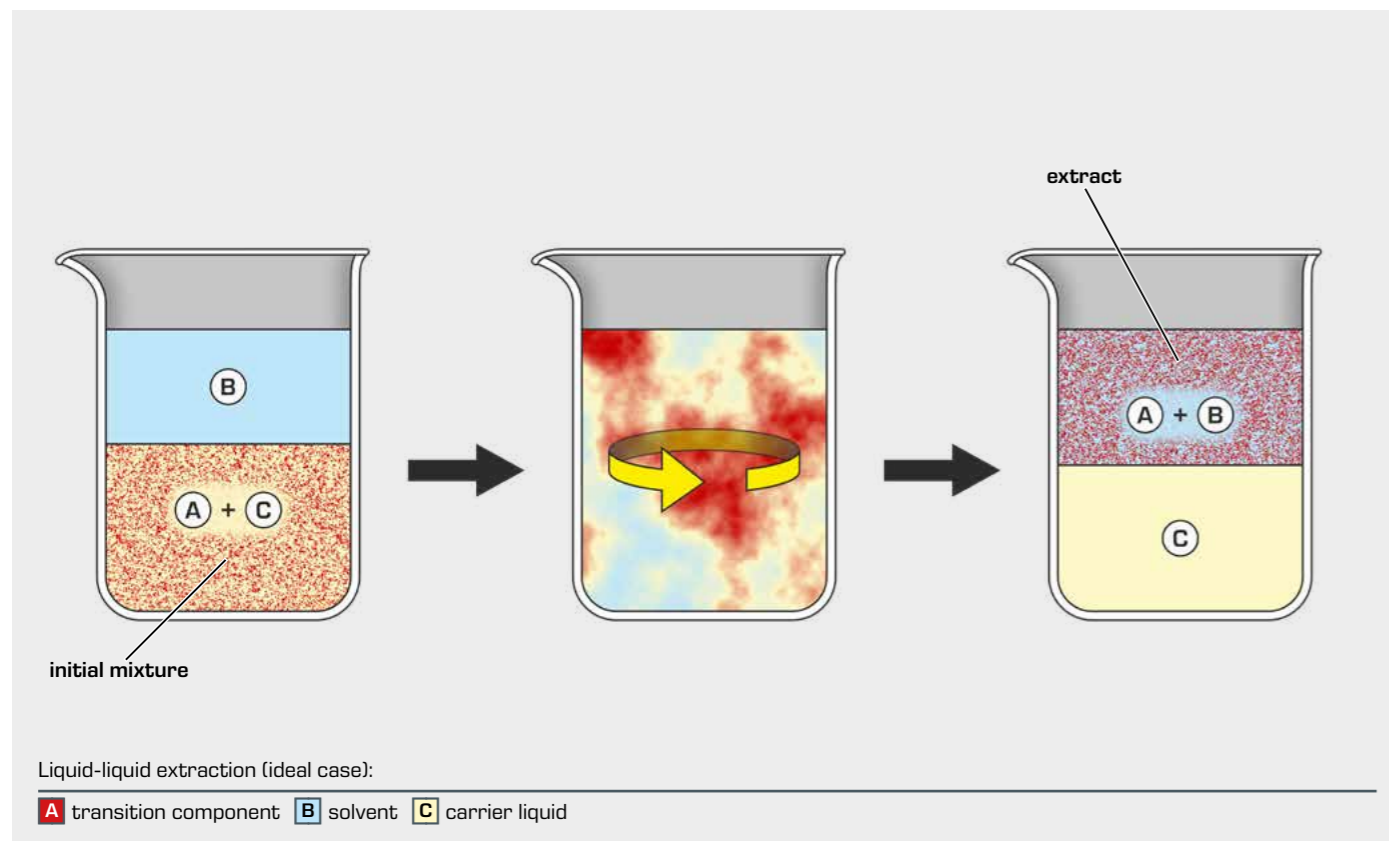

The example illustration assumes an ideal situation in which the transition component A is completely taken up by the solvent. In reality, residual transition component always remains in the carrier liquid. In addition, complete insolubility of the carrier liquid in the solvent is assumed. In practice, parts of one substance will always be found in the other.

This means that the actual separation process results in two phases after settling:

- **Extract phase** (mainly A and B, with residue of C)
- **Raffinate phase** (mainly C, with residue of A and B)

To obtain the purest possible transition component, the extraction is normally followed by a separating stage that takes

the form of rectification, in which the solvent is separated from the transition component. The solvent can be recirculated and is then available for the extraction again.

Basic knowledge

Solid-liquid extraction

Solid-liquid extraction allows soluble components to be removed from solids using a solvent. Applications of this unit operation include obtaining oil from oil seeds or leaching of metal salts from ores.

An everyday example is the preparation of coffee. Here, water (solvent) is used to remove the coffee flavours (transition component) from the coffee powder (extraction material, consisting of solid carrier phase and transition component). Ideally, this results in drinkable coffee (solvent with dissolved flavours), with the completely depleted coffee grounds (solid carrier phase) remaining in the coffee filter.

In reality, the solid carrier phase will still contain some transition component after completion of the extraction. In addition, some of the solvent will still be adsorptively bonded to the solid carrier phase.

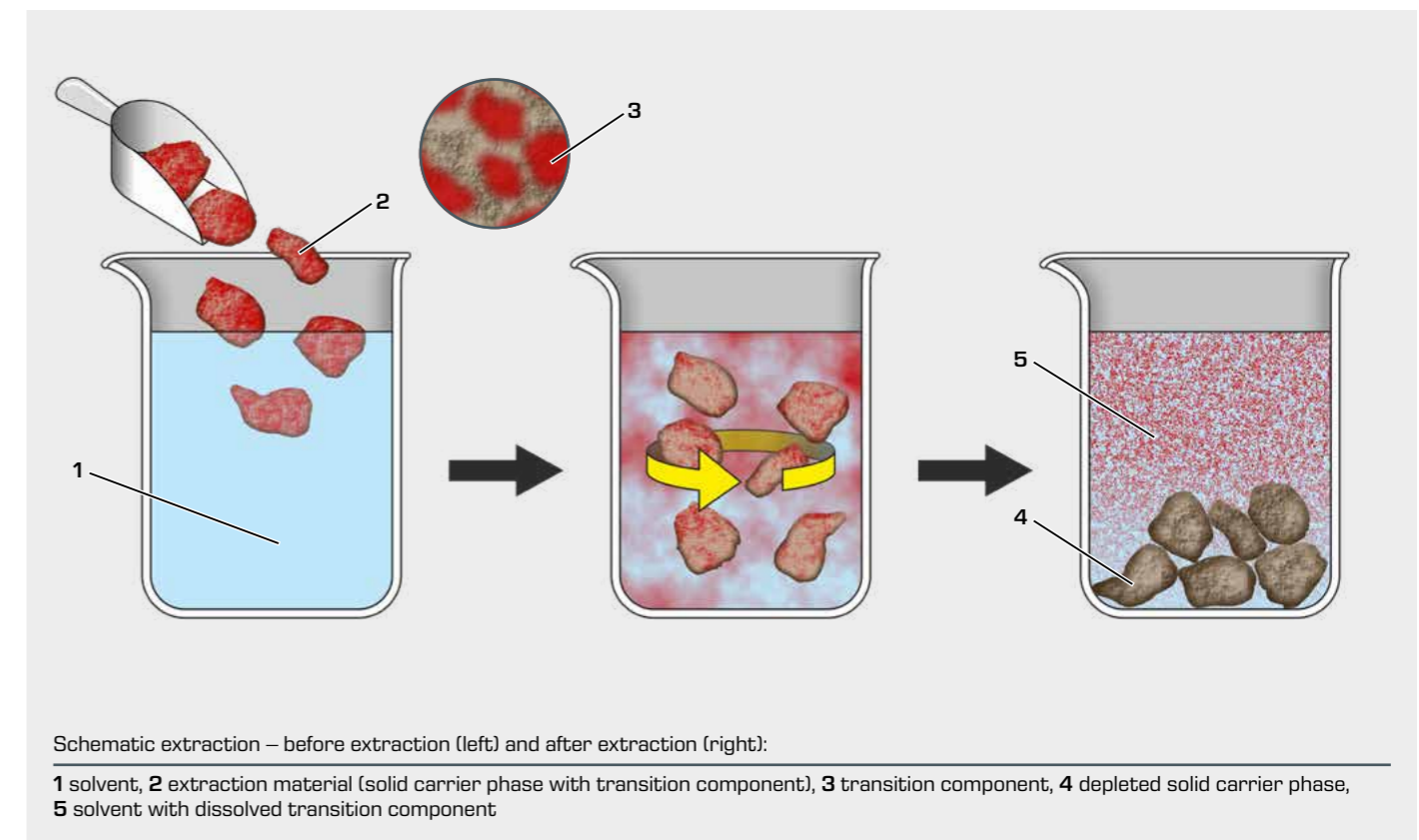

To achieve the fastest and most complete solid extraction possible, the solvent must be provided with large exchange surfaces and short diffusion paths. This can be done by pulverising the solid to be extracted. However, an excessively small grain size can cause agglutination and make it more difficult for the solvent to permeate.

In the simplest form of this unit operation, the extraction material and the solvent are mixed well. The solvent and the dissolved transition component are then removed and regenerated.

The extraction material can also take the form of a fixed bed with the solvent flowing through it. In a further form of the application, the extraction material is led through the solvent.

The solvent is normally regenerated using evaporation/distillation. The solvent is evaporated and a concentrated extract solution is left behind as the product. The solvent is condensed and can then be reused.

CE 620

Liquid-liquid extraction



Learning objectives/experiments

- transition of a component from a two-component liquid mixture into a solvent by extraction
- scale-up from beaker experiment to pilot plant scale
- enrichment of transition component in extract by distillation
- evaluation of separation processes via concentration measurement and mass balances
- influence of different experimental options on separation processes

Description

- separation of a liquid mixture by liquid-liquid extraction in counterflow operation
- enrichment of extract using integrated distillation column
- operation in either continuous or discontinuous process mode is possible
- design and materials allow investigation of different ternary systems
- adjustment and observation of phase boundary possible

The CE 620 allows liquid mixtures to be separated using liquid-liquid extraction.

The liquid mixture to be separated is delivered from the feed tank into the bottom of the extraction column using a pump. There, it moves in counterflow towards the solvent, which is delivered into the top of the extraction column by a pump.

The mixture to be separated is made up of a transition component and carrier liquid. The carrier liquid and the solvent are insoluble in one another and therefore a phase boundary is established in the column. This can be observed and can be adjusted using two valves. The movement of the transition component from the carrier liquid into the solvent occurs inside the column. Two three-way valves can be used to operate the trainer as a continuous or a discontinuous process.

A distillation unit facilitates the enrichment of the transition component in the extract. This consists of a heated round-bottomed flask with a packed column and a distillation bridge with Liebig condenser. The enriched extract leaves the column at the top and is collected in a tank. The bottom temperature is measured by a sensor, displayed digitally and controlled using a PID controller.

The temperature at the top of the distillation column is also measured. Distillation removes the solvent from the transition component which is collected at the bottom of the unit and can be drawn off as a product. The separated solvent is collected in a tank and can be reused for extraction.

For a ternary material system, rapeseed oil is recommended as the carrier liquid with ethanol as the transition component and water as the solvent. For this ternary material system the concentrations of extract, top and bottom product are determined by measurement of density. A conductivity meter is included for alternative ternary material systems.

CE 620

Liquid-liquid extraction

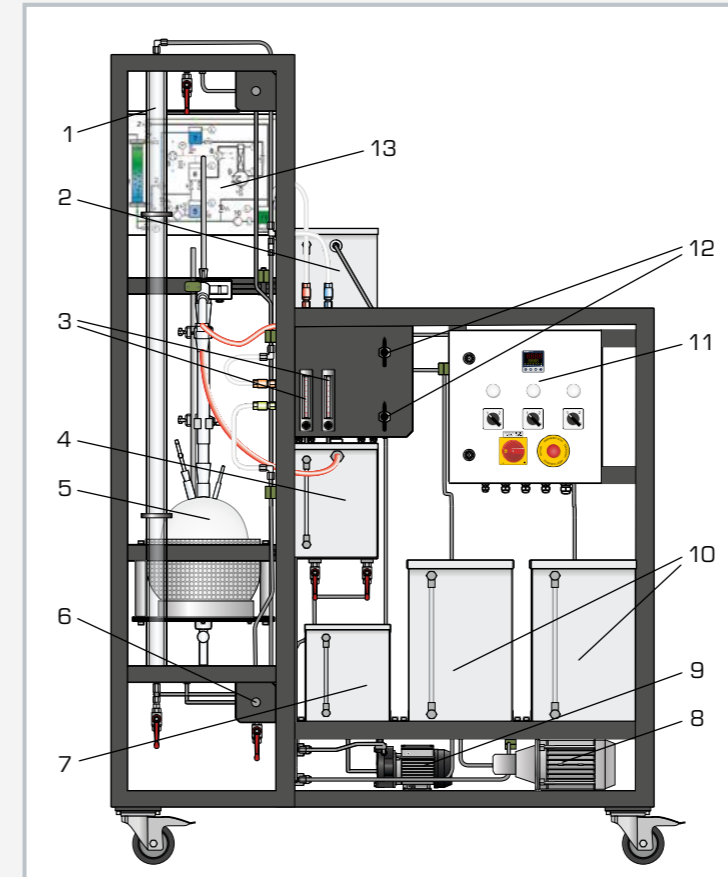

1 extraction column, 2 extract tank, 3 flow meters feed and solvent, 4 top product tank (distillation), 5 distillation unit, 6 valve for phase boundary, 7 solvent tank, 8 feed pump, 9 solvent pump, 10 feed and raffinate tank, 11 switch cabinet, 12 three-way valves, 13 process schematic

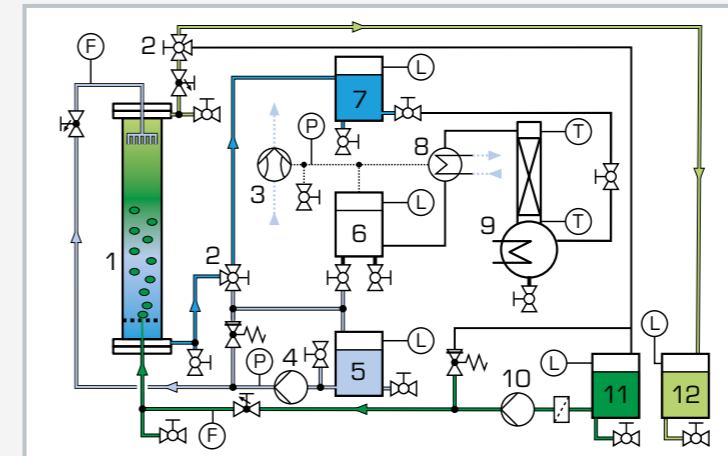

1 extraction column, 2 three-way valves, 3 water jet pump, 4 solvent pump, 5 solvent tank, 6 top product tank (distillation), 7 extract tank, 8 Liebig condenser with cooling water connection, 9 distillation column, 10 feed pump, 11 feed tank, 12 raffinate tank; F flow rate, P pressure, T temperature, L level

Specification

- [1] liquid-liquid extraction in counterflow operation with distillation for enrichment of the extract
- [2] operation as continuous or discontinuous process using 2 three-way valves
- [3] glass extraction column
- [4] distillation column and distillation bridge with Liebig condenser
- [5] electrical bottom heating via PID controller
- [6] water jet pump for reduction of evaporation temperature during distillation
- [7] stainless steel tanks for feed, solvent, raffinate, extract and top product (distillation)
- [8] 2 pumps to deliver the feed and solvent
- [9] 2 valves for adjusting the phase boundary
- [10] distillation column packed with Raschig rings
- [11] accessories housed in a storage system with foam inlay

Technical data

Columns

- extraction: Ø 40mm, height: 1500mm
- distillation: Ø 30mm, height: 415mm

Bottom heater power output: 1200W

Tanks

- feed and raffinate: approx. 30L each
- solvent and extract: approx. 15L each
- top product (distillation): 15L
- bottom tank (distillation): approx. 5L

Feed pump

- max. flow rate: 1000mL/min
- max. head: 80m

Solvent pump

- max. flow rate: 1200mL/min
- max. head: 10m

Water jet pump, final vacuum: approx. 200mbar

Measuring ranges

- temperature: 1x 0...150°C, 1x 0...120°C
- flow rate: 2x 100...850mL/min (water)
- pressure: -1...0,6bar
- conductivity: 0...1990µS/cm

230V, 50Hz, 1 phase

230V, 60Hz, 1 phase; 120V, 60Hz, 1 phase

UL/CSA optional

LxWxH: 1350x750x2150mm

Weight: approx. 180kg

Required for operation

water connection: 720L/h

Scope of delivery

- 1 trainer
- 1 conductivity meter
- 1 set of accessories
- 1 set of instructional material

CE 630

Solid-liquid extraction



Learning objectives/experiments

- fundamentals of solid-liquid extraction
- demonstration of solid-liquid extraction as a continuous and discontinuous process
- investigation of 1-, 2- and 3-stage processes
- influence of solvent flow rate and temperature on the extraction process
- influence of extraction material feed rate and extractor revolving speed on the extraction process

Description

- **discontinuous and continuous solid-liquid extraction**
- **1-, 2- or 3-stage modes possible**
- **regenerable extraction material**
- **GUNT software with control functions and data acquisition**

The CE 630 allows a soluble component of a solid mixture to be extracted with a revolving extractor.

In continuous 3-stage mode, pure solvent (distilled water) is delivered from a tank to the sprinkler of the first extraction stage where it is distributed over the solid mixture (extraction material). The solvent seeps through the extraction material, absorbs its soluble components (potassium hydrogen carbonate) and passes into the collecting segments.

From there, the enriched solvent is delivered to the sprinkler of the next stage. After passing through the last stage, the extract (the solvent charged with the extracted component) is collected in the extract tank. The extraction material is continuously fed into the cells of the rotating extractor by a spiral conveyor. The extraction material and the solvent move in counterflow. The extraction residue drops into a tank after one revolution of the extractor.

Valves can be used to switch to 1- or 2-stage continuous mode. Discontinuous mode is possible with the extractor stopped.

Three pumps are available for delivering the solvent. Their speed can be individually adjusted for each stage. The temperature of the solvent can likewise be adjusted for each stage with PID controllers. Each stage is equipped with conductivity sensors to monitor the separation process. All measured values can be viewed by software.

The solid mixture (extraction material) is produced prior to the extraction experiment. The carrier material (granular aluminium oxide) is fed into a salt solution (potassium hydrogen carbonate dissolved in water). The carrier material soaked with the salt solution is then dried.

CE 630

Solid-liquid extraction



1 process schematic, 2 spiral conveyor for extraction material, 3 revolving extractor, 4 revolving extractor drive unit, 5 pump (behind the tanks), 6 tank, 7 mode selector valves, 8 heater and solvent feed, 9 switch cabinet with controls

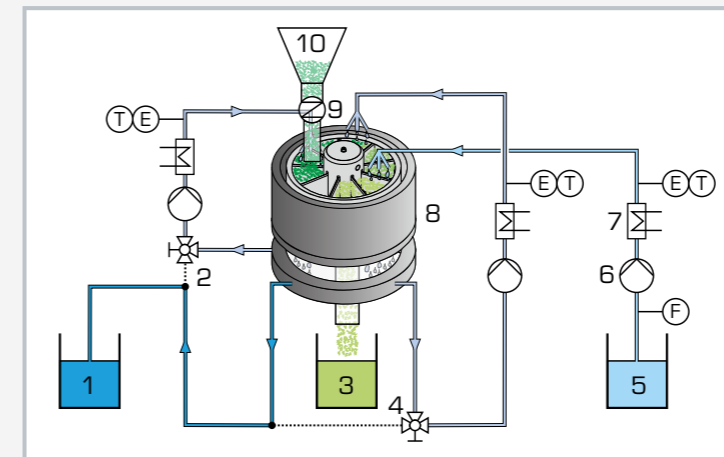

1 extract, 2 connection for 2-stage mode, 3 extraction residue, 4 connection for single-stage mode, 5 solvent, 6 pump, 7 heater, 8 revolving extractor, 9 spiral conveyor, 10 extraction material; T temperature, E conductivity, F flow rate

Specification

- [1] revolving extractor for continuous and discontinuous solid-liquid extraction
- [2] switching to 1-, 2- or 3-stage modes possible by valves
- [3] extractor revolving speed adjustable by potentiometer
- [4] spiral conveyor with variable speed to adjust the extraction material feed rate
- [5] flow rate of solvent adjustable for each stage via speed of pumps
- [6] temperature of solvent adjustable for each stage by PID controller
- [7] tanks for extraction material, extraction residue, solvent and extract
- [8] GUNT software for data acquisition via USB under Windows 8.1, 10

Technical data

Extractor

- 9 cells
- rotor diameter: approx. 200mm
- speed: approx. 0...9h⁻¹
- motor power consumption: approx. 0,9W

Spiral conveyor

- max. feed rate: approx. 20L/h
 - motor power consumption: approx. 4W
- 4 peristaltic pumps
- max. flow rate: approx. 25L/h at 300min⁻¹ and hose 4,8x1,6mm

3 heaters

- power consumption: approx. 330W

Tanks

- extraction material: approx. 5L
- extraction residue, solvent, extract: each approx. 20L

Measuring ranges

- flow rate: 1x 0,025...0,5L/min
- conductivity: 4x 0...20mS/cm
- temperature: 4x 0...50°C

230V, 50Hz, 1 phase

230V, 60Hz, 1 phase; 120V, 60Hz, 1 phase

UL/CSA optional

LxWxH: 1360x780x1900mm

Weight: approx. 150kg

Required for operation

PC with Windows recommended

Scope of delivery

- 1 trainer
- 1 set of tools
- 1 packing unit of aluminium oxide
- 1 packing unit of potassium hydrogen carbonate
- 1 GUNT software + USB cable
- 1 set of instructional material

Basic knowledge

Mass transfer

Mass transfer is one of various basic processes. These are, for example, drying processes, absorptions and adsorptions.

Substance systems or mixtures strive for the lowest possible energetic state. This is also referred to as the driving gradient. For a saline solution, for example, this means that the dissolved salt ions are distributed evenly. After some time, the same concentration will be measurable at every place.

Mass transfer can be studied from the perspective of several mass transfer processes, such as diffusion or convective mass transfer, and is referred to as **overall mass transfer**.

Mass transfer is described with the individual mass transfer processes in a similar way to heat transfer processes. The two diagrams show the profiles of temperature and mole fraction and the respective transfer processes for plane phases.

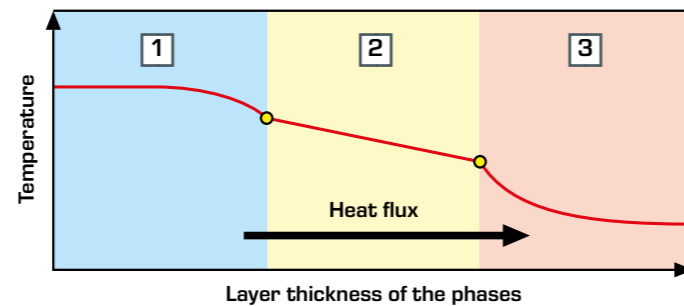

Ideal heat transfer with three plane phases:

1, 3 heat transfer, 2 heat conduction

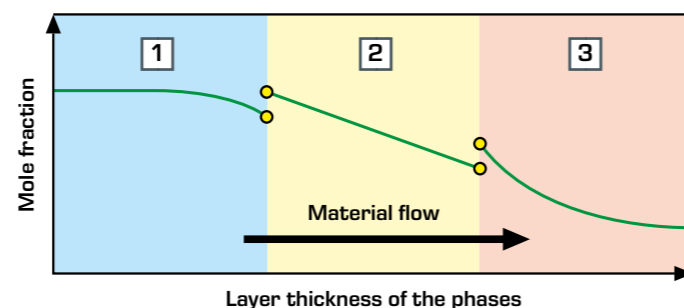

Mass transfer with three plane phases:

1, 3 mass transfer, 2 diffusion

Overall mass transfer

A task with mass transfer usually involves several mass transfer sections to be studied. The transfer process through all sections is referred to as **overall mass transfer**. The individual mass transfer processes are diffusion and mass transfer. These can also occur several times within one task.

Example with dual mass transfer

A gas phase is located above a liquid phase. Both phases are flowing. A substance is present in the gas phase that is soluble in the liquid phase. If the lowest energy state has not yet been reached, the system attempts to reach it. In this case, there is mass transfer of the substance from the gas phase into the liquid phase. In the gas phase mass transfer takes place towards the phase boundary and in the liquid phase mass transfer takes place away from the phase boundary. The mole fractions adjust until equilibrium is reached. The mass flow is calculated using the mass transfer coefficients and the driving gradient, which is formed from the difference of the mole fractions at the phase boundary and the average value within the phase.

One special characteristic of mass transfer is that the solubility of a substance is different in other substances. This means that the concentrations at the phase boundaries are different.

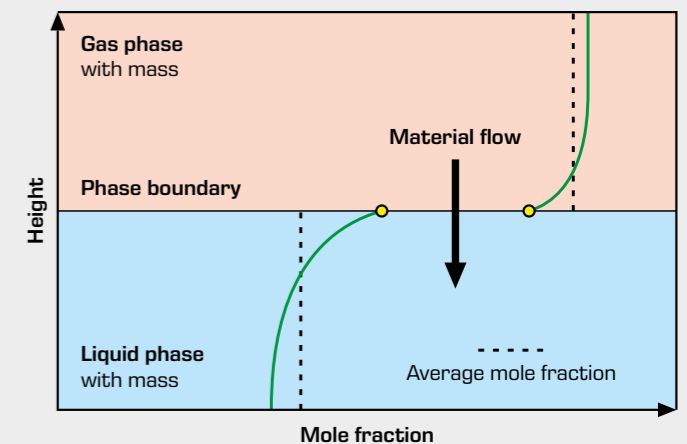

Diffusion

Diffusion is a physical process in which atoms or molecules migrate within a gas, a solution or even a solid. Diffusion is a **mass transfer process** based on molecular motion and is a way of reaching the lowest energy state. In general, diffusion requires a local difference in particle number density, which acts as the driving gradient. Diffusion processes end when an equilibrium of all particle number densities is reached. In solutions this usually takes several hours, whereas in gases it often takes only a few seconds.

The calculation is based on diffusion coefficients, which must be determined for the substances involved. The diffusion coefficient describes the mobility of a substance within another substance or mixture of substances. In the case of a saline solution, for example, it is the mobility of the salt ions within the water.

Diffusion can also be affected by temperature and pressure. The dependence on temperature is usually part of the calculation equation. Pressure is mentioned as additional information to check the validity of the calculation equation for the specific application.

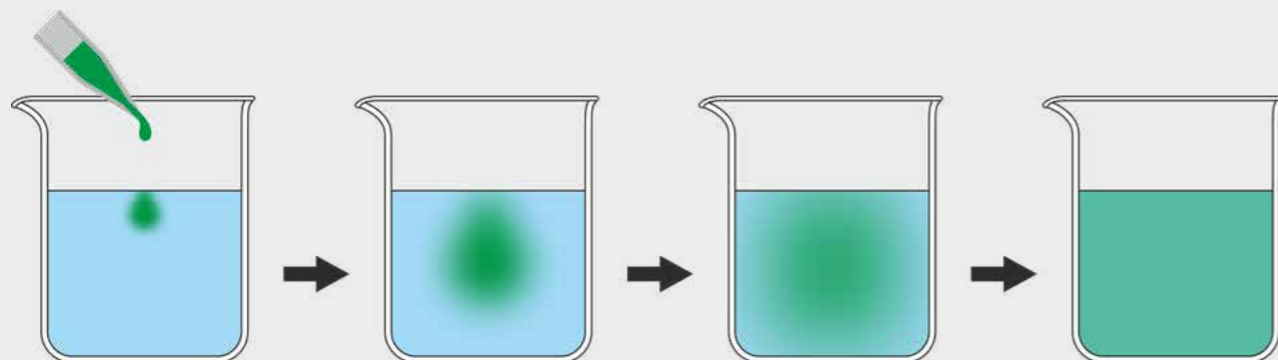

Convective mass transfer

Convective mass transfer is a mass transfer process that takes place when a flow occurs simultaneously. The flow leads to a significantly better mass transfer, so that further equations have been determined for the design. The decisive factors for mass transfer are:

- flow condition (laminar or turbulent)
- degree of flow formation
- degree of profile formation of the mole fractions

Depending on the conditions, the Sherwood number together with the valid **Sherwood function** is used to calculate the mass transfer coefficient.

Example

A liquid phase containing a substance flows along a membrane. The substance is absorbed by the membrane. In the start-up of the profile formation, the mole fraction is constant and then decreases. Since the substance is absorbed by the membrane, the mole fraction sinks more directly at the membrane than further in the flow. The resulting profile of the mole fraction, transverse to the direction of flow, represents a further mass transfer resistance. This is taken into account by the mass transfer coefficient to be calculated in the overall consideration, the overall mass transfer.

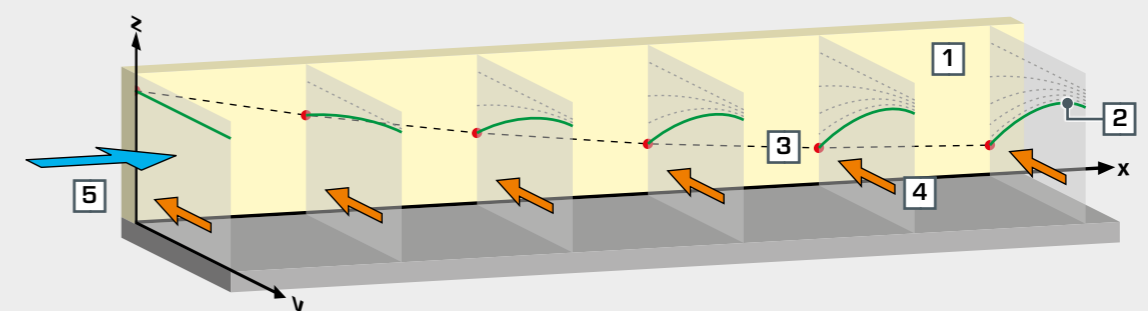

x distance in direction of flow, y distance from the membrane, z mole fraction

1 membrane, 2 mole fraction as a function of distance from the membrane (y), 3 mole fraction in the immediate vicinity of the membrane (y = 0), 4 mass flow towards the membrane, 5 flow

CE 110

Diffusion in liquids and gases



Description

- diffusive mass transport of substances in gases and aqueous solutions
- application of Fick's law

Diffusion is the microscopic mass transport of particles such as atoms, molecules and ions due to differences in concentrations. It plays an important role in numerous processes. For example, diffusion can bring together the reactants in chemical reactions and, in some cases, it can be the rate-limiting step for the process.

CE 110 is equipped with two experimental units for investigating diffusion in liquids and gases. To investigate diffusion in liquids, a concentrated salt solution is used. The solution is contained in a U-tube, one end of which has a disc with several vertical capillaries. The U-tube is immersed into a tank containing demineralised water so that the disc with the capillaries is positioned below the surface of the water. The concentration gradient between water and the solution causes the salt ions to move out of the U-tube through the capillaries into the demineralised water.

The capillaries ensure that the ions move in one dimension. A stirrer in the tank prevents the salt concentration increasing near to the disc, thus preventing concentration differences in the tank. A conductivity meter measures the salt concentration in the tank.

To investigate diffusion in gases, a highly volatile solvent is used. The solvent is contained in a vertical tube which is immersed into a heated water bath. The thermal energy from the water bath causes the solvent to evaporate. A fan generates an air flow, which moves horizontally at the upper end of the tube. The gaseous solvent diffuses due to the concentration gradient from the surface of the liquid solvent upwards to the pure air flow. The air flow transports the solvent molecules away, thus ensuring a constant concentration at the upper end of the tube. The volume of liquid solvent in the tube decreases over time. A scale microscope enables the level to be determined. A heater with controller keeps the temperature in the water bath constant.

Learning objectives/experiments

- fundamentals of diffusion: Fick's law
- derivation of the calculation formula for the diffusion coefficients for the given experimental conditions
- determination of the diffusion coefficient for the mass transport in gas
- determination of the diffusion coefficient for the mass transport in liquid

CE 110

Diffusion in liquids and gases

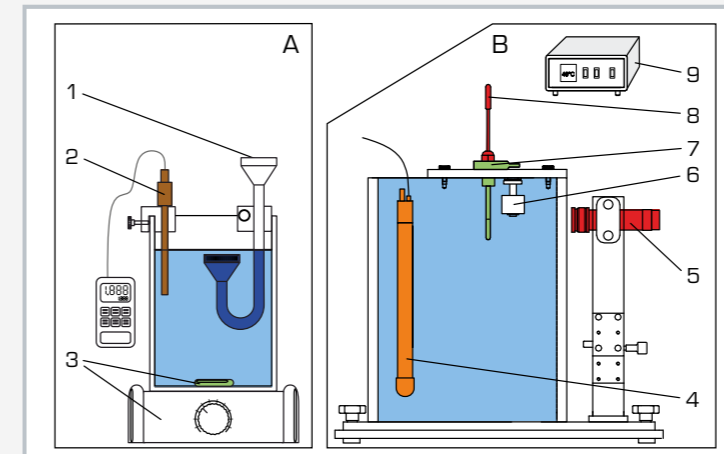

Units for diffusion in liquids (A) and in gases (B): 1 U-tube with capillaries, 2 conductivity sensor, 3 magnetic stirrer with magnetic stir bar, 4 heater in the water bath, 5 microscope, 6 float switch, 7 diffusion tube, 8 temperature sensor, 9 display and control unit

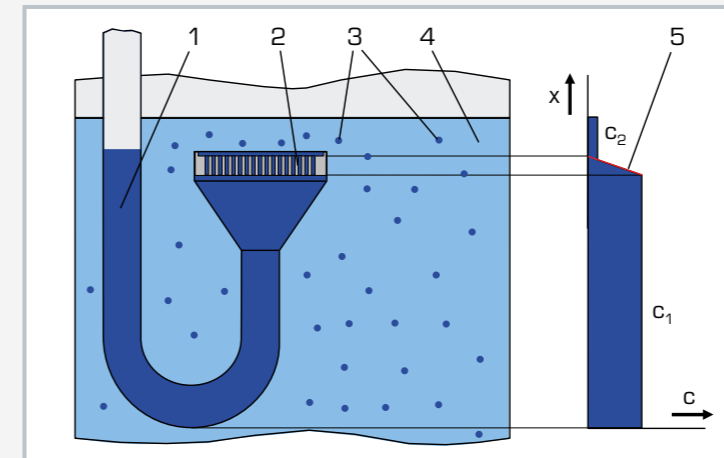

Diffusion in liquids: 1 concentrated salt solution, 2 capillaries, 3 salt ions, 4 water, 5 concentration gradient; x path, c concentration, c_1 concentrated solution, c_2 diluted solution

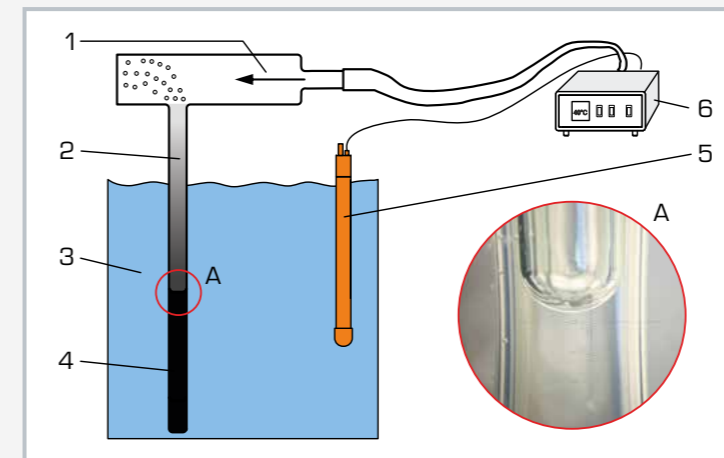

Diffusion in gases: 1 air flow, 2 gaseous solvent, 3 water bath, 4 liquid solvent, 5 heater, 6 display and control unit; A meniscus in the microscope

Specification

- [1] investigation of diffusion in liquids and gases
- [2] transparent tank with magnetic stirrer, conductivity meter and U-tube with capillaries for investigating diffusion in aqueous solutions
- [3] evaporation of a highly volatile solvent with a diffusion tube in a heated water bath for investigating diffusion in gases
- [4] removal of gaseous solvent at the upper end of the diffusion tube with a fan
- [5] heater with controller and sensor for adjusting the temperature in the water bath
- [6] height-adjustable microscope for monitoring and determining the solvent volume in the diffusion tube
- [7] separate display and control unit contains temperature display and fan

Technical data

Tank with stirrer: approx. 1500mL
Speed stirrer: 0...1500min⁻¹
253 capillaries made of stainless steel
■ diameter: 1mm, length: 5mm

Water bath: approx. 2L
Diffusion tube for solvent
■ diameter: 3,4mm, length: 85mm

Power output heater: approx. 125W
Fan: 120...320L/h
Microscope scale division: 0,1mm

Measuring ranges
■ temperature: 0...100°C
■ conductivity: 0...200mS/cm

230V, 50Hz, 1 phase
230V, 60Hz, 1 phase
120V, 60Hz, 1 phase
UL/CSA optional
LxWxH: 210x210x280mm
(experimental unit for diffusion in liquids)
LxWxH: 220x290x450mm
(experimental unit for diffusion in gases)
LxWxH: 370x340x200mm
(conductivity meter)
Weight: approx. 16kg

Scope of delivery

- 1 experimental unit for diffusion in liquids
- 1 experimental unit for diffusion in gases
- 1 display and control unit
- 1 conductivity meter
- 1 magnetic stirrer with 2 magnetic stir bars
- 1 stopwatch
- 1 set of instructional material

Introduction

Overview The GUNT learning concepts of chemical process engineering

136

Thermal activation

Overview CE 310 The modular system for chemical process engineering

138

CE 310
Supply unit for chemical reactors

140

CE 310.01
Continuous stirred tank reactor

142

CE 310.02
Tubular reactor

144

CE 310.03
Stirred tanks in series

146

CE 310.04
Discontinuous stirred tank reactor

148

CE 310.05
Plug-flow reactor

150

CE 310.06
Laminar flow reactor

152

CE 100
Tubular reactor

154

Catalytic activation

Basic knowledge
Catalytic activation

157

Overview
CE 380 Fixed bed catalysis

158

CE 380
Fixed bed catalysis

160

CE 380.01
Flow injection analysis

162

CE 650
Biodiesel plant

164

Photochemical activation

Basic knowledge
Photochemical activation

166

Overview
CE 584 Advanced oxidation

167

CE 584
Advanced oxidation

168

Activation methods and reactor types in chemical process engineering

This chapter presents suitable experimental units to study important activation methods in chemical process engineering. The programme also offers a variety of options to learn about the operating principle, application areas and differences of common reactor types. When selecting the reactions, we made sure that the products can be easily verified and that the chemicals used are as non-hazardous as possible. Nevertheless, handling chemicals requires experience, care and a suitable laboratory environment. Depending on the process and the substances used, sealed floors, drainage systems, water supply, ventilation, secure storage facilities for the substances used, safety devices and protective clothing are required.

For the analysis of many experiments you will need professional analysis systems. These are not included in the scope of delivery of the GUNT training systems.

Please contact us. We will be happy to give advise.

The GUNT learning concepts of chemical process engineering

What does chemical process engineering deal with?

Unlike in mechanical or thermal process engineering, the focus of chemical process engineering is not to change substance properties or the composition of a substance. The central subject of chemical process engineering is the creation of a new substance type through chemical reaction.

The knowledge which reacting agents are required for a desired product comes from chemistry. Chemistry also provides the knowledge of the conditions that enable a smooth chemical reaction process.

These conditions include the activation of the reaction, pressure and temperature adjustment and the composition of the reacting agents. The aim of chemical process engineering is to create these conditions for industrial-scale use. In addition to these conditions, the aggregate state of the reacting agents and reaction products also has a significant influence on the design of the reactors and the overall production process.

How can the chemical processes be classified?

There are several ways of classifying chemical processes. One of them is based on activation energy. Many thermodynamically possible chemical reactions do not take place at all or are too slow for technical applications unless a certain activation energy is applied.

Chemical reactions can be activated in different ways. The activation method significantly influences the design and operation of chemical reactors. It is also possible to combine different activation methods:

- **Thermal activation**
The energy required to activate the chemical reaction can be applied through heat. The desired temperature range is achieved by heating or cooling. In this temperature range, the reaction conditions are optimal and undesired side reactions are avoided.
- **Catalytic activation**
Many reactions are too slow for technical applications at ambient temperature because the required activation energy is very high. Catalysts lower the required activation energy and accelerate the chemical reaction. There are two types of catalysis:
 - ▶ **Homogeneous catalysis**
The catalyst and the starting substances of the chemical reaction are in the same phase.
 - ▶ **Heterogeneous catalysis**
The catalyst is in the solid phase in most cases. The starting substances of the reaction are in the liquid or gaseous phase.
- **Photochemical activation**
The reaction is activated by atoms or molecules absorbing optical radiation. The mostly organic substances thus achieve a higher energy level and are activated.



Supply unit for chemical reactors CE 310
with continuous stirred tank reactor CE 310.01

Our training systems for chemical process engineering

Thermal activation	CE 310.01 Continuous stirred tank reactor CE 310.02 Tubular reactor CE 310.03 Stirred tanks in series CE 310.04 Discontinuous stirred tank reactor CE 310.05 Plug-flow reactor CE 310.06 Laminar flow reactor CE 100 Tubular reactor
Catalytic activation	CE 380 Fixed bed catalysis CE 650 Biodiesel plant
Photochemical activation	CE 584 Advanced oxidation

Abstract processes clearly illustrated

The diagram shows the photochemical activation process where UV light (represented by wavy arrows) is absorbed by a hydrogen peroxide molecule (H-O-O-H), leading to the formation of hydroxyl radicals (·OH). Below this, two laboratory setups are shown: CE 380 Fixed bed catalysis, which includes a reactor unit with a control panel and a small blue power supply; and CE 584 Advanced oxidation, which features a tall, vertical cylindrical reactor with a blue liquid inside and a spray nozzle at the top.

CE 380 Fixed bed catalysis

CE 584 Advanced oxidation

Overview CE 310 The modular system for chemical process engineering

One supply unit for all reactor types



The supply unit is equipped with all components that are required for operating the different reactors:

- tanks and pumps to supply the reactants, intermediate products and products.
- measuring equipment to determine the product concentrations
- water circuit for heating of the reactors and cooling with WL 110.20 Water chiller
- controls to adjust the flow rates and temperature

Learning contents:
in conjunction with a reactor (CE 310.01 – CE 310.06):

- conversion determination of substances depending on
 - ▶ reactor type
 - ▶ retention time in the reactor
 - ▶ temperature
 - ▶ concentration
- fundamentals of a saponification reaction
- determination of retention time distribution
- design and operating principles of different reactor types

Software for data acquisition

Main features

- process schematic with display of the current measured data for each reactor type
- development of the conductivities over time as the measure for product concentration
- development of the temperature in the reactors over time
- conversion determination for a 2nd order reaction

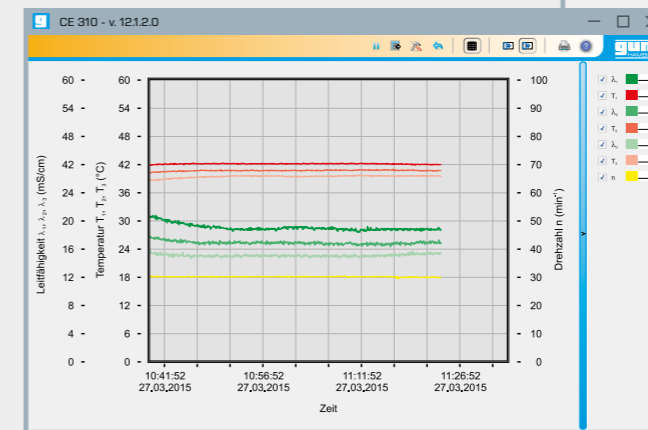
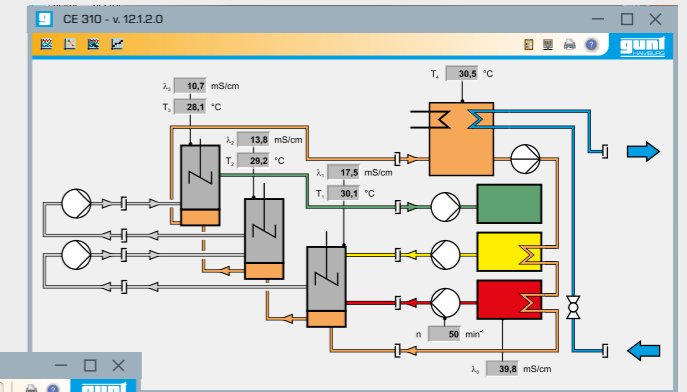

The data acquisition software supports the entire range of experiments with the six different reactors.

About the product:

Stirred tank reactor



CE 310.04
Discontinuous stirred tank reactor

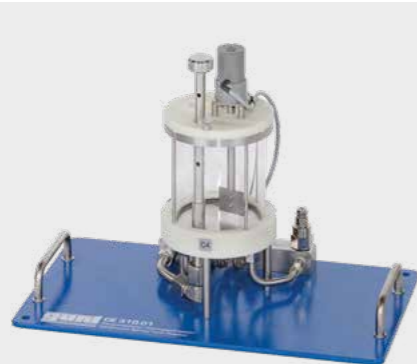
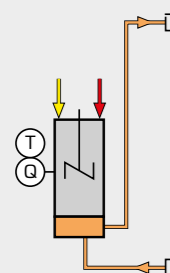

CE 310.01
Continuous stirred tank reactor

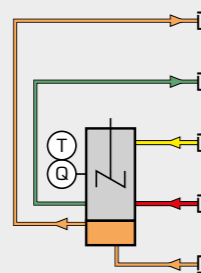

CE 310.03
Stirred tanks in series

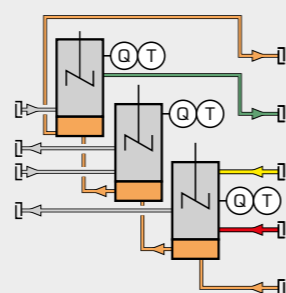

Tubular reactors



CE 310.02
Tubular reactor

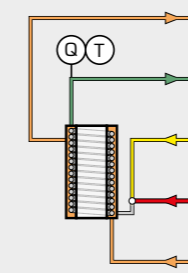

CE 310.05
Plug-flow reactor

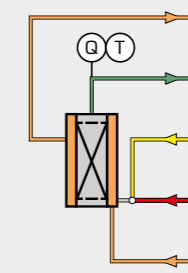

CE 310.06
Laminar-flow reactor

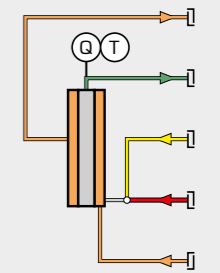

CE 310

Supply unit for chemical reactors



Description

- supply unit for various reactors (CE 310.01 – CE 310.06)
- saponification reaction with conductivity measurement to determine the conversion
- preheating of the reactants

The reactor is the core element of a chemical production facility. In the reactor, the starting substances (reactants) react with each other to form a new substance (product). The reactor has to guarantee the conditions for an optimal reaction process. This primarily concerns the temperature in the reactor. Different types of reactors are used, depending on the requirements.

CE 310 serves as a supply unit for six different reactors. The reactor to be examined is mounted onto the supply unit and held by two pins in position.

For continuous operation of the reactors, two tanks for the reactants are arranged on the trainer. The supply unit and the reactor are hydraulically connected via hoses. The hoses are equipped with quick-release couplings for easy attachment. Two pumps convey the two reactants into the reactor. The retention time of the reactants in the reactor can be adjusted via the pump speed. In the reactor, the reactants react to form a product.

An additional tank and an additional pump for the product is provided.

The supply unit is equipped with a heating water circuit with pump, tank and heater to control the temperature in the reactor. The cold water circuit can be fed from the WL 110.20 water chiller.

Conductivity and temperature in the reactor are measured with a combined sensor. The switch cabinet contains the necessary controls to start the stirrers in the different reactors.

The measured values are digitally displayed on the switch cabinet. At the same time, they can also be transmitted directly to a PC via USB where they can be analysed with the data acquisition software included in the scope of delivery.

Learning objectives/experiments

- in conjunction with a reactor (CE 310.01 – CE 310.06):
 - ▶ learning the design and operation of different reactor types
 - ▶ conversion depending on reactor type
 - ▶ conversion depending on retention time in the reactor
 - ▶ conversion depending on temperature
 - ▶ conversion depending on concentration
 - ▶ fundamentals of a saponification reaction
 - ▶ determination of the retention time distribution

CE 310

Supply unit for chemical reactors

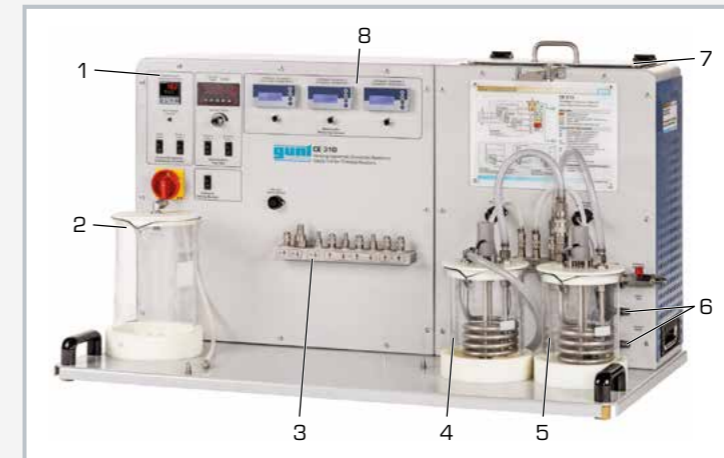

1 displays and controls, 2 product tank, 3 connection block, 4 and 5 tanks for reactants, 6 water connection, 7 water tank, 8 display of conductivity and temperature

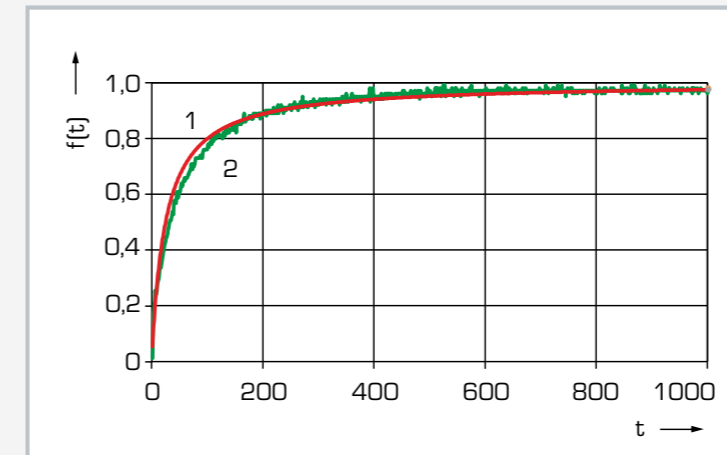

Course of conversion over time with discontinuous stirred tank reactor (CE 310.04)
1 theoretical conversion, 2 measured conversion; $f(t)$ conversion, t time

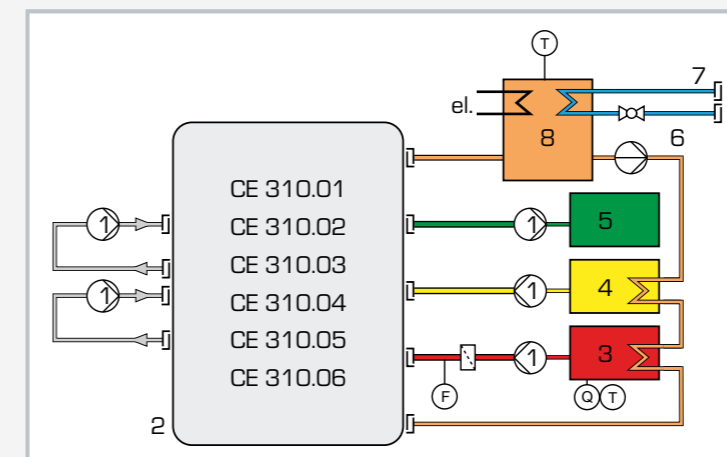

process schematic with supply unit CE 310
1 peristaltic pump, 2 reactor, 3 reactant A tank, 4 reactant B tank, 5 product tank, 6 water pump, 7 water connection, 8 water tank; G conductivity, F flow rate, T temperature

Specification

- [1] supply unit for 6 different chemical reactor types
- [2] connection of the reactors via hoses with quick-release couplings
- [3] water circuit with tank, heater, temperature controller, pump and low water cut-off for heating and cooling (with WL 110.20 water chiller)
- [4] temperature control of the reactants and reactors
- [5] 3 glass tanks for reactants and products
- [6] 5 peristaltic pumps to deliver the reactants and products
- [7] 2 combined sensors for measuring the conductivity and temperature
- [8] GUNT software for data acquisition via USB under Windows 8.1, 10

Technical data

Peristaltic pump for reactants

- max. flow rate: approx. 180mL/min
- with hose 8,0x4,8mm

Peristaltic pump for products

- max. flow rate: approx. 420mL/min
- with hose 8,0x4,8mm

Water pump

- max. flow rate: 10L/min
- max. head: 30m
- power consumption: 120W

Heater

- power consumption: 1500W

Tanks

- reactants: 2x 3L
- product: 5L
- heating water: 8L

Measuring ranges

- conductivity: 2x 0...100mS/cm
- temperature: 2x 0...55°C, 1x 0...60°C
- flow rate: 1x 0...240L/min

230V, 50Hz, 1 phase
230V, 60Hz, 1 phase; 120V, 60Hz, 1 phase
UL/CSA optional
LxWxH: 1170x670x690mm
Weight: approx. 82kg

Required for operation

water connection, drain / WL 110.20
Ethyl acetate, caustic soda (for saponification reaction)
PC with Windows recommended

Scope of delivery

- 1 experimental unit
- 2 combined sensors (conductivity and temperature)
- 1 GUNT software + USB cable
- 1 set of instructional material

CE 310.01

Continuous stirred tank reactor



Description

- stirred tank reactor for connection to supply unit CE 310
- transparent materials to observe the process
- isothermal operation
- adjustable reactor volume
- determination of the conversion in a saponification reaction

Stirred tank reactors can be operated continuously or discontinuously. Discontinuously operated stirred tank reactors are mostly used if the product quantities to be produced are small or the reactions are slow. Continuous stirred tank reactors enable the reliable production of large product quantities with a consistent quality.

CE 310.01 is part of a device series that enables experiments with different reactor types. In conjunction with the supply unit CE 310, it is possible to examine the function and behaviour of a stirred tank reactor in continuous and discontinuous operation. The supply unit CE 310 has a heating water circuit as well as all necessary connections, pumps, tanks for reactants and a product tank.

CE 310.01 is mounted onto the supply unit and held by two pins in position.

Quick-release couplings enable easy connection of the reactor to the supply unit.

In continuous operation, two pumps on the supply unit deliver the reactants into the reactor. A stirrer ensures a homogeneous mixture and thus increases the direct contact of the reactants. The product is formed by reaction of the reactants through an overflow and is delivered into a tank of the supply unit.

The height of the overflow is variable. The reactor volume is therefore adjustable. The retention time of the reactants in the reactor is adjusted via the speed of the pumps on the supply unit. A chambered bottom in the stirred tank reactor serves as the heat exchanger to examine the influence of the temperature on the reaction.

The conversion in the stirred tank reactor is determined by measuring the conductivity. A combined conductivity/temperature sensor is included in CE 310. Conductivity and temperature are digitally displayed on the switch cabinet of the supply unit. In addition, the measured values can be captured and processed with data acquisition software (included in CE 310).

Learning objectives/experiments

- fundamentals of a saponification reaction
- conversion depending on
 - ▶ retention time
 - ▶ temperature
 - ▶ concentration

CE 310.01

Continuous stirred tank reactor

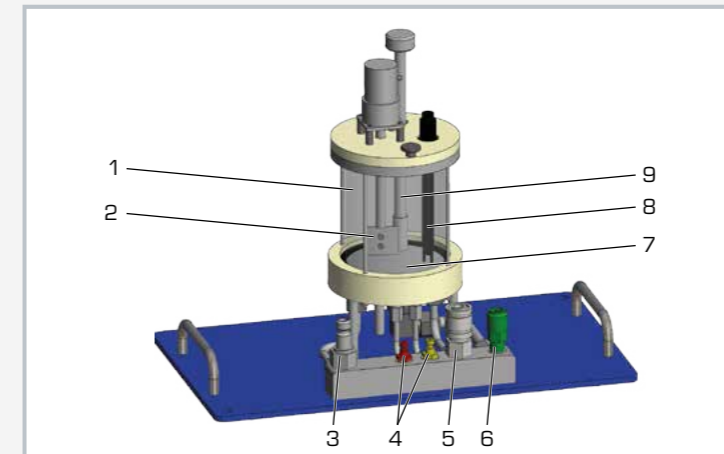

1 stirred tank reactor, 2 stirrer, 3 water supply, 4 reactants A/B supply, 5 water drain, 6 product drain, 7 chambered bottom as heat exchanger, 8 sensor for conductivity and temperature (included in CE 310), 9 height-adjustable overflow

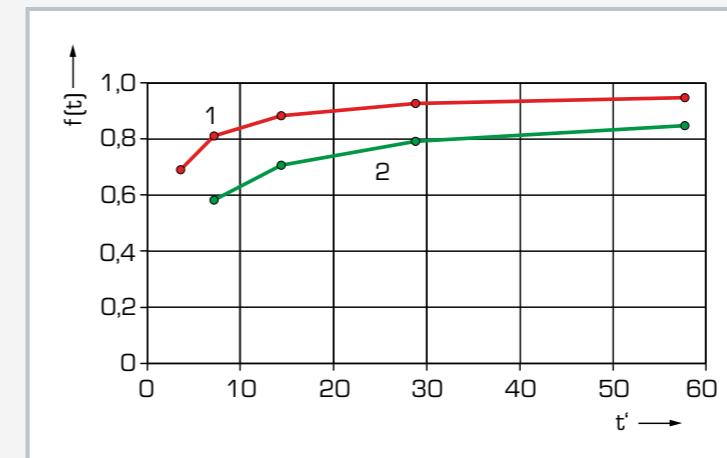

Conversions for different retention times and temperatures
1 high temperature, 2 low temperature; $f(t)$ conversion, t' retention time

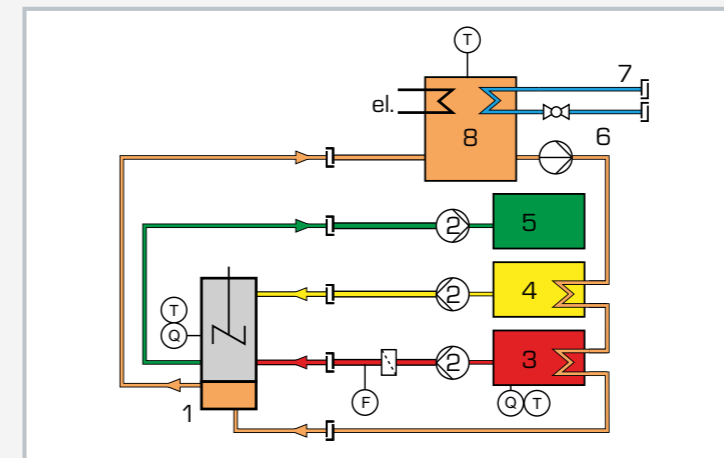

process schematic with supply unit CE 310
1 stirred tank reactor, 2 peristaltic pump, 3 reactant A tank, 4 reactant B tank, 5 product tank, 6 water pump, 7 water connection, 8 water tank; Q conductivity, F flow rate, T temperature

Specification

- [1] continuous stirred tank reactor for connection to supply unit CE 310
- [2] glass tank
- [3] height-adjustable overflow for changing the reactor volume
- [4] reactor with stirrer
- [5] chambered bottom made of stainless steel as heat exchanger for connection to CE 310
- [6] sensor for measuring the conductivity and temperature via CE 310
- [7] temperature control in the reactor via CE 310

Technical data

- Stirred tank reactor
- outer diameter: 110mm
 - inside diameter: 100mm
 - height: 120mm
 - adjustable volume: 270...750mL

- Speed stirrer
- approx. 330min⁻¹

LxWxH: 440x250x320mm
Weight: approx. 10kg

Scope of delivery

- 1 continuous stirred tank reactor

CE 310.02 Tubular reactor



Description

- tubular reactor for connection to supply unit CE 310
- transparent materials to observe the process
- determination of the conversion in a saponification reaction

Tubular reactors are continuously operated reactors. They enable economic production of large product quantities with a consistent quality.

CE 310.02 is part of a device series that enables experiments with different reactor types. In conjunction with the supply unit CE 310, it is possible to examine the function and behaviour of a tubular reactor. The supply unit CE 310 has a heating water circuit as well as all necessary connections, pumps, tanks for reactants and a product tank.

CE 310.02 is mounted onto the supply unit and held by two pins in position. Quick-release couplings enable easy connection of the reactor to the supply unit.

The two pumps of the supply unit deliver the reactants separately through each nozzle into the reactor.

The nozzle outlets are located in a T-piece in such a way that the two reactants are mixed in the centre of the T-piece. The mixture enters into the helical tube in which the two reactants react. The mixture of product and unconverted reactants leaves the tube and is transported into a tank of the supply unit.

The retention time of the reactants in the tubular reactor is adjusted via the speed of the pumps on the supply unit. The tube is also located in the water bath. The water bath is connected to the heating water circuit of the supply unit, which enables the user to examine the influence of the temperature on the reaction.

The conversion in the tubular reactor is determined by measuring the conductivity. A combined conductivity/temperature sensor is included in CE 310. Conductivity and temperature are digitally displayed on the switch cabinet of the supply unit. In addition, the measured values can be captured and processed with data acquisition software (included in CE 310).

Learning objectives/experiments

- fundamentals of a saponification reaction
- conversion depending on
 - ▶ retention time
 - ▶ temperature
 - ▶ concentration

CE 310.02 Tubular reactor

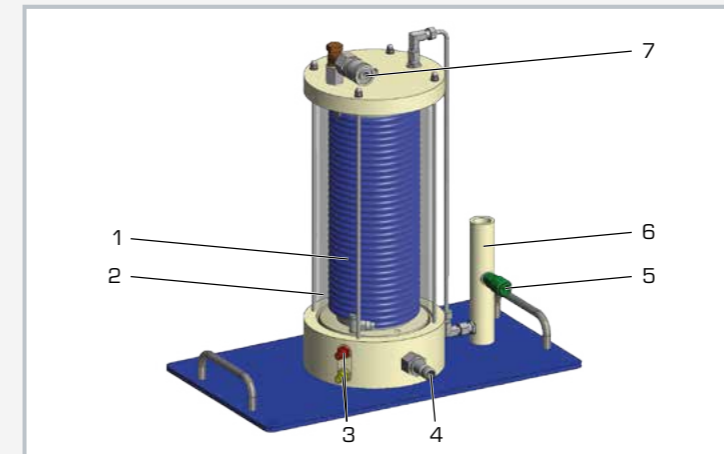

1 tubular reactor, 2 double jacket, 3 reactants A/B supply, 4 water supply, 5 product drain, 6 sleeve for sensor for conductivity and temperature (included in CE 310), 7 water drain

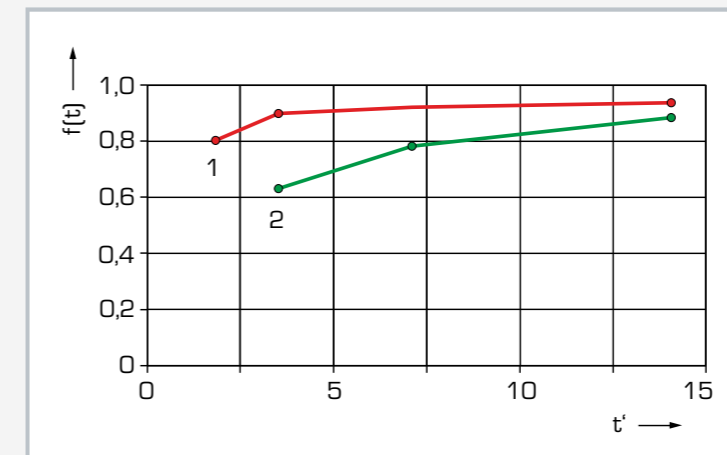

Conversions for different retention times and temperatures
1 high temperature, 2 low temperature; $f(t)$ conversion, t' retention time

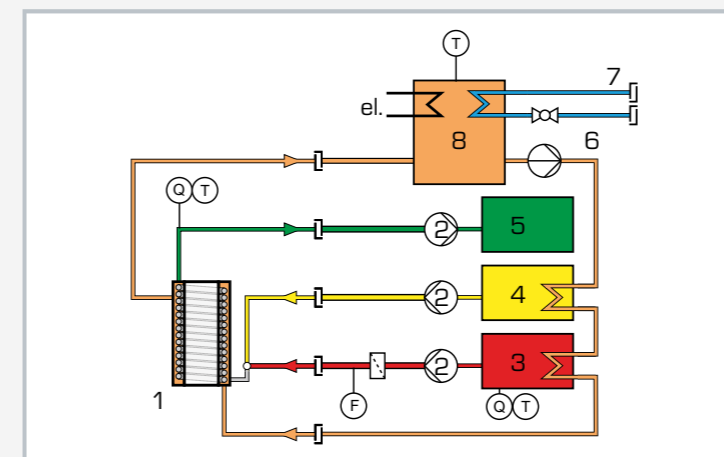

Process schematic with supply unit CE 310
1 tubular reactor, 2 peristaltic pump, 3 reactant A tank, 4 reactant B tank, 5 product tank, 6 water pump, 7 water connection, 8 water tank; Q conductivity, F flow rate, T temperature

Specification

- [1] tubular reactor for connection to supply unit CE 310
- [2] helical plastic tube as reactor
- [3] T-piece with 2 nozzles for mixing the preheated reactants
- [4] transparent PMMA tank as water bath for the reactor and for connection to the heating water circuit of CE 310
- [5] sensor for measuring the conductivity and temperature via CE 310
- [6] temperature control in the reactor via CE 310

Technical data

Tubular reactor

- inside diameter: 6mm
- reactor capacity: approx. 280mL
- material: PA

Water bath

- inside diameter: 132mm
- outer diameter: 140mm
- capacity: 2L
- material: PMMA

LxWxH: 440x250x430mm

Weight: approx. 11,5kg

Scope of delivery

- 1 tubular reactor

CE 310.03

Stirred tanks in series



Description

- stirred tanks in series for connection to supply unit CE 310
- transparent materials to observe the process
- determination of the conversion in a saponification reaction possible for every stage
- isothermal operation

Stirred tanks in series are, as the name says, continuous stirred tank reactors connected in series. They enable a higher conversion than a single stirred tank reactor. Stirred tanks in series enable flexible process control as the temperature and retention time can be set separately for each individual reactor.

CE 310.03 is part of a device series that enables experiments with different reactor types. In conjunction with the supply unit CE 310, it is possible to examine the function and behaviour of stirred tanks in series. The supply unit CE 310 has a heating water circuit as well as all necessary connections, pumps, tanks for reactants and a product tank.

CE 310.03 is mounted onto the supply unit and held by two pins in position. Quick-release couplings enable easy connection of the reactor to the supply unit.

In continuous three-stage operation, two pumps of the supply unit deliver the reactants into the first reactor. A stirrer ensures a homogeneous mixture and thus increases the direct contact of the reactants. The product is formed by reaction of the reactants. The mixture of product and unconverted reactants leaves the reactor through an overflow and is then delivered into two further identical reactors one after the other. The intermediate delivery occurs via 2 further peristaltic pumps of the supply unit. After the third reactor the transport occurs in a tank of the supply unit.

The retention time of the reactants in the reactor is adjusted via the speed of the pumps on the supply unit.

The conversions in the individual reactors is determined by measuring the conductivity. A combined conductivity/temperature sensor is included. Conductivity and temperature are digitally displayed on the switch cabinet of the supply unit. In addition, the measured values can be captured and processed with data acquisition software (included in CE 310).

Learning objectives/experiments

- fundamentals of a saponification reaction
- conversion in each reactor depending on
 - ▶ retention time
 - ▶ temperature
 - ▶ concentration

CE 310.03

Stirred tanks in series

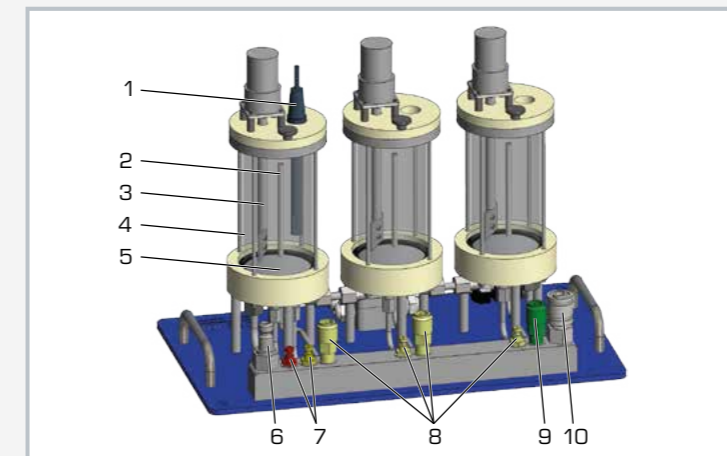

1 sensor for conductivity and temperature, 2 overflow, 3 stirrer, 4 stirred tank, 5 chambered bottom as heat exchanger, 6 water supply, 7 reactants A/B supply, 8 intermediate delivery, 9 product drain, 10 water drain

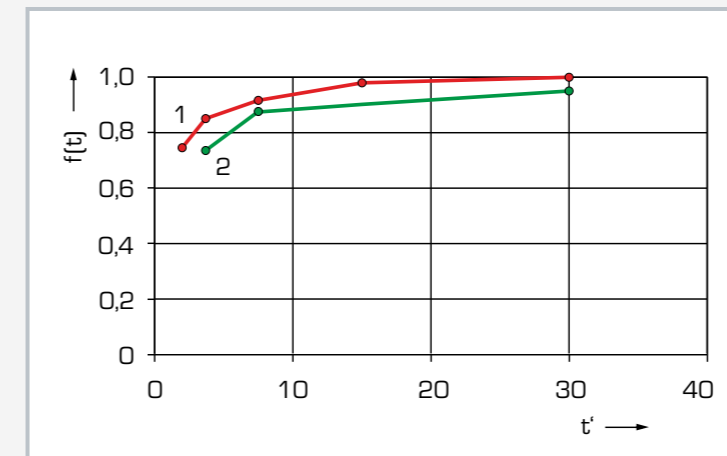

Conversions for different retention times and temperatures
1 high temperature, 2 low temperature; $f(t)$ conversion, t' retention time per reactor

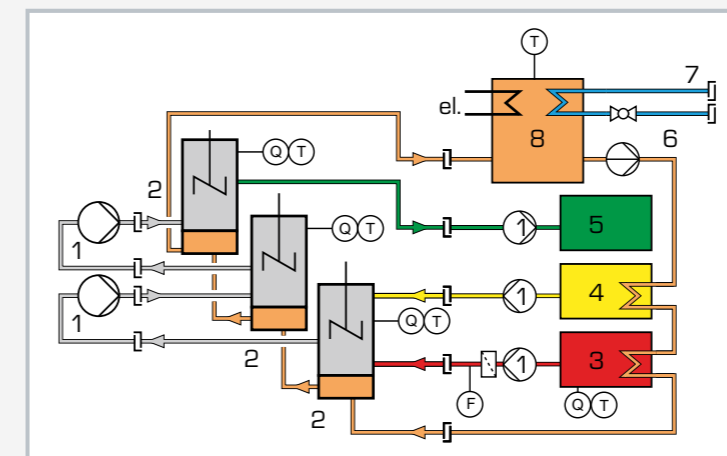

Process schematic with supply unit CE 310
1 peristaltic pump, 2 stirred tank, 3 reactant A tank, 4 reactant B tank, 5 product tank, 6 water pump, 7 water connection, 8 water tank; Q conductivity, F flow rate, T temperature

Specification

- [1] stirred tanks in series for connection to supply unit CE 310
- [2] 3 identical stirred tank reactors made of glass connected in series
- [3] chambered bottom made of stainless steel as heat exchanger for connection to CE 310
- [4] delivery between stirred tanks via 2 peristaltic pumps of the supply unit
- [5] small reactor capacity for less consumption of chemicals
- [6] sensor for measuring the conductivity and temperature
- [7] display of conductivity and temperature via CE 310
- [8] temperature control in the reactor via CE 310

Technical data

- 3 reactors
- outer diameter: each 80mm
 - inside diameter: each 70mm
 - height: each 140mm
 - reactor capacity: each approx. 350mL

- Stirrer speed
- 3x approx. 330min⁻¹

- Measuring ranges
- conductivity: 0...100mS/cm
 - temperature: 0...60°C

- LxWxH: 440x250x350mm
Weight: approx. 14kg

Scope of delivery

- 1 set of reactors
- 1 sensor for conductivity and temperature

CE 310.04

Discontinuous stirred tank reactor



Description

- discontinuous stirred tank reactor for connection to supply unit CE 310
- transparent materials to observe the process
- isothermal operation
- determination of the conversion in a saponification reaction

Discontinuously operated stirred tank reactors are mostly used if the product quantities to be produced are small or the reactions are slow.

CE 310.04 is part of a device series that enables experiments with different reactor types. In conjunction with the supply unit CE 310, it is possible to examine the function and behaviour of a discontinuous stirred tank reactor. The supply unit CE 310 has a heating water circuit as well as all necessary connections, pumps, tanks for reactants and a product tank.

CE 310.04 is mounted onto the supply unit and held by two pins in position. Quick-release couplings enable easy connection of the reactor to the supply unit.

The reactants are preheated in the supply unit at the beginning. After that the reactants are delivered into the stirred tank reactor. A stirrer ensures a homogeneous mixture and thus increases the direct contact of the reactants.

In isothermal operation, a chambered bottom in the stirred tank reactor serves as the heat exchanger to examine the influence of the temperature on the reaction.

The conversion in the stirred tank reactor is determined by measuring the conductivity. A combined conductivity/temperature sensor is included in CE 310. Conductivity and temperature are digitally displayed on the switch cabinet of the supply unit. In addition, the measured values can be captured and processed with data acquisition software (included in CE 310).

Learning objectives/experiments

- fundamentals of a saponification reaction
 - ▶ determination of reaction rate constant
 - ▶ determination of temperature dependence of reaction rate constant
- conversion depending on
 - ▶ reaction time
 - ▶ temperature
 - ▶ concentration

CE 310.04

Discontinuous stirred tank reactor

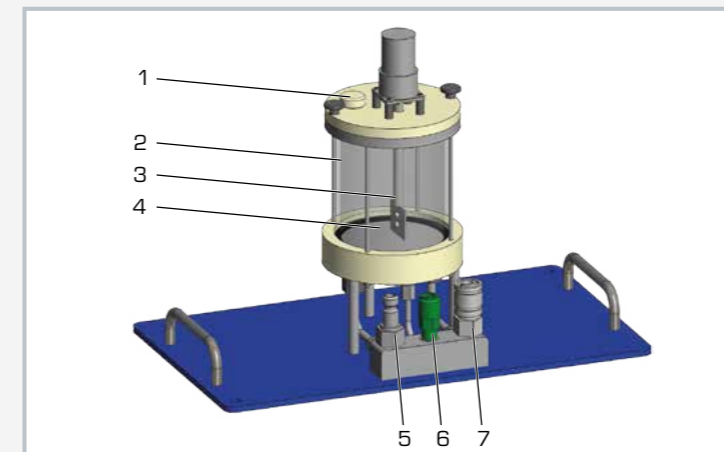

1 hole for sensor for conductivity and temperature (included in CE 310), 2 stirred tank reactor, 3 stirrer, 4 chambered bottom as heat exchanger, 5 water supply, 6 product drain, 7 water drain

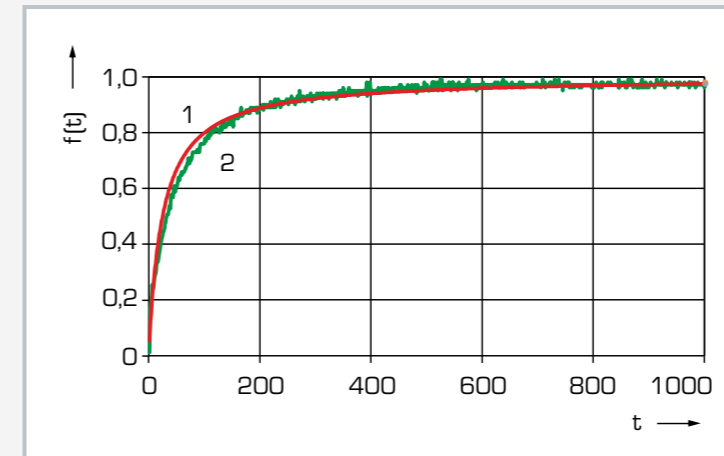

Course of conversion over time
1 theoretical conversion, 2 measured conversion; $f(t)$ conversion, t' time

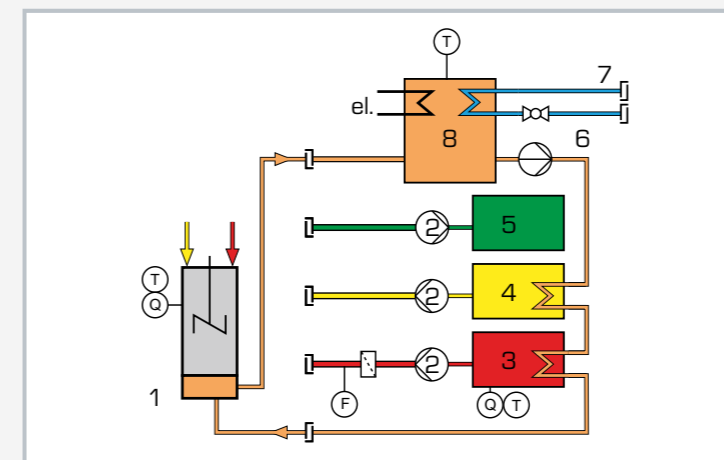

Process schematic with supply unit CE 310
1 stirred tank reactor, 2 peristaltic pump, 3 reactant A tank, 4 reactant B tank, 5 product tank, 6 water pump, 7 water connection, 8 water tank; Q conductivity, F flow rate, T temperature

Specification

- [1] discontinuous stirred tank reactor for connection to supply unit CE 310
- [2] reactor with stirrer
- [3] chambered bottom made of stainless steel as heat exchanger for connection to CE 310
- [4] sensor for measuring the conductivity and temperature via CE 310
- [5] temperature control in the reactor via CE 310

Technical data

Reactor

- outer diameter: 110mm
- inside diameter: 100mm
- height: 140mm
- capacity: approx. 750mL

Speed stirrer: approx. 330min^{-1}

LxWxH: 440x250x320mm

Weight: approx. 10kg

Scope of delivery

- 1 discontinuous stirred tank reactor
- 2 beakers
- 1 funnel

CE 310.05 Plug-flow reactor



Learning objectives/experiments

- fundamentals of a saponification reaction
- continuous operation
- conversion depending on
 - ▶ retention time
 - ▶ temperature
 - ▶ concentration
- retention time distribution



Description

- plug-flow reactor for connection to supply unit CE 310
- continuous operation
- fixed bed with glass spheres
- transparent materials to observe the process
- isothermal operation
- determination of the conversion in a saponification reaction

Plug flow reactors are tubular reactors and are operated continuously. They allow analyses of chemical reactions under defined conditions.

CE 310.05 is part of a device series that enables experiments with different reactor types. In conjunction with the supply unit CE 310, it is possible to examine the function and behaviour of a plug-flow reactor in continuous operation.

The supply unit CE 310 has a heating water circuit as well as all necessary connections, pumps, tanks for reactants and a product tank. In combination with WL 110.20 Water Chiller and the supply unit CE 310 it is also possible to cool the reactors.

CE 310.05 is mounted onto the supply unit and held by two pins in position. Quick-release couplings enable easy connection of the reactor to the supply unit.

In continuous operation, two pumps on the supply unit deliver the reactants into the reactor. The fixed bed with glass spheres results in a flow over the entire cross-section of the reactor. The product is formed by reaction of the reactants. The mixture of product and unconverted reactants leaves the reactor through the upper end. The mixture is transported into a tank of the supply unit via an additional peristaltic pump.

The retention time of the reactants in the reactor is adjusted via the speed of the pumps on the supply unit.

The conversion in the plug-flow reactor is determined by measuring the conductivity. A combined conductivity/temperature sensor is included in CE 310. Conductivity and temperature are digitally displayed on the switch cabinet of the supply unit. In addition, the measured values can be captured and processed with data acquisition software (included in CE 310).

CE 310.05 Plug-flow reactor

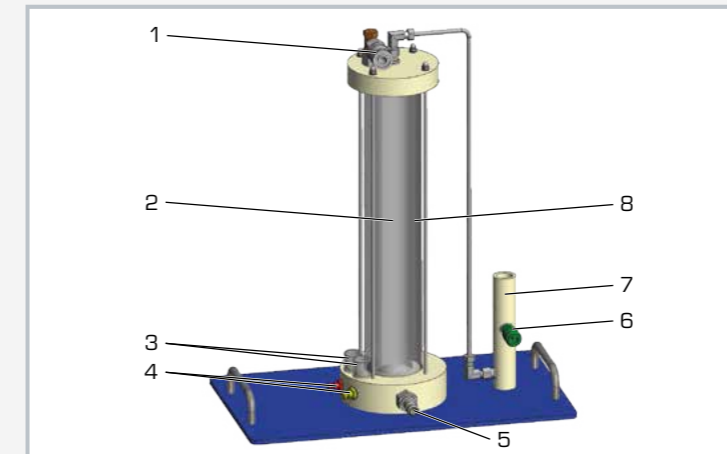

1 water drain, 2 reactor with fixed bed, 3 air vessel, 4 reactants A/B supply, 5 water supply, 6 product drain, 7 sleeve for sensor for conductivity and temperature (included in CE 310), 8 double jacket for water

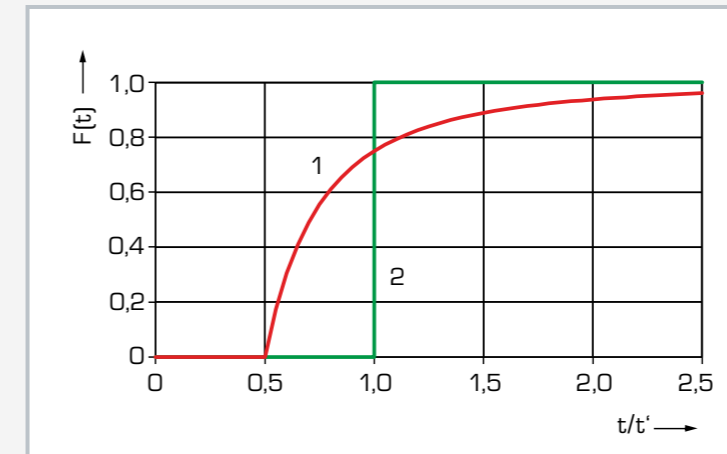

1 laminar flow, 2 plug-flow; $F(t)$ retention time cumulative curve, t time, t' retention time

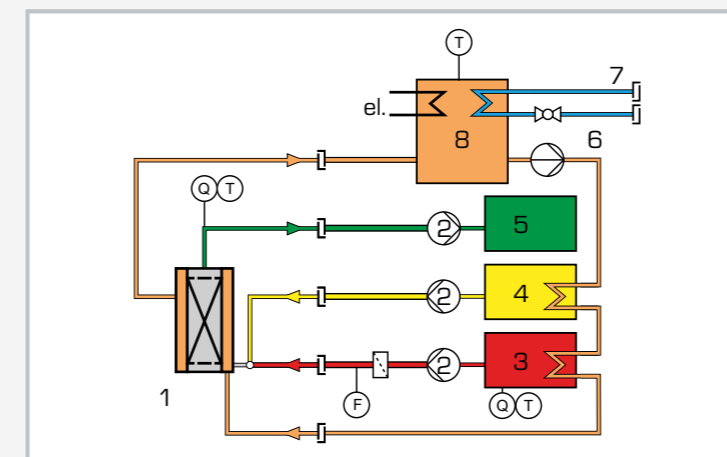

Process schematic with supply unit CE 310

1 plug-flow reactor, 2 peristaltic pump, 3 reactant A tank, 4 reactant B tank, 5 product tank, 6 water pump, 7 water connection, 8 water tank; Q conductivity, F flow rate, T temperature

Specification

- [1] plug-flow reactor for connection to supply unit CE 310
- [2] air vessel for damping of pulsation
- [3] T-piece with nozzle for mixing the reactants
- [4] straight glass tube with fixed bed from glass spheres as reactor
- [5] transparent double jacket from PMMA for cooling and heating with CE 310 and WL 110.20
- [6] sensor for measuring the conductivity and temperature via CE 310
- [7] temperature control in the reactor via CE 310

Technical data

Plug-flow reactor

- inside diameter: 40mm
- height: 400mm
- material: glass

Water bath

- inside diameter: 70mm
- capacity: approx. 0,4L
- material: PMMA

LxWxH: 440x250x530mm

Weight: approx. 15kg

Scope of delivery

- 1 plug-flow reactor

CE 310.06

Laminar flow reactor



Learning objectives/experiments

- fundamentals of a saponification reaction
- continuous operation
- conversion depending on
 - ▶ retention time
 - ▶ temperature
 - ▶ concentration
- retention time distribution



Description

- reactor with laminar flow for connection to supply unit CE 310
- continuous operation
- transparent materials to observe the process
- isothermal operation
- determination of the conversion in a saponification reaction

Reactors with laminar flow are tubular reactors and are operated continuously. They allow analyses of chemical reactions under defined flow conditions with the characteristic retention time distribution.

CE 310.06 is part of a device series that enables experiments with different reactor types. In conjunction with the supply unit CE 310, it is possible to examine the function and behaviour of a reactor with laminar flow in continuous operation.

The supply unit CE 310 has a heating water circuit as well as all necessary connections, pumps, tanks for reactants and a product tank. In combination with WL 110.20 Water Chiller and the supply unit CE 310 it is also possible to cool the reactors.

CE 310.06 is mounted onto the supply unit and held by two pins in position. Quick-release couplings enable easy connection of the reactor to the supply unit.

In continuous operation, two pumps on the supply unit deliver the reactants into the reactor. Due to the dimensions and possible volume flows laminar flow is formed. The product is formed by reaction of the reactants. The mixture of product and unconverted reactants leaves the reactor after a specific retention time through the upper end.

The mixture is transported into a tank of the supply unit via an additional peristaltic pump.

The retention time of the reactants in the reactor is adjusted via the speed of the pumps on the supply unit.

The conversion in the laminar flow reactor is determined by measuring the conductivity. A combined conductivity/temperature sensor is included in CE 310. Conductivity and temperature are digitally displayed on the switch cabinet of the supply unit. In addition, the measured values can be captured and processed with data acquisition software (included in CE 310).

CE 310.06

Laminar flow reactor

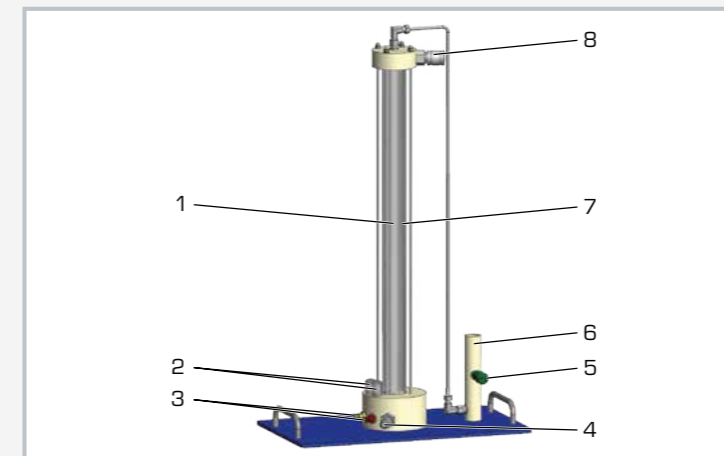

1 reactor with fixed bed, 2 air vessel, 3 reactants A/B supply, 4 water supply, 5 product drain, 6 sleeve for sensor for conductivity and temperature (included in CE 310), 7 double jacket for water, 8 water drain

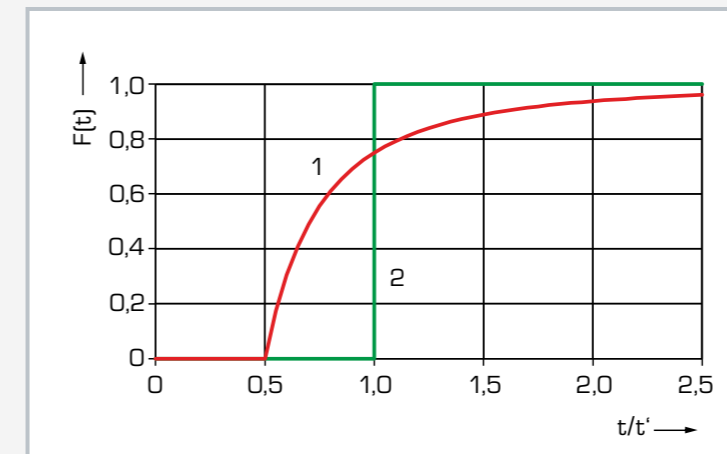

1 laminar flow, 2 plug-flow; F(t) retention time cumulative curve, t time, t' retention time

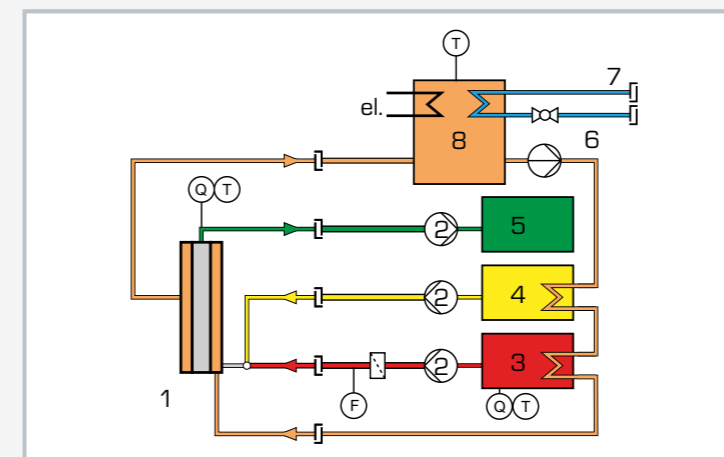

Process schematic with supply unit CE 310
1 laminar flow reactor, 2 peristaltic pump, 3 reactant A tank, 4 reactant B tank, 5 product tank, 6 water pump, 7 water connection, 8 water tank; Q conductivity, F flow rate, T temperature

Specification

- [1] laminar flow reactor for connection to supply unit CE 310
- [2] air vessel for damping of pulsation
- [3] T-piece with nozzle for mixing the reactants
- [4] special inlet for reducing the inlet length
- [5] straight glass tube with laminar flow
- [6] transparent double jacket from PMMA for cooling and heating with CE 310 and WL 110.20
- [7] sensor for measuring the conductivity and temperature via CE 310
- [8] temperature control in the reactor via CE 310

Technical data

Laminar flow reactor
 ■ inside diameter: 15mm
 ■ height: 600mm
 ■ material: glass

Water bath
 ■ inside diameter: 45mm
 ■ capacity: approx. 0,45L
 ■ material: PMMA

LxWxH: 440x250x750mm
 Weight: approx. 10kg

Scope of delivery

- 1 laminar flow reactor

CE 100 Tubular reactor



Description

- tubular reactor with temperature control
- saponification reaction with conductivity measurement to determine the conversion rate
- preheating of the reactants

Tubular reactors are continuously operated reactors. Tubular reactors make possible the cost-effective production of large product quantities with consistent quality.

The main component of CE 100 is the tubular reactor with ten temperature-controlled sections. Two pumps convey the reactants from the receiving tanks into the preheating sections and then into the reactor. The preheating sections consist of a coiled tube located in the hot water tank. After preheating, the reactants are mixed just before they enter the reactor. The electrical conductivity of the reaction mixture is measured at the inlet, in the centre and at the outlet of the reactor. While the reaction mixture flows through the reactor, the reactants react to the products. The mixture of products and unreacted reactants leaves the reactor and is collected in a tank.

The volumetric flow rates of the reactants and thus also the retention time in the tubular reactor are adjusted at the pumps. The ten sections of the tubular reactor consist of tubular heat exchangers. The reaction mixture flows in the inner tube of the heat exchanger and the hot water flows in the outer tube. This hot water circuit is temperature controlled. The controller on the switch cabinet makes it possible to set the desired temperature and displays the current temperature in the hot water tank. Three stirring machines ensure uniform mixing and temperature distribution in the reactant tanks and in the hot water tank.

Sensors record the temperatures and electrical conductivities. The measured values are read from digital displays and can be transmitted simultaneously via USB directly to a PC where they can be analysed using the software. The reaction is analysed using the measured electrical conductivities and the conversion rate calculated from this.

Learning objectives/experiments

- fundamentals of a saponification reaction
- conversion rate
 - ▶ as a function of retention time
 - ▶ as a function of temperature
 - ▶ as a function of reaction order

CE 100 Tubular reactor



1 switch cabinet, 2 reactant pumps with volumetric flow rate measurement, 3 reactant tank, 4 hot water tank, 5 pump, 6 product tank, 7 measurement of temperature and electrical conductivity, 8 tubular reactor with 10 sections

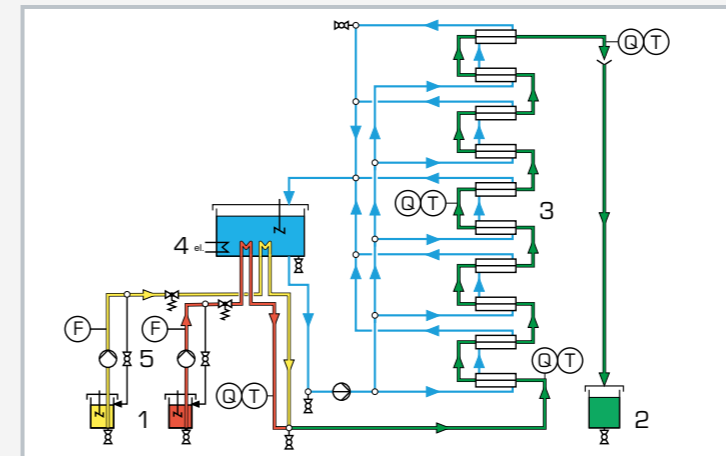

1 reactant tank, 2 product tank, 3 tubular reactor with 10 sections, 4 heater, 5 reactant pumps, F flow rate, Q electrical conductivity, T temperature

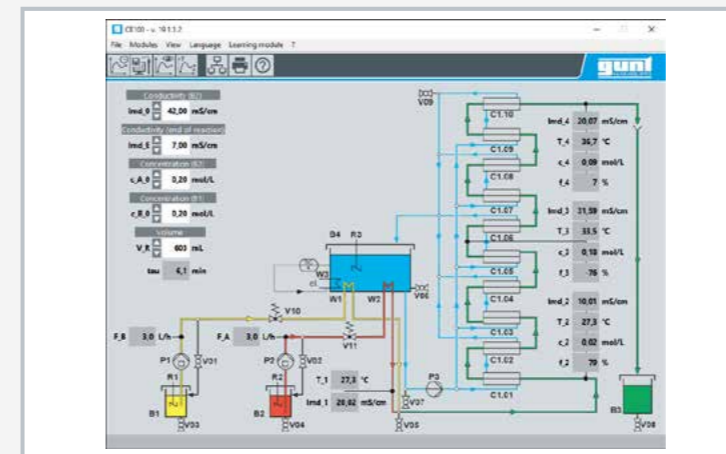

Software screenshot

Specification

- [1] continuous tubular reactor to carry out a saponification reaction
- [2] 10 tubular heat exchangers as reactor
- [3] 2 identical pumps to convey the reactants
- [4] adjustment of the volumetric flow rates of the reactants at the pumps
- [5] preheating of the reactants with 2 stainless steel coiled tubes
- [6] T-piece for mixing the preheated reactants
- [7] hot water tank with temperature control
- [8] measurements for electrical conductivity: at the inlet, centre and at the outlet of the reactor
- [9] measurement of conductivity and temperature with 3 combined sensors
- [10] GUNT software for data acquisition via USB under Windows 8.1, 10

Technical data

Tubular reactor

- Ø inner: approx. 8mm
- reactor volume: approx. 0,6L
- material: 1.4571

Reactant pump

- max. flow rate: 0,3L/min
- max. head: 20m

Tanks

- reactants: 2x 25L
- products: 1x 50L
- water: 1x 30L

Hot water circuit

- heater power: approx. 4kW
- temperature: max. 55°C

Stirring machines speed: max. 310min⁻¹

Measuring ranges

- volumetric flow rate: 2x 2...320mL/min
- temperature: 4x 0...80°C
- conductivity: 3x 0...100mS/cm

400V, 50Hz, 3 phases

400V, 60Hz, 3 phases, 230V, 60Hz, 3 phases

UL/CSA optional

LxWxH: 1900x790x1950mm

Weight: approx. 290kg

Required for operation

Ethyl acetate, caustic soda (for saponification reaction)
PC with Windows recommended

Scope of delivery

- 1 experimental unit
- 1 set of accessories
- 1 set of instructional material



Visit
our website

On our website you will find all you need to know,
including all the latest news.

Basic knowledge Catalytic activation

Many reactions are too slow for technical applications at ambient temperature because the required activation energy is very high. Catalysts lower the required activation

energy and accelerate the chemical reaction. Thus, some reactions would not be possible without a catalyst reducing the energy required for production.

According to Wilhelm Ostwald, a catalyst is any substance that changes the speed of a reaction without appearing in the end product. Catalysis can be understood as the acceleration of a chemical reaction by means of a catalyst. Catalysts are used in approximately 80% of all industrial chemical processes.

In the simple case of the reaction of a reactant **A** to a product **P** by means of a catalyst **K**, one can imagine that the catalysis occurs via an intermediate product **X**. The reactant and the catalyst thus first form an intermediate product. In a second step, the catalyst is released and the intermediate product is converted to form the product **P**. The catalyst is unchanged after the reaction and is available again for further reactions.

One possible explanation of catalysis is the theory of the transition state. This theory assumes that the reactants involved in the reaction have to cross an energy barrier for the reaction to take place. The molecular state at the maximum of the energy barrier E_1 is referred to as activated complex. The products form directly from this molecular state. During catalysis, the activated complex is formed from the reactants and the catalyst. The energy E_2 , which is required to form the complex with the catalyst, is lower than the energy E_1 which would be required without the catalyst. This lower energy requirement means that a larger number of reactants react per time unit to form products, i.e. the reaction rate is higher.

There are two types of catalysis:

■ Homogeneous catalysis

The catalyst and the starting substances of the chemical reaction are in the same phase. This means that the reaction takes place either in the liquid or in the gaseous phase. In the liquid phase, the properties of the solvent (e.g. viscosity) also influence the reaction rate in addition to the type of reactants and catalyst.

■ Heterogeneous catalysis

The catalyst is in the solid phase in most cases. The starting substances of the reaction are in the liquid or gaseous phase. In addition to the actual chemical reaction between reactants and catalyst, processes such as diffusion inside the solid catalyst and sorption processes have a significant influence on the reaction rate.

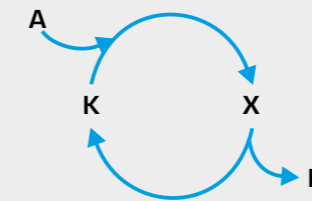

Reaction schematic of a simple catalytic reaction as a schematic (top) and cycle (bottom):

A reactant, **K** catalyst, **X** intermediate product,
P product

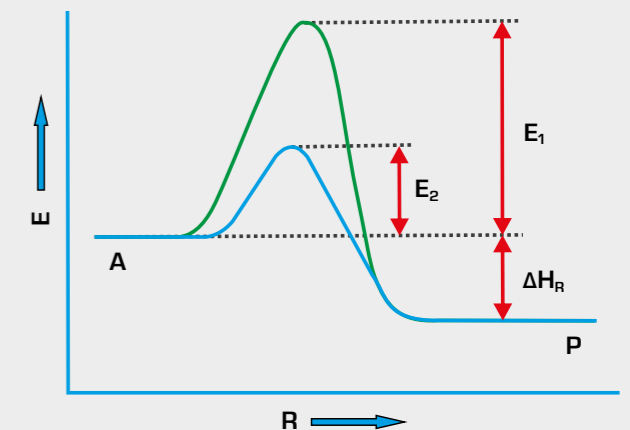

Energy change with and without catalyst (exothermic):

E energy, **R** reaction coordinate,
 E_1 energy required to form an activated complex without catalyst,
 E_2 energy required to form an activated complex with catalyst,
 ΔH_R reaction enthalpy

Overview

CE 380 Fixed bed catalysis

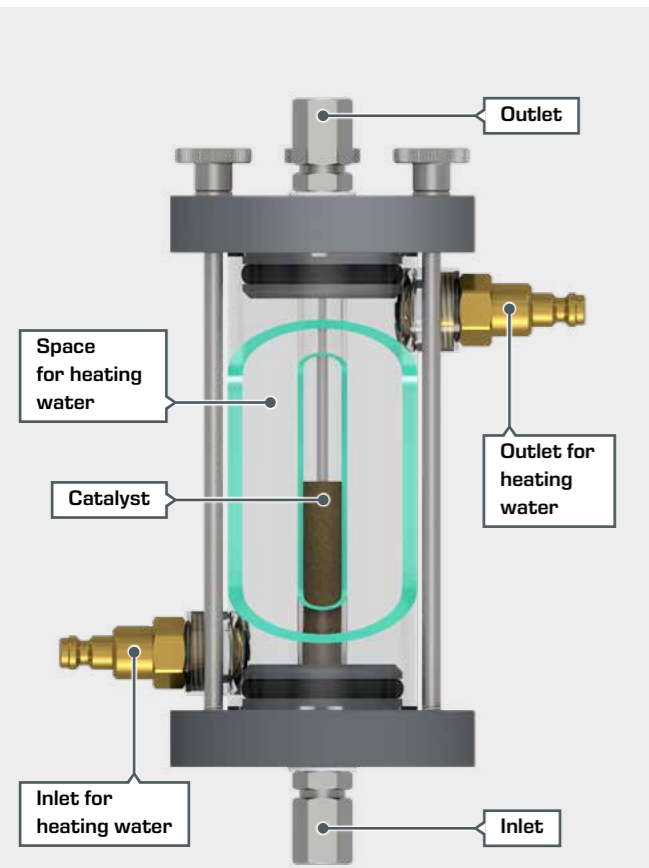

Design of the fixed bed reactors

Chemical reactions are often carried out with catalysts. Catalysts accelerate chemical reactions or make them possible in the first place. Catalysts reduce the required activation energy or produce temporary compounds for other reaction paths. Catalysts emerge from the reactions unchanged and are therefore available again for the next reaction.

In **fixed bed catalysis**, the catalyst is present as a fixed bed in a reactor. The flow through with the starting substances (educts) and the reaction in the fixed bed take place continuously. This enables consistent reaction conditions and a higher product yield.

The main components of CE 380 are three fixed bed reactors. This makes it possible to create three experimental setups, each with different catalyst quantities, for example. The reactors are designed as double tubes, with the catalyst located in the inner tube. The area between the two tubes is used to heat the reactors with hot water. The flow rate of the starting solution, and thus the hydraulic detention time in the reactor, can be adjusted continuously.

Learning objectives

- fundamentals of chemical catalysis
- dependence of the reaction on
 - ▶ catalyst mass
 - ▶ temperature
- use of a photometric analyser
- drawing up a quantity balance
- determining yield

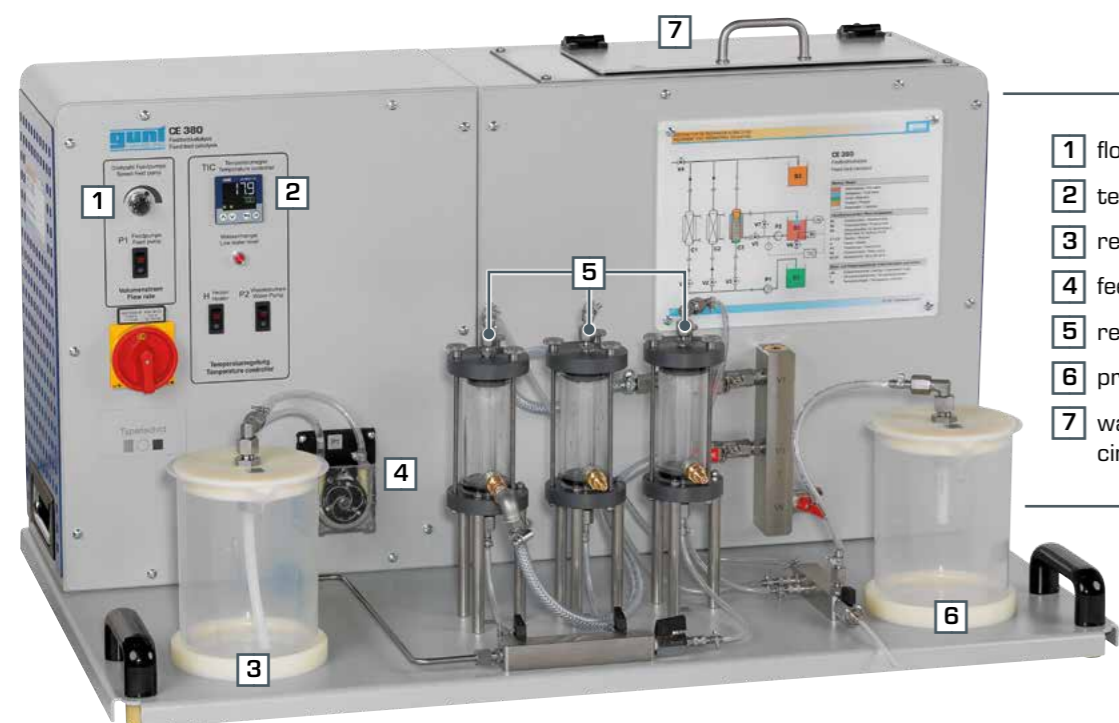

- 1 flow control
- 2 temperature controller
- 3 reactant tank
- 4 feed pump
- 5 reactors
- 6 product tank
- 7 water tank for heating circuit

About the product:



Catalysed hydrolysis of sucrose

Hydrolysis generally refers to the splitting of a chemical compound by reaction with water. An example of this is the decomposition of sucrose into glucose and fructose. This reaction also requires a catalyst. Although glucose and fructose have the same molecular formula, they differ in terms of how the individual atoms are arranged.

The CE 380 device is designed for the hydrolysis of sucrose into glucose and fructose. A strongly acidic ion exchanger, which is included with the device, serves as a catalyst.

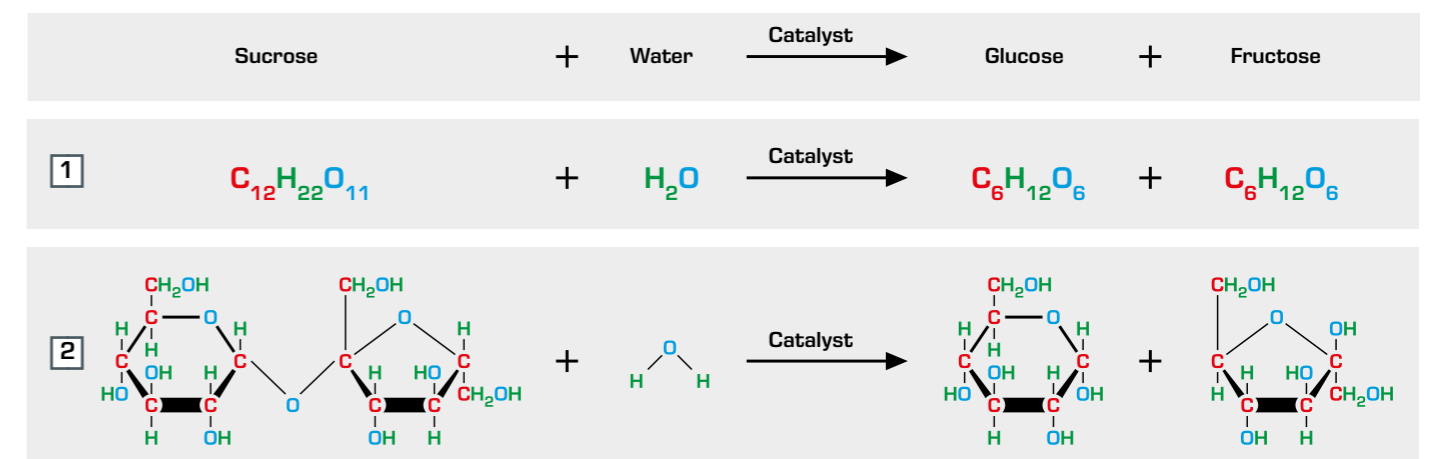

Hydrolysis of sucrose: 1 reaction equation and 2 Haworth projections

Experiment evaluation with photometer

The conversion rate is an important parameter for evaluating chemical reactions. With CE 380, this is done by determining the glucose concentration in the reaction product. To do this, an iodine-starch complex is first prepared from the product solution using various chemicals. A blue colour is characteristic for an iodine-starch complex. The intensity of the colour is a measure of the glucose concentration.

The iodine-starch complex absorbs light in the yellow-orange range, so that the glucose concentration can be determined photometrically. Therefore the device is supplied with a photometer to allow analysis of the experiments. The data from the photometer is transmitted directly to a PC where it can be analysed using a software.

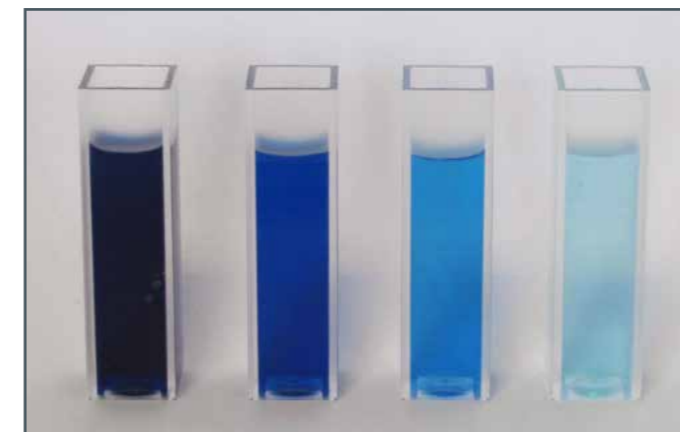

Iodine-starch complexes with decreasing glucose concentration from left to right



Photometer for analysing the experiment

CE 380

Fixed bed catalysis



Description

- chemical fixed bed catalysis
- three reactors for comparative experiments
- product analysis with photometer

Catalysts enable or accelerate chemical reactions. CE 380 is designed for the decomposition reaction of dissolved saccharose in glucose and fructose.

A peristaltic pump transports the reactant (saccharose solution) into bottom of the reactor from a tank. The catalyst takes the form of a fixed bed in the reactor. The saccharose solution flows through the fixed bed. In the process, saccharose is decomposed into glucose and fructose. The catalyst accelerates the reaction and so increases the yield of the product (glucose/fructose mixture). The product is collected in a tank.

Three reactors allow various catalyses to be compared. The chemical catalyst used is exchanger resin. A regulated heating water circuit additionally permits analysis of the influence of temperature on the reaction.

To determine the glucose concentration in the product, a photometer specifically adapted to the unit is supplied. The photometer data are transferred to a PC and evaluated by software. The flow injection analysis (FIA) CE 380.01 is available as an optional accessory. The FIA enables a larger number of measurements to be performed during the experiment compared to manual analysis, while at the same time reducing the effort involved and improving reproducibility.

Learning objectives/experiments

- fundamentals of chemical catalysis
- dependence of the reaction on
 - ▶ catalyst mass
 - ▶ temperature
- use of a photometric analyser
- drawing up a quantity balance
- determining yield

CE 380

Fixed bed catalysis

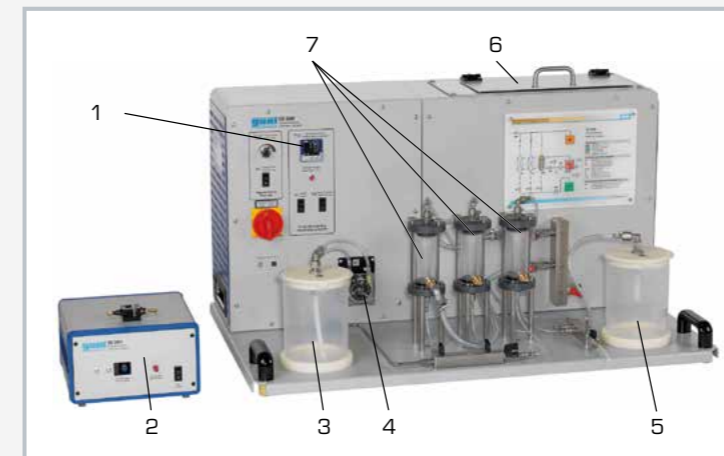

1 temperature controller, 2 photometer, 3 reactant tank, 4 feed pump, 5 product tank, 6 water tank for heating circuit, 7 reactor

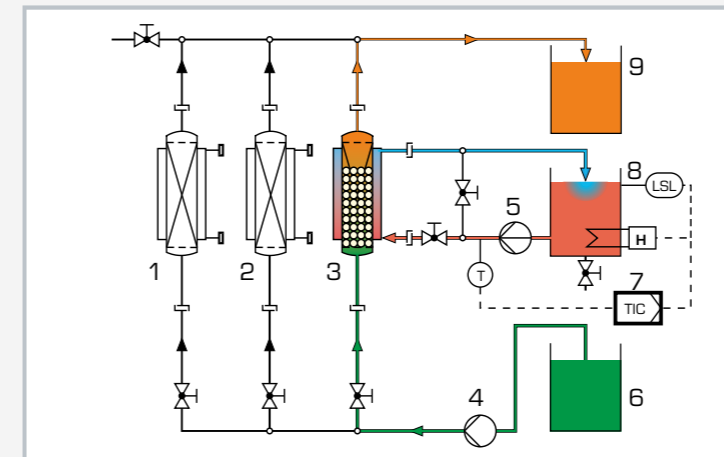

1-3 reactor, 4 feed pump, 5 heating circuit pump, 6 reactant tank, 7 temperature controller, 8 water tank with heater and level switch, 9 product tank



Photometer: 1 cuvette holder, 2 light source connection, 3 spectrometer connection

Specification

- [1] investigation of a catalytic reaction
- [2] 3 reactors (PMMA) for comparison of various fixed bed catalyses
- [3] peristaltic pump with adjustable speed to transport the reactant into the reactors
- [4] regulated heating circuit with water tank, heater and pump to regulate the reactor temperatures
- [5] 1 scaled container for reactant and product respectively
- [6] photometer for analysis of the product
- [7] GUNT software for data acquisition via USB under Windows 8.1, 10 (photometer)
- [8] flow injection analysis (CE 380.01) available as accessory

Technical data

Reactors

- diameter: approx. 10mm
- height: approx. 120mm

Peristaltic pump

- max. flow rate: approx. 50mL/min

Heating circuit pump

- max. flow rate: 10L/min
- max. head: 30m
- power consumption: 120W

Heating circuit

- tank: approx. 7500mL
- heater: approx. 1kW

Tanks for reactant and product

- capacity: approx. 2000mL
- scale division: 50mL
- material: PP

Photometer wavelength: 610nm

230V, 50Hz, 1 phase
230V, 60Hz, 1 phase
120V, 60Hz, 1 phase
UL/CSA optional
LxWxH: 1000x680x500mm (experimental unit)
LxWxH: 260x260x180mm (photometer)
Weight: approx. 63kg

Required for operation

PC with Windows

Scope of delivery

- 1 experimental unit
- 1 photometer
- 1 packing unit of chemical catalyst
- 1 CD with software for photometer
- 1 set of accessories
- 1 set of instructional material

CE 380.01

Flow injection analysis



Description

- professional analyser for CE 380
- continuous photometric determination of the glucose concentration

The flow injection analysis (FIA) supplements CE 380. It uses the photometer in CE 380 as a detector to detect the reaction product glucose.

The multi-channel pump permanently conveys three liquid flows into the FIA. The dissolved reaction products from CE 380 and an indicator reagent are first mixed in one chamber. The mixture then flows through a helical reaction loop. The conduction of the flow in the reaction loop enables an even distribution of all substances.

Another indicator reagent is added in a second mixing chamber. After flowing through another reaction loop, the mixture enters the flow cell. There the light intensity is continuously measured with the photometer to determine the glucose concentration. To trigger the discoloration for the photometric measurement, a defined amount of the enzyme glucose oxidase (GOD) is injected through an injection valve. The indicator reagents and the enzyme GOD are not included in the scope of delivery.

CE 380.01 enables more measurements during the experiment than a manual analysis. In addition, the reproducibility is improved and it is no longer necessary to mix each individual sample.

Learning objectives/experiments

- using the flow injection analysis (FIA)
- determining the concentration
- determining the yield for CE 380

CE 380.01

Flow injection analysis

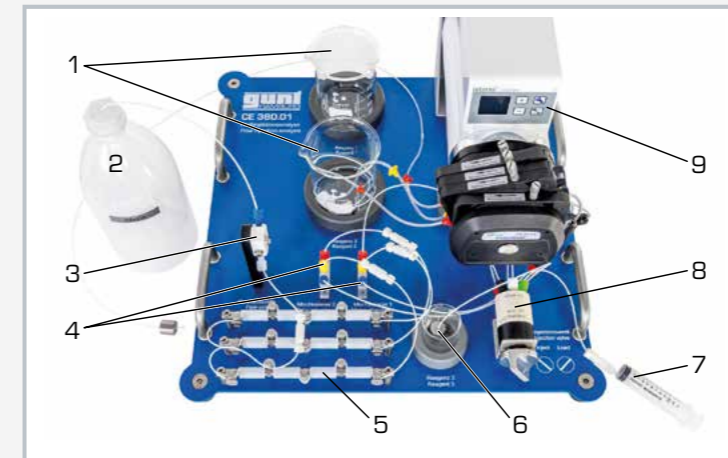

1 tanks for reagents 1 and 2, 2 waste, 3 flow cell, 4 mixing chambers, 5 reaction loop, 6 reagent 3 GOD, 7 injection syringe, 8 injection valve, 9 multi-channel peristaltic pump

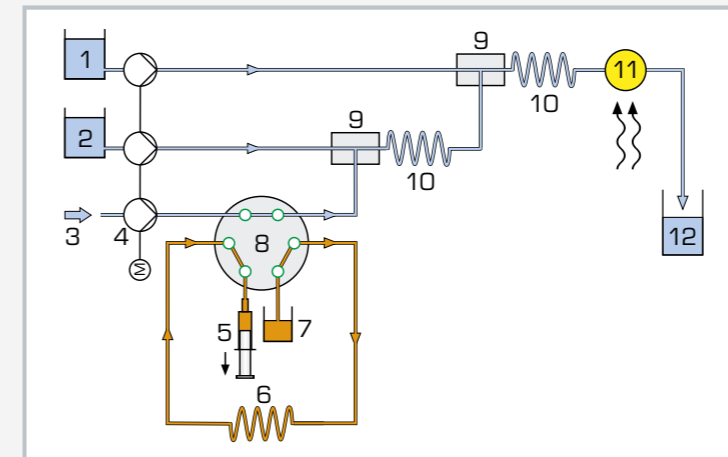

Filling the injection loop with GOD:
1 reagent 2, 2 reagent 1, 3 reaction products from CE 380, 4 multi-channel peristaltic pump, 5 injection syringe, 6 injection loop, 7 reagent 3 GOD, 8 injection valve, 9 mixing chambers, 10 reaction loops, 11 flow cell, 12 waste

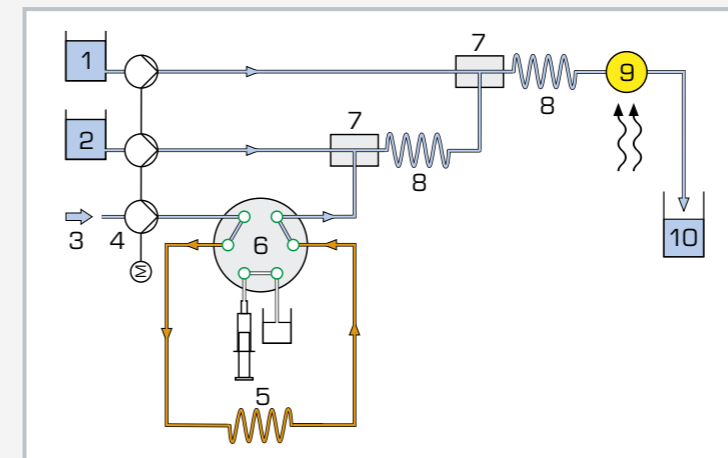

Injecting GOD:
1 reagent 2, 2 reagent 1, 3 reaction products from CE 380, 4 multi-channel peristaltic pump, 5 injection loop, 6 injection valve, 7 mixing chamber, 8 reaction loop, 9 flow cell, 10 waste

Specification

- [1] continuous, photometric determination of the glucose concentration in the product from CE 380
- [2] PTFE flow cell for determining the concentration with the photometer from CE 380
- [3] multi-channel peristaltic pump for conveying the product from CE 380 and the indicator reagents
- [4] injection valve, injection syringe and injection loop for adding the enzyme GOD required for verification
- [5] 2 mixing chambers for mixing the product and indicator reagents
- [6] 2 PTFE reaction loops
- [7] 3 DURAN glass beakers for indicator reagents and GOD
- [8] tank for waste

Technical data

Flow cell travel length: 1 cm

Multi-channel peristaltic pump

- 4 channels
- max. flow rate per channel: 1.1 mL/min at 100min⁻¹ and hose $D_i=1,42\text{mm}$

Injection valve

- 6 connections
- 2 switch positions

Loops

- reaction loops: 1x 2000mm, 1x 4000mm
- injection loop: 1x 100mm

Tanks

- indicator reagents: 2x 250mL
- GOD: 1x 25mL
- waste: 1x 1000mL
- injection syringe: 1x 10mL

230V, 50Hz, 1 phase
230V, 60Hz, 1 phase
120V, 60Hz, 1 phase
UL/CSA optional
LxWxH: 400x400x200mm
Weight: approx. 8kg

Scope of delivery

- 1 experimental unit
- 1 set of hoses
- 1 set of accessories
- 1 manual

CE 650 Biodiesel plant



screen mirroring is possible on different end devices

Description

- chemical transesterification
- two-stage process
- plant controlled via PLC and touch panel
- integrated router for operation and control via an end device and for screen mirroring on additional end devices: PC, tablet, smartphone

The use of renewable energy carriers in the mobility sector can happen by replacing fossil fuels. One option is biodiesel, which is obtained from vegetable oils. It is produced by adding methanol and potassium hydroxide (as catalyst) and is a transesterification, a chemical equilibrium reaction. On a large industrial scale, production is carried out continuously in stirred tank reactors. This process is demonstrated on a small scale by the CE 650 experimental plant.

The chemical reaction takes place at temperatures of around 60°C. The products leave the reactor after a pre-defined dwell time. The products are a two-phase mixture: A biodiesel-rich phase and a phase with by-products. The by-products are pumped out of the following phase separator. The options for the biodiesel-rich phase are: Return to the reactor, second transesterification stage, methanol recovery (distillation)

and biodiesel washing (absorption).

The biodiesel-rich phase contains residual amounts of methanol, potassium hydroxide and vegetable oil, in addition to the biodiesel. The remaining vegetable oil is reacted in the second transesterification stage. The methanol is distilled off in the methanol recovery stage. Residual amounts of the catalyst are removed in the biodiesel washing stage. Then the products are stored.

The rate of transesterification is dependent on the reaction time and the temperature. The chemical equilibrium is shifted by the separation of the by-products. The biodiesel produced is analysed in the laboratory. The process parameters can be varied to investigate the dependencies.

The experimental plant is controlled by a PLC via touch panel. By means of an integrated router, the system can alternatively be operated and controlled via an end device. The user interface can also be displayed on additional end devices (screen mirroring). Via the PLC, the measured values can be stored internally. Access to stored measured values is possible from end devices via WLAN with integrated router/LAN connection to the customer's own network.

Learning objectives/experiments

- production of biodiesel from vegetable oil
 - ▶ influence of dwell time
 - ▶ influence of temperature
- chemical transesterification
- phase separation in the gravity field
- distillation
- liquid-liquid extraction
- approach of a continuous process consisting of several basic operations
- screen mirroring: mirroring of the user interface on end devices
 - ▶ menu navigation independent of the user interface shown on the touch screen
 - ▶ different user levels available on the end device: for observing the experiments or for operation and control

CE 650 Biodiesel plant

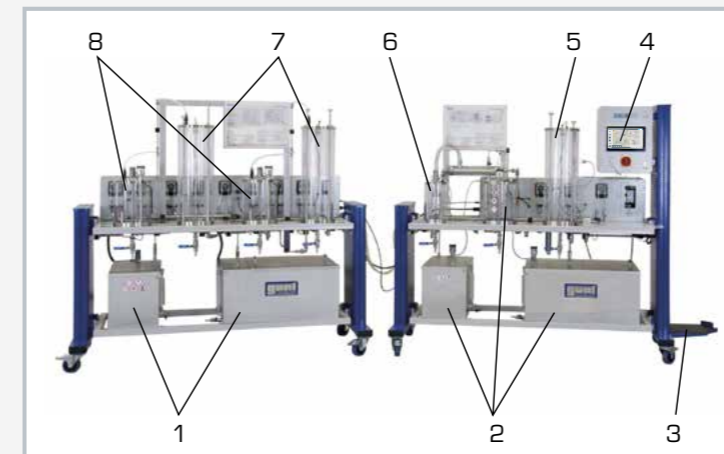

1 storage tank, 2 storage, 3 gas cylinder holder, 4 PLC with touch panel, 5 biodiesel washer, 6 methanol recovery, 7 phase separator, 8 reactor

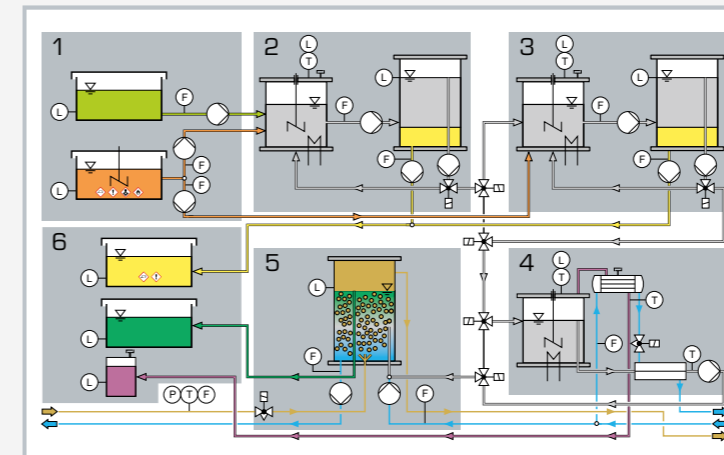

Process schematic of the experimental plant
1 supply, 2 transesterification 1st stage, 3 transesterification 2nd stage, 4 methanol recovery, 5 biodiesel washing, 6 storage



Start screen of the PLC for operation of the experimental plant

Specification

- [1] chemical transesterification of vegetable oils
- [2] two-stage, continuous process
- [3] two heated stirred tank reactors for chemical transesterification
- [4] two phase separators for separating products and by-products
- [5] methanol recovery (distillation) to reduce the amount of methanol required
- [6] biodiesel washing (absorption) to extract impurities from the biodiesel
- [7] variation of process parameters to investigate the dependencies of biodiesel production
- [8] PLC for controlling the plant
- [9] touch panel for operating the PLC
- [10] data acquisition via PLC on internal memory, access to stored measured values via WLAN with integrated router/LAN connection to customer's own network

Technical data

PLC: Eaton XV303

Tanks

- stirred tank reactors: 2x 5L
- storage tank (vegetable oil): 110L
- storage tank (chemicals): 45L
- product tank: 110L
- by-product tank: 45L
- methanol tank: 6L
- phase separator/biodiesel washer: 3x 15L

Peristaltic pumps: max. 25L/h

Measuring ranges

- temperature: 6x 0...100°C
- pressure: 1x 0...6bar (abs.)
- flow rate: 11x 0...30L/h
- level:
 - ▶ 3x 1...22cm
 - ▶ 2x 1...29cm

230V, 50Hz, 1 phase
230V, 60Hz, 1 phase; 120V, 60Hz, 1 phase
UL/CSA optional
1x LxWxH: 1900x790x1700mm
1x LxWxH: 2200x790x1700mm
Weight: approx. 560kg

Required for operation

vegetable oil, potassium hydroxide, methanol, nitrogen 0,06kg/h, min. 2bar; water connection + drain 400L/h, min. 2bar; exhaust air + ventilation 245m³/h

Scope of delivery

- 1 experimental plant
- 1 set of instructional material

Basic knowledge

Photochemical activation

In a photochemical activation, the activation energy to enable or accelerate the reaction is applied by means of electromagnetic radiation. When the atoms or molecules absorb this radiation, they achieve a higher energy level and are activated. For an effective reaction process, the emission spectrum (wavelength range) of the light source used has to be as similar to the absorption spectra of the reacting substances as possible.

In industrial-scale photochemical reactions, the electromagnetic radiation leads to the formation of radicals. The most important property of radicals is that they have an unpaired valence electron instead of an electron pair. This electron gives the radical its great reactivity and enables the reaction rates necessary for the industrial process. One advantage of photochemical activation is the possibility to activate specific chemical bonds by selecting a suitable emission spectrum. Another advantage is the fact that the reaction rate can be easily influenced by switching light sources on or off.

The following applications are examples of the industrial use of photochemical reactions:

- chlorination of hydrocarbons
- vitamin D production
- polyvinyl chloride (PVC) production
- treatment of wastewater contents

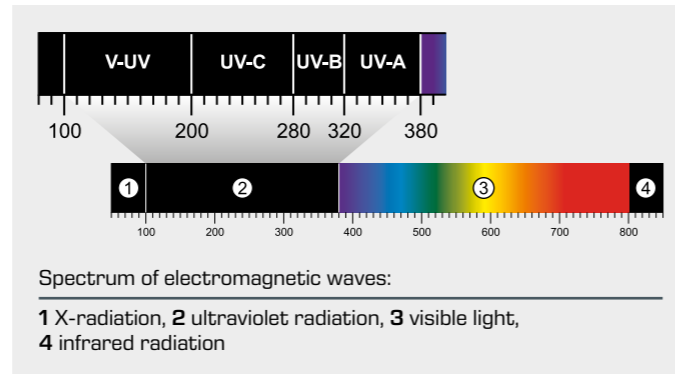

The electromagnetic radiation is mostly generated by means of lamps working according to the electric discharge principle. The gas used is normally mercury vapour.

The following lamp types are generally distinguished:

- **Low-pressure lamps**
These lamps generate a nearly monochromatic light (light of a single wavelength) with a wavelength of 254 nm (UV-C).
- **Medium-pressure lamps**
These lamps emit radiation of various wavelengths in the UV range and in the visible range. The emission spectrum is in the range of 200...600 nm.
- **High-pressure lamps**
The spectrum of these lamps ranges from the short-wave UV range (V-UV) far into the visible range. It is used in many photochemical reactions.

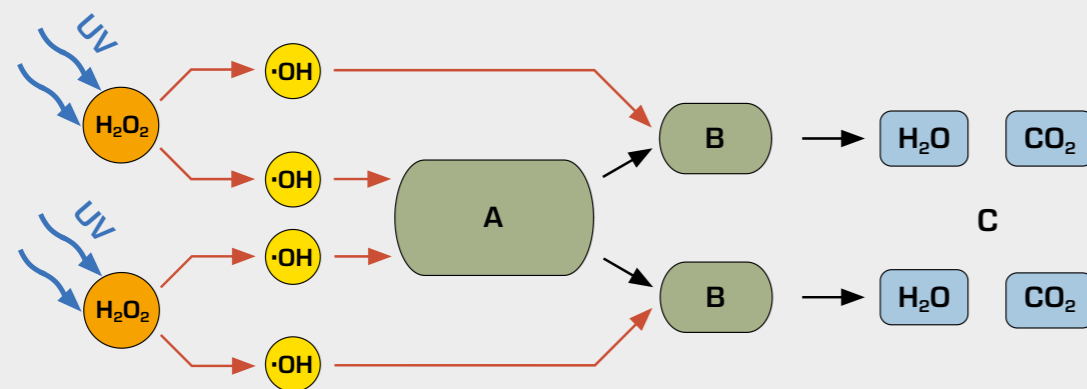

Example of a photochemically activated reaction to decompose organic, nonbiodegradable substances:

H_2O_2 hydrogen peroxide, $\cdot\text{OH}$ hydroxyl radical, **A** organic, nonbiodegradable substance, **B** organic intermediate products, **C** inorganic end products

Overview

CE 584 Advanced oxidation

Falling film reactor in batch mode

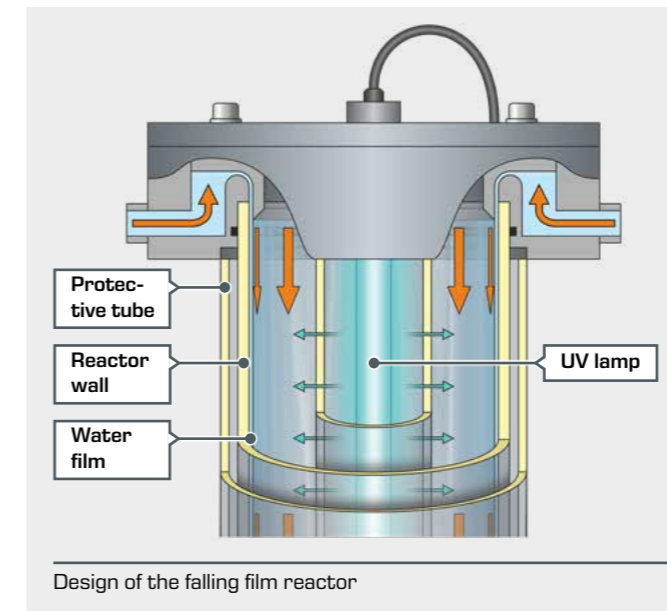

Advanced oxidation processes are state-of-the-art in water treatment. This device enables you to investigate the oxidation of non-biodegradable organic substances using hydrogen peroxide (H_2O_2) and UV radiation. The educational focus is on the experimental application of reaction kinetics relationships.

The main component of the device is a falling film reactor, which is operated discontinuously. The raw water mixed with hydrogen peroxide is pumped out of a tank into a channel at the upper end of the reactor. The water flows along the inner wall of the reactor, over an overflow edge, flows down as a thin film and finally ends up back in the tank. At the centre of the reactor there is a UV lamp. Irradiation with UV light (254 nm) causes the hydrogen peroxide to be split into the desired OH radicals.

Instructional material

The instructional material sets out the fundamentals of the process and the reaction kinetics relationships in detail. In addition, an experiment is described in detail and evaluated as an example.

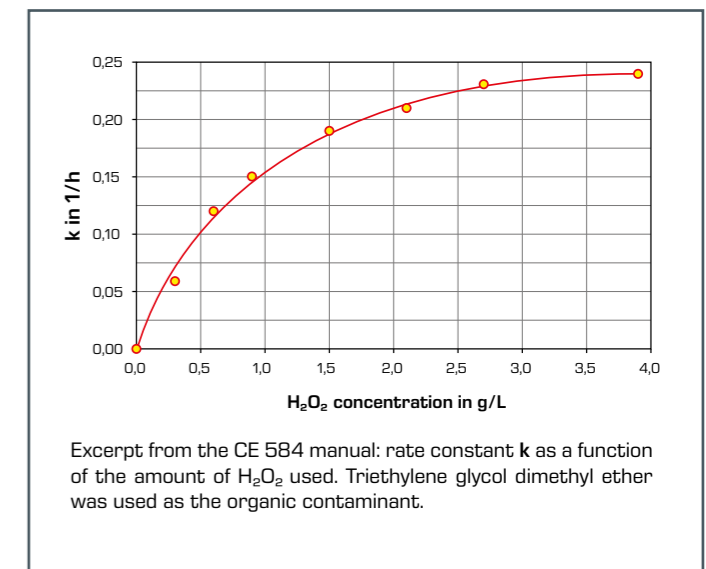

About the product:



Learning objectives

- plotting concentration time curves
- investigation of reaction kinetics
 - ▶ order of reactions
 - ▶ reaction rate
- effect of amount of H_2O_2 on the reaction progress

CE 584

Advanced oxidation



Learning objectives/experiments

- familiarisation with oxidation with hydrogen peroxide and UV light
- recording of degradation curves for the investigation of reaction kinetics
- influence of the hydrogen peroxide quantity on the process

2E

Description

- oxidation of organic substances with hydrogen peroxide (H_2O_2) and UV light
- discontinuous operation with falling film reactor

In water treatment oxidation processes are used to remove organic substances which are not biodegradable. If the oxidation is by hydroxyl radicals (OH radicals) it is called "advanced oxidation". A common method for forming hydroxyl radicals is the irradiation of hydrogen peroxide with UV light. CE 584 demonstrates this process using a discontinuous falling film reactor.

The falling film reactor consists of a transparent tube which is open at the bottom. At the top of the tube there is a circular channel.

Using a pump the raw water enriched with hydrogen peroxide is transported from a tank into the channel. From here the water flows as a thin falling film along the inside wall of the tube back into the tank. This creates a closed water circuit. At the centre of the tube there is a UV lamp. By irradiation of the falling raw water with UV light hydroxyl radicals form from the hydrogen peroxide molecules. The hydroxyl radicals oxidate the organic non-biodegradable substances in the raw water. As protection against the radiation the UV lamp is fitted with a protective tube.

The flow rate and temperature of the water are continuously measured. The temperature is indicated digitally in the switch cabinet. Samples can be taken at the tank.

E.g. triethylene glycol dimethyl ether can be used to produce the raw water. Analysis technology is required to evaluate the experiments.

CE 584

Advanced oxidation

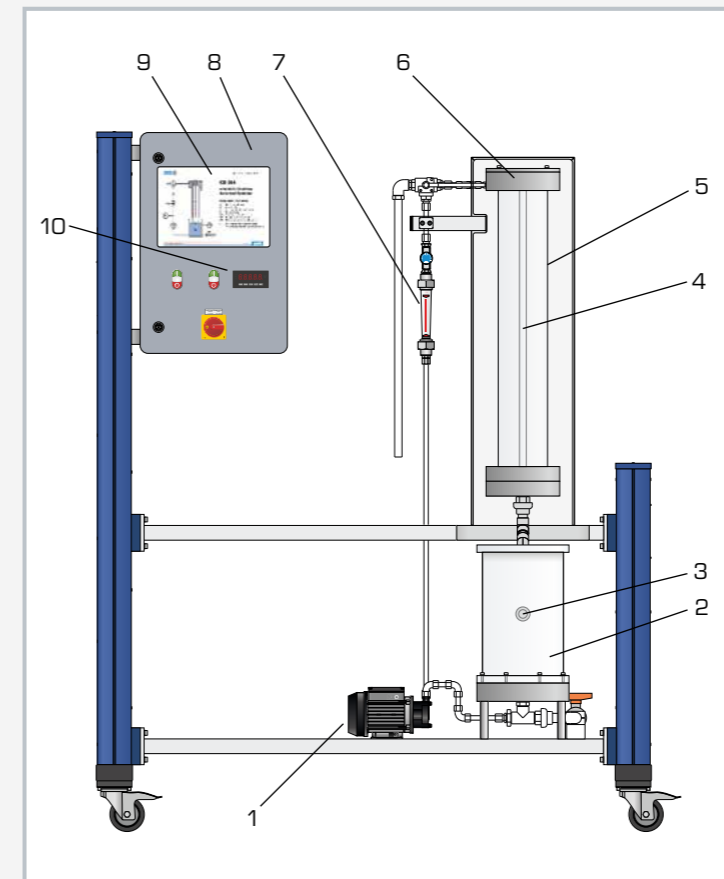

1 pump, 2 tank, 3 temperature sensor, 4 UV lamp with protective tube, 5 falling film reactor (tube), 6 channel, 7 flow meter, 8 switch cabinet, 9 process schematic, 10 digital temperature display

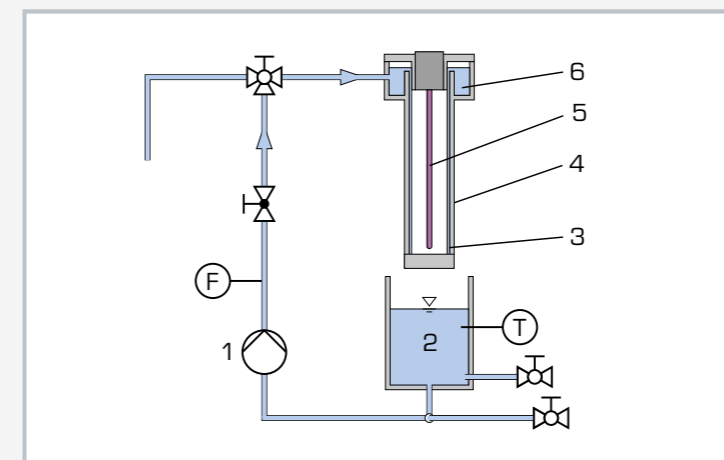

1 pump, 2 tank, 3 falling film, 4 falling film reactor (tube), 5 UV lamp, 6 channel; F flow rate, T temperature

Specification

- [1] advanced oxidation process
- [2] use of hydrogen peroxide and UV light
- [3] formation of hydroxyl radicals (OH radicals)
- [4] falling film reactor with UV lamp
- [5] discontinuous operation
- [6] flow rate adjustable
- [7] measurement of temperature and flow rate
- [8] digital temperature indication
- [9] protection device against UV radiation

Technical data

Falling film reactor (tube)

- diameter: 130mm
- height: 1000mm
- material: glass

UV lamp

- emitted wavelength: 254nm
- power: 120W

Pump

- max. flow rate: 360L/h
- max. head: 9m

Tank

- capacity: 10L

Measuring ranges

- flow rate: 30...320L/h
- temperature: 0...50°C

230V, 50Hz, 1 phase
230V, 60Hz, 1 phase; 120V, 60Hz, 1 phase
UL/CSA optional
LxWxH: 1510x790x1900mm
Weight: approx. 170kg

Required for operation

water connection, drain, hydrogen peroxide, triethylene glycol dimethyl ether (recommendation)

Scope of delivery

- 1 trainer
- 1 set of accessories
- 1 set of instructional material



Biological process engineering

Introduction

Overview The GUNT learning concepts of biological process engineering 172

Basic knowledge Biological processes and reactors 174

Aerobic processes

CE 701 Biofilm process 176

CE 704 SBR process 178

Overview CE 705 Activated sludge process 180

CE 705 Activated sludge process 182

Overview CE 730 Airlift reactor 184

CE 730 Airlift reactor 186

Anaerobic processes

Overview CE 702 Anaerobic water treatment 188

CE 702 Anaerobic water treatment 190

Basic knowledge Bioethanol 192

Overview CE 640 Biotechnical production of ethanol 194

CE 640 Biotechnical production of ethanol 196

Basic knowledge Biogas 198

CE 642 Biogas plant 200

Agents and reactor types in biological process engineering

This chapter contains experimental units that are suitable to familiarise students with the agents (e.g. microorganisms) and their living conditions. There are different reactor types in biological process engineering that are used to create these conditions. The programme offers a variety of options to learn about the operating principle, the areas of application and the differences of the common reactor types.

Working with the trainers requires experience, care, a suitable laboratory environment and time. Depending on the corresponding process and the substances used, sealed floors, drainage systems, water or compressed air supply, ventilation, secure storage facilities for the substances and microorganisms used, safety devices and protective clothing are required.

For the analysis of many experiments you will need professional analysis systems. These are not included in the scope of delivery of the GUNT training systems.

Please contact us. We will be happy to give advise.

The GUNT learning concepts of biological process engineering

What does biological process engineering deal with?

Biological process engineering deals with biological mass transformation. The following agents carry out this mass transformation:

- complete living organisms with one or a few cells, such as bacteria, fungi or algae
- biologically active, isolated components of organisms, such as animal or plant cells
- biologically active, isolated components of cells, such as enzymes

Biological process engineering has to create optimal conditions for these organisms, cells and cell components. The scientific findings from the areas of biology, biochemistry, etc. are implemented in industrial-scale processes. Examples of typical processes are:

- production of drugs
- production of chemicals
- production of food
- decontamination of soil, air and wastewater
- production of biomass energy sources

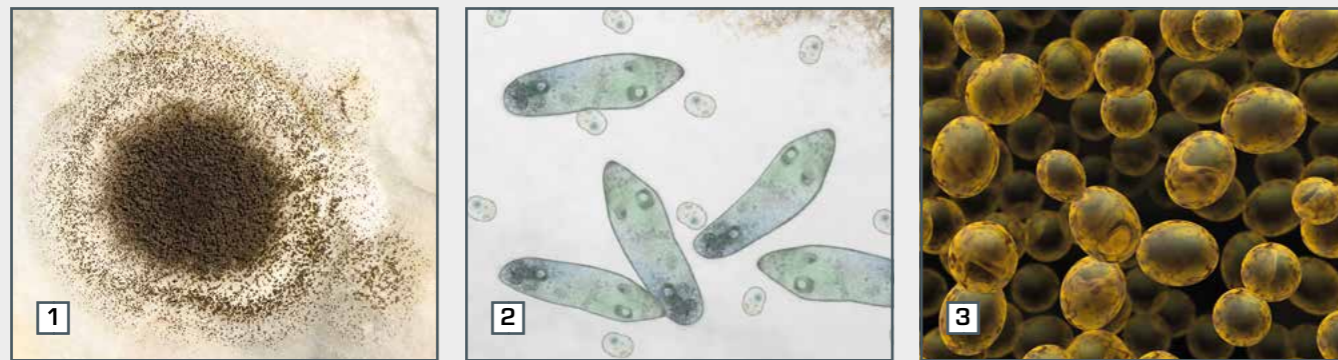

Examples of agents in biological process engineering:

1 *Aspergillus niger*: mould fungus used for the production of citric acid, 2 *Paramecium*: Microorganism for biological wastewater treatment, 3 *Saccharomyces cerevisiae*: yeast for the production of ethanol



Biological treatment stage on a wastewater treatment plant (aeration tank)

Our training systems for biological process engineering

Aerobic processes

- CE 701 Biofilm process
- CE 704 SBR process
- CE 705 Activated sludge process
- CE 730 Airlift reactor

Anaerobic processes

- CE 702 Anaerobic water treatment
- CE 640 Biotechnical production of ethanol
- CE 642 Biogas plant

Aerobic and anaerobic processes

An important distinguishing factor for biological processes is whether the microbiological processes take place under aerobic or anaerobic conditions. Biological process engineering has the task of creating the best possible ambient conditions for the respective microorganisms. In the case of fastidious anaerobic microorganisms this is the absence of oxygen. For aerobic microorganisms, on the other hand, an adequate and constant supply of oxygen must be ensured.

In the case of aerobic metabolism, the energy gain of the microorganisms is higher than during anaerobic metabolism. The aerobic microorganisms reproduce more quickly accordingly and there is more biomass.



PLC with touch screen



CE642 Biogas plant

Basic knowledge

Biological processes and reactors

Generally, a lot of different processes exist in process engineering. Each process is based on agents such as organisms, cells or enzymes. The respective agents are selected based the desired products and starting substances. The knowledge which agents are suitable for which application comes from basic disciplines like biology, biochemistry, etc. The knowledge which ambient

conditions are ideal for the agents in order to guarantee a high quality and quantity of the products also comes from these disciplines. The respective production process is developed based on this information. The individual steps are similar for many processes and their sequence.

Basic process steps

The starting substances are also called substrates. They can be pure substances such as sugar or alcohol. Often these substances first have to be gained from substrates such as molasses, spent mash, etc. and made available for the biological agents, for example by comminution.

Water, salts and nutrients are then added to achieve the best fermentation medium for the agents. The pH value often plays an important role in this process.

Many biological processes require the specific exclusion of foreign bacteria to hinder competing microorganisms and reactions. This means that the fermentation medium and the reactor have to be sterilised.

The actual production process (fermentation) takes place in the reactor, where agents such as organisms, cells and enzymes convert the starting substances to products. The reactor has to be exactly adjusted to the respective agents. In aerobic processes, for example, even distribution of oxygen in all areas is very important. Controlling the temperature by applying or dissipating heat is also important.

The fermentation medium leaving the reactor is a complex mixture in which the product is diluted or still in the form of cells. The solids are correspondingly separated by means of filtration, centrifugation or sedimentation. The cells are opened, for example, by mechanical force or osmotic pressure. Methods such as extraction, adsorption or precipitation are used for concentrating and purifying.

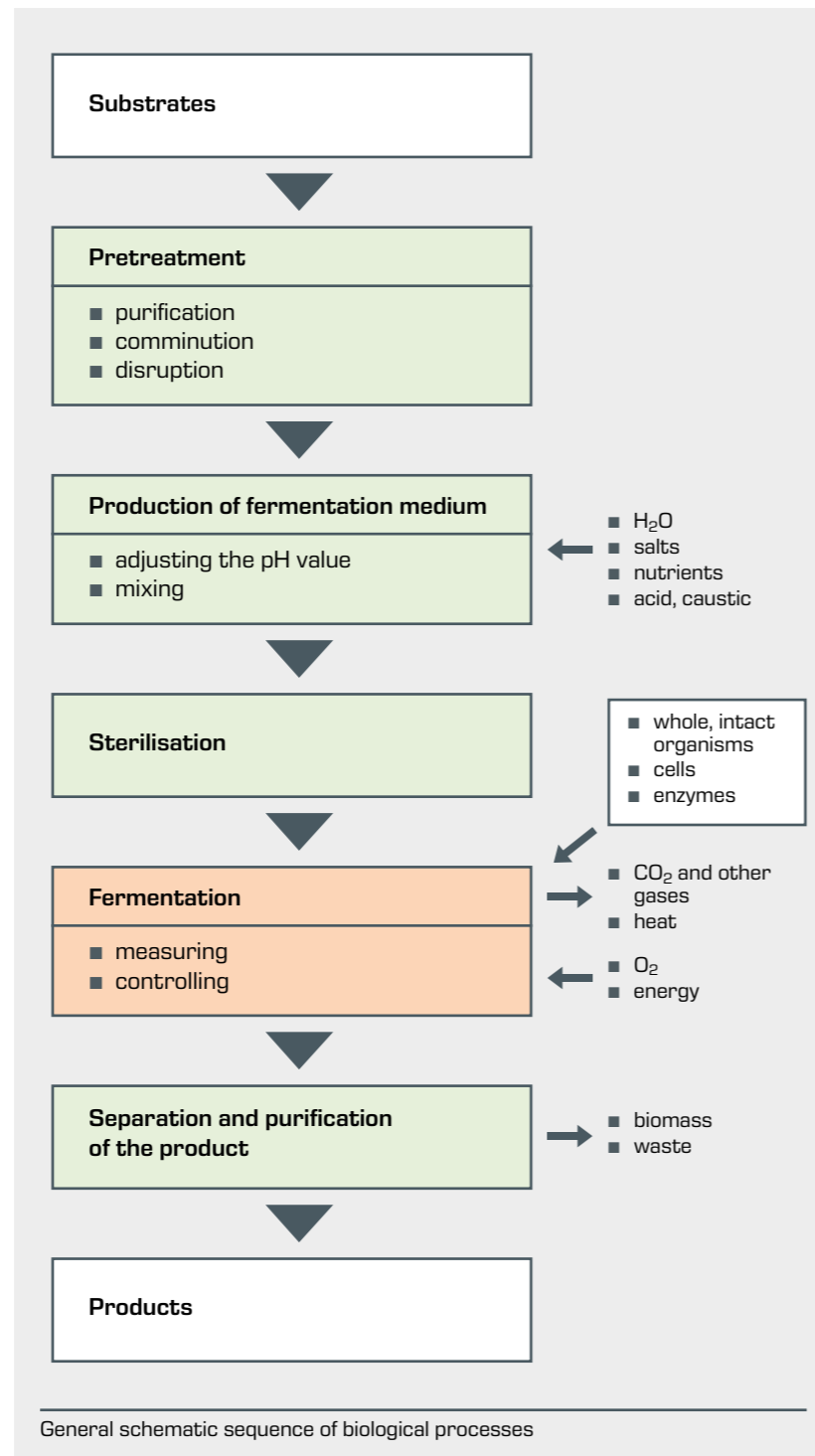

Bioreactors

The bioreactor is the core element of a biotechnical production facility. One of its main tasks is optimal mixing of the reactor contents to guarantee frequent contact of the nutrients and biological agents. In addition, it is important that the interface formed between the gaseous phase and the liquid is as large as possible. In aerobic processes, oxygen is transported to the biological agents. In anaerobic methods, the quick removal of gases such as methane must be ensured. A general distinction is made between surface reactors and submerged reactors.

Surface reactors

The biological agents adhere to the surface of liquid or solid substances as a biofilm. In aerobic processes, the oxygen comes directly from the gaseous phase bordering on the biofilm.

The simplest process is the **static surface culture (A)**. In this process, a biofilm floats on the surface of a liquid substrate in a shallow dish, where it is supplied with nutrients from below and oxygen from above.

In bed reactors, the biofilm is fixed on a solid surface. In fluidised bed reactors, the solid can move freely in the liquid. In **fixed bed reactors (B)**, the solid does not move. The liquid substrate trickles through the fixed bed from above. In aerobic reactors, the oxygen is supplied from below.

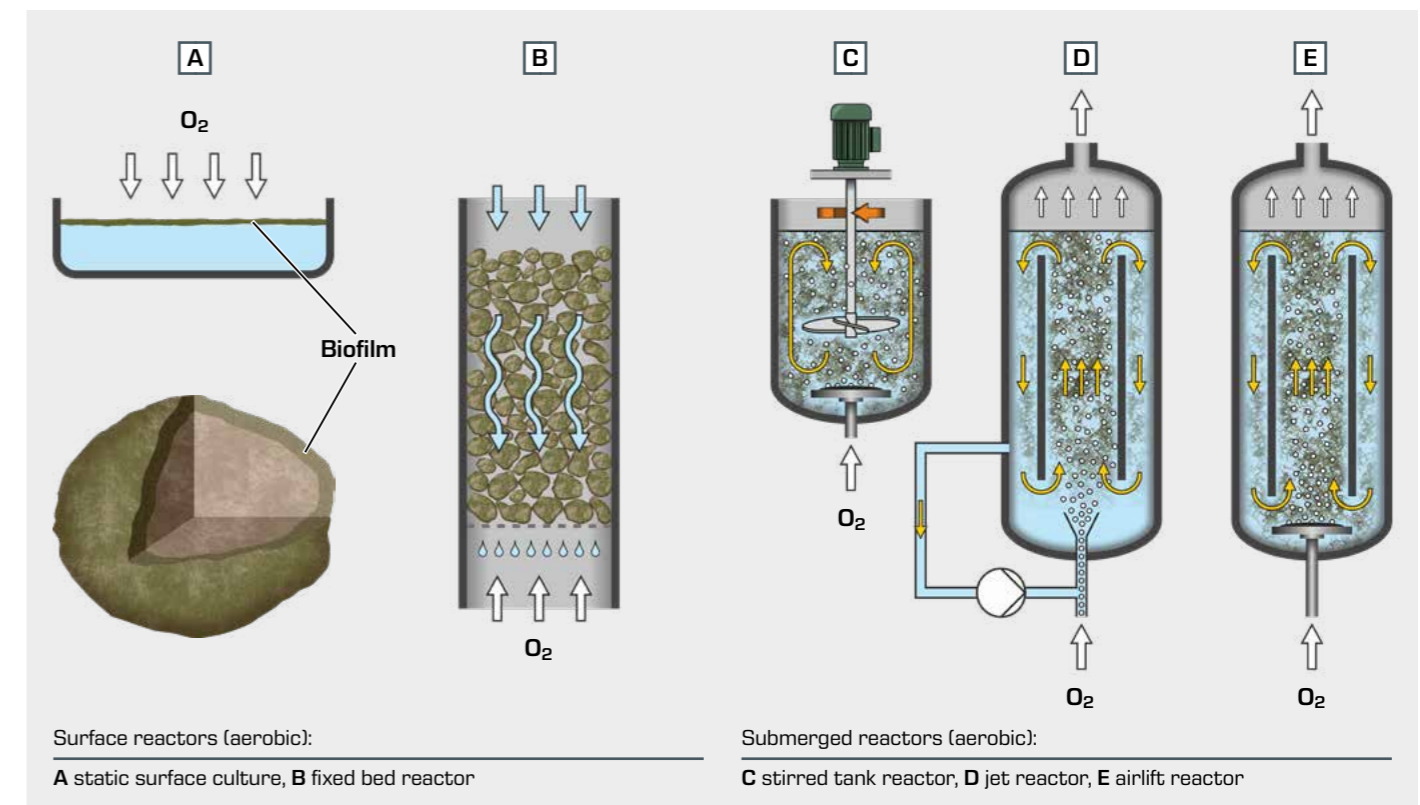

CE 701

Biofilm process



2E

The illustration shows: supply unit (left) and trainer (right)

Description

- aerobic biofilm processes: trickling filter
- practical experiments in laboratory scale
- concentration profiles

Fixed biofilm processes are used in the biological treatment of wastewater. Trickling filters are based on these processes.

A pump transports the wastewater from the supply unit to the upper end of the trickling filter. The wastewater drops down on the trickling filter using a rotary distributor. In the trickling filter there is a fixed bed consisting of special carrier material. On this carrier material there is a thin layer of microorganisms (biofilm). While the wastewater trickles through the fixed bed, the microorganisms clean the wastewater by biological processes. The degradation of organic substances preferably takes place in the upper region of the trickling filter. In the lower region on the other hand, the oxidation of ammonium to nitrate (nitrification) is the predominant process. Subsequently, the wastewater flows into a collecting tank. Two pumps deliver a portion of the collected wastewater to the rotary distributor again (recirculation).

In the lower region of the trickling filter there are openings to allow aeration by natural convection. Alternatively, aeration can take place with a compressor.

To produce the biofilm, the trickling filter is first filled with the carrier material, wastewater and activated sludge. The activated sludge continuously discharging from the trickling filter sediments into a secondary clarifier. A pump transports the activated sludge back to the trickling filter. The trickling filter is aerated by a compressor. Over time, microorganisms present in the activated sludge settle on the carrier material, thus producing the biofilm.

The following flow rates are recorded and can be adjusted: wastewater, recirculation, aeration (with compressor). The speed of the rotary distributor can also be adjusted. Sampling points on the trickling filter allow concentration profiles to be recorded.

Activated sludge from a wastewater treatment plant is required for the experiments. To analyse the experiments we recommend analytical equipment for determining the following parameters:

- biochemical or chemical oxygen demand
- ammonium concentration
- nitrate concentration

Learning objectives/experiments

- functional principle of a trickling filter
- recording of concentration profiles
- creation of a stable operating state
- identification of the following influencing factors
 - ▶ flow rate of recirculation
 - ▶ volumetric loading of the trickling filter
 - ▶ surface loading of the trickling filter
- comparison of various carrier materials

CE 701

Biofilm process

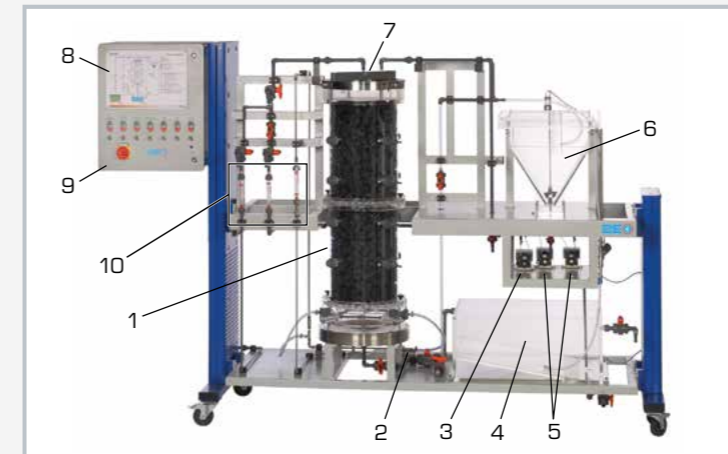

1 trickling filter, 2 compressor, 3 return sludge pump, 4 collecting tank, 5 circulation pumps, 6 secondary clarifier, 7 rotary distributor, 8 process schematic, 9 switch cabinet, 10 flow meter

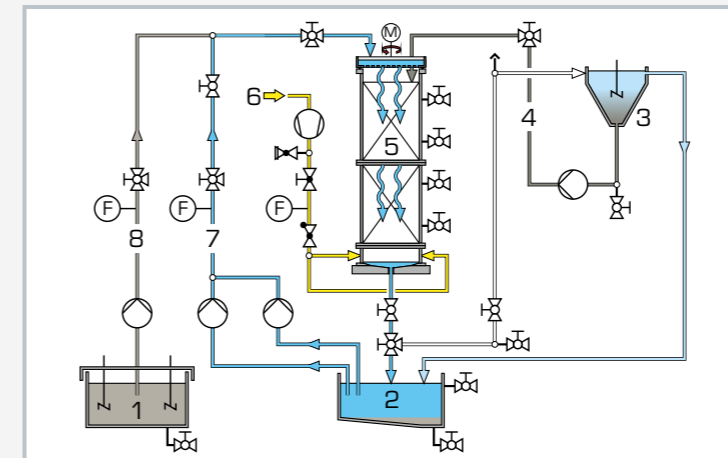

1 wastewater tank, 2 collecting tank, 3 secondary clarifier, 4 return sludge, 5 trickling filter, 6 air, 7 recirculation, 8 wastewater; F flow rate

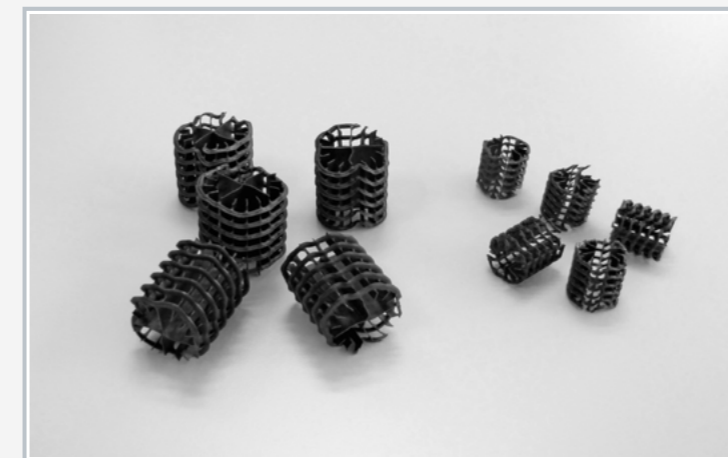

carrier material for biofilm

Specification

- [1] aerobic biofilm process for the degradation of organic substances and for nitrification
- [2] transparent trickling filter with rotary distributor
- [3] speed of the rotary distributor finely adjustable
- [4] aeration of the trickling filter by natural convection or with compressor
- [5] recording of concentration profiles is possible
- [6] secondary clarifier with pump for transporting the return sludge
- [7] all relevant flow rates finely adjustable
- [8] separate supply unit with wastewater tank and two stirring machines
- [9] two different carrier materials made of HDPE

Technical data

Trickling filter

- diameter: approx. 340mm
- height: approx. 1000mm
- capacity: approx. 90L

Rotary distributor

- max. speed: approx. 2min⁻¹

Tanks

- wastewater tank: 300L
- collecting tank: 90L
- secondary clarifier: 30L

Flow rates

- wastewater pump: max. 25L/h
- circulation pumps: 2x max. 25L/h
- return sludge pump: max. 25L/h
- compressor: max. 600L/h

Carrier material

- specific surface: 180 or 300m²/m³

Measuring ranges

- flow rate:
 - ▶ 2...25L/h (wastewater)
 - ▶ 5...65L/h (recirculation)
 - ▶ 50...900L/h (aeration)

230V, 50Hz, 1 phase

230V, 60Hz, 1 phase

120V, 60Hz, 1 phase

UL/CSA optional

LxWxH: 1550x790x1150mm (supply unit)

LxWxH: 2870x790x1900mm (trainer)

Total weight: approx. 500kg

Required for operation

water connection, drain, activated sludge, substances for preparation of artificial wastewater

Scope of delivery

- 1 trainer
- 1 supply unit
- 1 set of hoses
- 1 set of tools
- 2 packing units of carrier material
- 1 set of instructional material

CE 704 SBR process



2E

Description

- biological wastewater treatment
- Sequencing Batch Reactor (SBR)
- process controller with touch screen

The SBR process is a biological, aerobic wastewater treatment process. In contrast to the classic activated sludge process, the individual process steps are not continuous and do not take place simultaneously, but rather are carried out in batches and sequentially in one single reactor.

The reactor is equipped with a compressor for aeration and a stirring machine. The stirring machine ensures sufficient mixing of the reactor contents even in phases without aeration (denitrification). At the end, the treated water (clear water) is extracted from the reactor and collected in a tank. This is done with a floating device, as is typical for the SBR process. Above the reactor is a device for metering an external carbon source (e.g. sugar solution) if required.

Timers for the compressor and stirring machine make it possible to set the aeration phases (nitrification) and mixing phases (denitrification) individually.

The oxygen concentration, pH value and temperature in the reactor are measured. A digital process controller continuously displays the measured values and the speed of the stirring machine. The process controller has a touch screen and also functions as a controller for the oxygen concentration during the aeration phases.

Activated sludge (e.g. from a wastewater treatment plant) is required for the experiments. Table sugar (sucrose) can be used as a carbon source for the synthetic wastewater. The following parameters must be determined in order to analyse the experiments:

- total organic matter
 - BOD₅ or COD or TOC
- nitrogen concentrations
 - NH₄-N: ammonium
 - NO₂-N: nitrite
 - NO₃-N: nitrate

Learning objectives/experiments

- how the SBR process works
- elimination of nitrogen by nitrification and denitrification
- influence of cycle design on treatment results
- recording and interpretation of chronological concentration patterns
- determining conversion rates
- sedimentation properties of activated sludge

CE 704 SBR process



1 control elements for the compressor and for the stirring machine, 2 process controller, 3 flow meter (air), 4 pH value sensor, 5 metering device, 6 stirring machine, 7 oxygen sensor, 8 aeration device, 9 float for clear water extraction, 10 suction bulb for clear water



Digital process controller
display of process variables (left), user interface for controlling oxygen concentration (right)

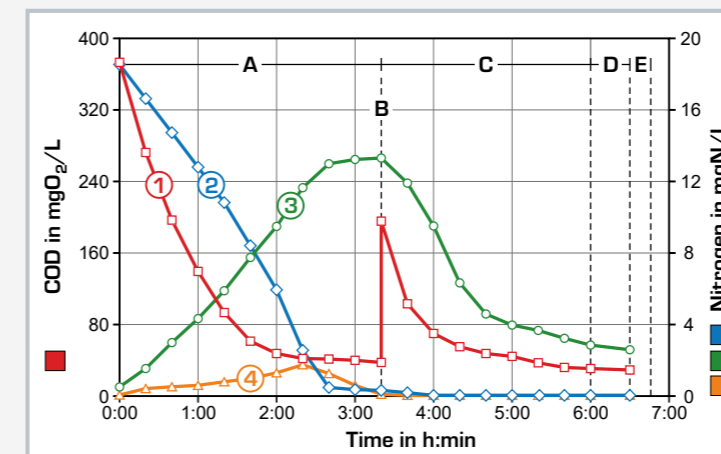

Measured concentration patterns
1 chemical oxygen demand (COD), 2 ammonium (NH₄-N), 3 nitrate (NO₃-N), 4 nitrite (NO₂-N)

Process steps

A mix with aeration (nitrification), B metering a sugar solution (external carbon source), C mix without aeration (denitrification), D sedimentation of the activated sludge, E extraction of the treated water (clear water)

Specification

- [1] discontinuous activated sludge process
- [2] Sequencing Batch Reactor (SBR)
- [3] stirring machine with timer and continuously adjustable speed
- [4] compressor with timer for aeration
- [5] floating device for extraction of the treated water
- [6] metering device for external carbon source
- [7] flow meter for aeration
- [8] tanks for wastewater and treated water
- [9] measurement of pH value, temperature and oxygen concentration
- [10] process controller with touchscreen for displaying process variables and for controlling the oxygen concentration

Technical data

Reactor

- Ø 290mm
- height: 300mm
- max. capacity: 18L
- material: plexiglass

Tanks

- wastewater: 15L
- treated water: 30L
- metering vessel: 260 mL

Stirring machine: max. 330min⁻¹

Compressor: max. 15,5L/min

Measuring ranges

- oxygen concentration: 0...20mg/L
- pH value: 0...14
- temperature: 0...50°C
- flow rate: 50...900L/h

230V, 50Hz, 1 phase
230V, 60Hz, 1 phase; 120V, 60Hz, 1 phase
UL/CSA optional
LxWxH: 850x520x480mm
Weight: approx. 30kg

Required for operation

aerobic activated sludge, sugar, analysis technology

Scope of delivery

- 1 experimental unit
- 3 packing units of pH calibration solution (1L each)
- 1 packing unit of potassium chloride solution (1L)
- 1 packing unit of ammonium hydrogen carbonate (250g)
- 1 packing unit of dipotassium hydrogen phosphate (250g)
- 1 set of accessories
- 1 set of instructional material

Overview

CE 705 Activated sludge process



A laboratory-scale wastewater treatment plant

The aerobic activated sludge process is the most widely-used biological process in wastewater treatment plants worldwide. Sound knowledge of this process is therefore essential for budding engineers and specialist technicians in the field of environmental engineering.

This device has been designed by experienced engineers with the aim of being able to clearly teach the complex processes involved in this process in continuous operation in a practical manner. The device is designed for carbon elimination and nitrogen elimination. The nitrogen is removed by nitrification and pre-denitrification. To this end, the aeration tank is divided into an aerobic and an anoxic area.

Operation with PLC

The control of the trainer is realised by the integrated PLC via touch screen. By means of an integrated router, the trainer can alternatively be operated and controlled via an end device. The user interface can also be displayed on additional end devices (screen mirroring). The measured values are displayed on the touch screen and can simultaneously be viewed directly on a PC or mobile end device via LAN.

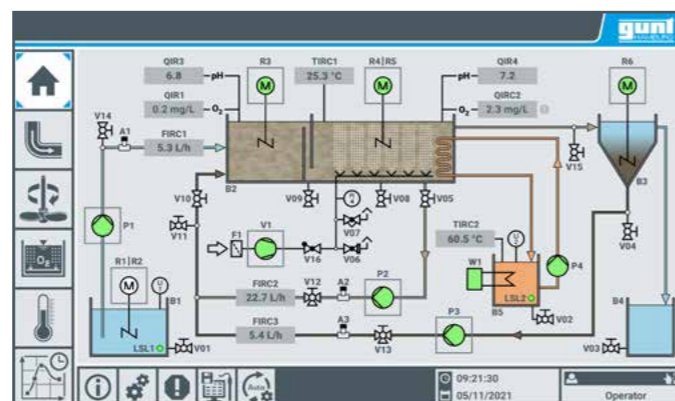

User interface of the touch screen (overview)

Learning objectives

- functional principle of nitrification and pre-denitrification
- creation of a stable operating state
- identification of the following influencing factors
 - ▶ sludge age
 - ▶ volumetric loading
 - ▶ sludge loading
 - ▶ return sludge ratio
 - ▶ return ratio of the internal recirculation (denitrification)
- efficiency of the pre-denitrification
- influence of the following ambient conditions to the biological degradation
 - ▶ temperature
 - ▶ oxygen concentration

Instrumentation and control technology

Nowadays, complex processes such as the activated sludge process are largely automated. The use of modern instrumentation and control technology is indispensable for this purpose. This also requires that engineers in the field of environmental engineering have at least basic knowledge of such systems.

To prepare students for the challenges of professional practice, we have also observed this important aspect when developing the device. CE 705 is therefore equipped with extensive instrumentation for measurements and a PLC with touch screen.

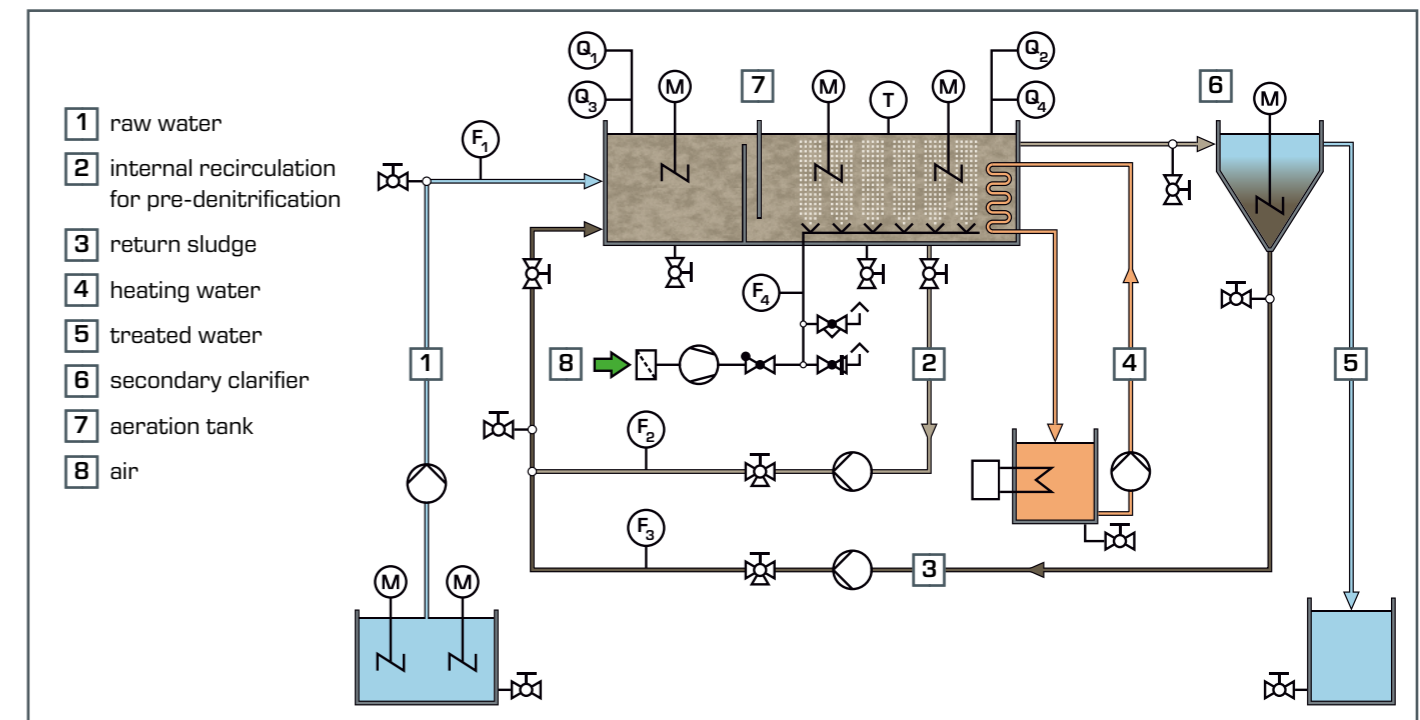

Measured variables

			Auto
flow rate	F ₁	raw water	<input checked="" type="checkbox"/>
	F ₂	internal recirculation	<input checked="" type="checkbox"/>
	F ₃	return sludge	<input checked="" type="checkbox"/>
	F ₄	aeration	<input type="checkbox"/>
oxygen concentration	Q ₁	denitrification area	<input type="checkbox"/>
	Q ₂	nitrification area	<input checked="" type="checkbox"/>
pH value	Q ₃	denitrification area	<input type="checkbox"/>
	Q ₄	nitrification area	<input type="checkbox"/>
temperature	T	nitrification area	<input checked="" type="checkbox"/>

About the product:



Auto control

CE 705

Activated sludge process



The illustration shows: trainer (left) and supply unit (right), screen mirroring is possible on different end devices

Description

- aerobic biological degradation of organic substances
- nitrification and pre-denitrification
- device control using an integrated PLC
- integrated router for operation and control via an end device and for screen mirroring on additional end devices: PC, tablet, smartphone

The activated sludge process is the most important biological process in water treatment. CE 705 enables this process to be demonstrated.

A pump delivers raw water contaminated with dissolved organic substances (organic matter) into the aeration tank. Aerobic microorganisms (activated sludge) in the aeration tank use the organic matter as a source of nutrition, biodegrading it in the process. Since aerobic microorganisms need oxygen, the raw water is aerated in the aeration tank. The activated sludge is mixed with the raw water by stirring machines. In the secondary clarifier the activated sludge is then separated from the treated water by sedimentation. A portion of the activated sludge is returned to the aeration tank (return sludge). The treated water is collected in a tank.

It is also possible to convert ammonium into nitrate (nitrification) and nitrate into nitrogen (denitrification). For denitrification a zone without aeration can be created in the aeration tank by installing a partition wall.

The control of the trainer is realised by the integrated PLC via touch screen. By means of an integrated router, the trainer can alternatively be operated and controlled via an end device. The user interface can also be displayed on additional end devices (screen mirroring). Via the PLC, the measured values can be stored internally. Access to stored measured values is possible from end devices via WLAN with integrated router/ LAN connection to the customer's own network.

Activated sludge from a wastewater treatment plant and analysis technology are required for the experiments. The following parameters must be determined in order to analyse the experiments:

- organic matter
BOD₅ or COD or TOC
- nitrogen concentrations
ammonium, nitrite and nitrate

Learning objectives/experiments

- learning the fundamental principle of the activated sludge process
- functional principle of nitrification and pre-denitrification
- creation of a stable operating state
- identification of the following influencing factors
 - ▶ return sludge ratio
 - ▶ reflux ratio of the internal recirculation
 - ▶ sludge age
 - ▶ sludge loading
 - ▶ volumetric loading
 - ▶ oxygen concentration and temperature
- efficiency of the pre-denitrification
- screen mirroring: mirroring of the user interface on end devices
 - ▶ menu navigation independent of the user interface shown on the touch screen
 - ▶ different user levels available on the end device: for observing the experiments or for operation and control

CE 705

Activated sludge process

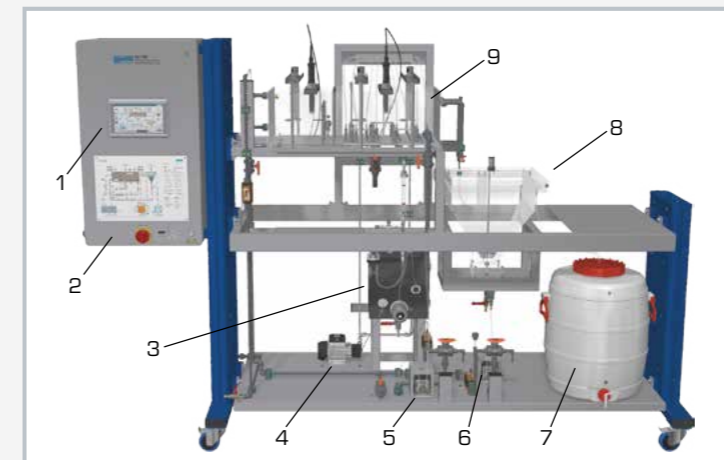

1 PLC with touch screen, 2 switch cabinet, 3 heating water tank, 4 heating water pump, 5 circulation pump, 6 return sludge pump, 7 treated water tank, 8 secondary clarifier, 9 aeration tank

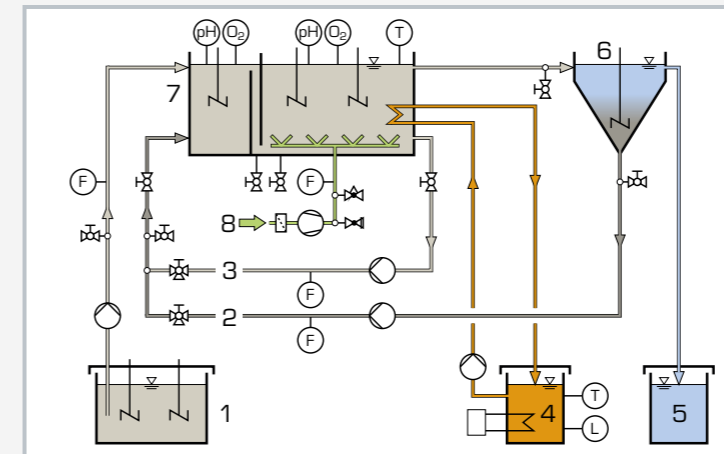

1 raw water, 2 return sludge, 3 internal recirculation for pre-denitrification, 4 heating water, 5 treated water, 6 secondary clarifier, 7 aeration tank, 8 air, F flow rate, L level, O₂ oxygen concentration, T temperature

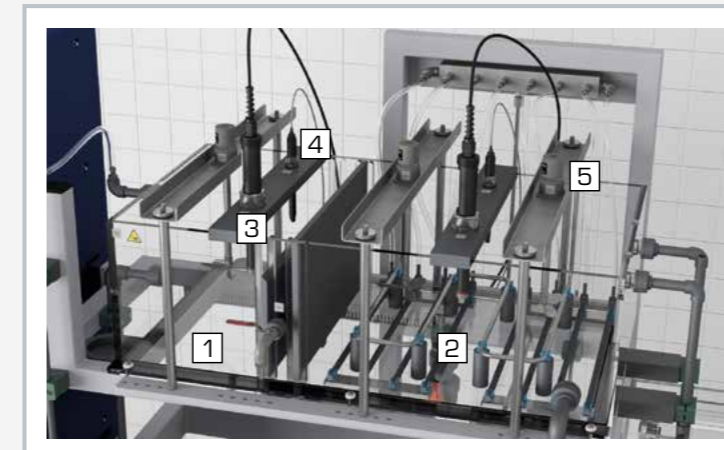

Aeration tank:
1 denitrification zone (non-aerated), 2 nitrification zone (aerated), 3 oxygen sensor, 4 pH value sensor, 5 stirring machine

Specification

- [1] aeration tank divided into two areas
- [2] secondary clarifier with sludge scraper
- [3] nitrification and pre-denitrification
- [4] separate supply unit with 2 stirring machines
- [5] control and measurement of temperature, oxygen concentration and flow rate
- [6] measurement of pH value in the aeration tank
- [7] electromagnetic flow rate sensors
- [8] device control with PLC via touch screen
- [9] integrated router for operation and control via an end device and for screen mirroring: mirroring of the user interface on up to 5 end devices
- [10] data acquisition via PLC on internal memory, access to stored measured values via WLAN with integrated router/ LAN connection to customer's own network

Technical data

PLC: Eaton XV-303

Tanks

- aeration tank (nitrification zone): approx. 34L
- aeration tank (denitrification zone): approx. 17L
- secondary clarifier: 30L
- raw water tank: 200L
- treated water tank: 80L

Flow rates

- raw water pump: max. 34L/h
 - return sludge pump: max. 34L/h
 - circulation pump: max. 34L/h
- Speeds (stirring machines)
- raw water tank: each max. 600min⁻¹
 - aeration tank: each max. 330min⁻¹
 - secondary clarifier: max. 45min⁻¹

Measuring ranges

- flow rate:
 - ▶ 0,6...30L/h (raw water and return sludge)
 - ▶ 3...60L/h (internal recirculation)
 - ▶ 50...550L/h (compressed air)
- temperature: 0...50°C
- pH value: 0...14
- oxygen concentration: 0...20mg/L

230V, 50Hz, 1 phase

230V, 60Hz, 1 phase; 120V, 60Hz, 1 phase

UL/CSA optional

LxWxH: 1550x790x1150mm (supply unit)

LxWxH: 2830x790x1900mm (trainer)

Total weight: approx. 450kg

Required for operation

water connection, drain, activated sludge, analysis technology

Scope of delivery

trainer, supply unit, pH calibration solutions, potassium chloride solution, dipotassium hydrogen phosphate, ammonium hydrogen carbonate, instructional material

Overview

CE 730 Airlift reactor

Powerful bioreactors

Supplying the microorganisms (biomass) with oxygen is of crucial importance for the performance of an aerobic bioreactor. Another important aspect is uniform mixing of the reactor contents. Airlift reactors meet both of these challenges to a particular degree.

In an airlift reactor mixing occurs exclusively through the aeration, which is necessary anyway. Mechanically moving parts (e.g. stirring machines) are not necessary. The retention of the biomass in the reactor required for effective operation is achieved by circulation. Airlift reactors are used in biotechnology and in biological wastewater treatment.

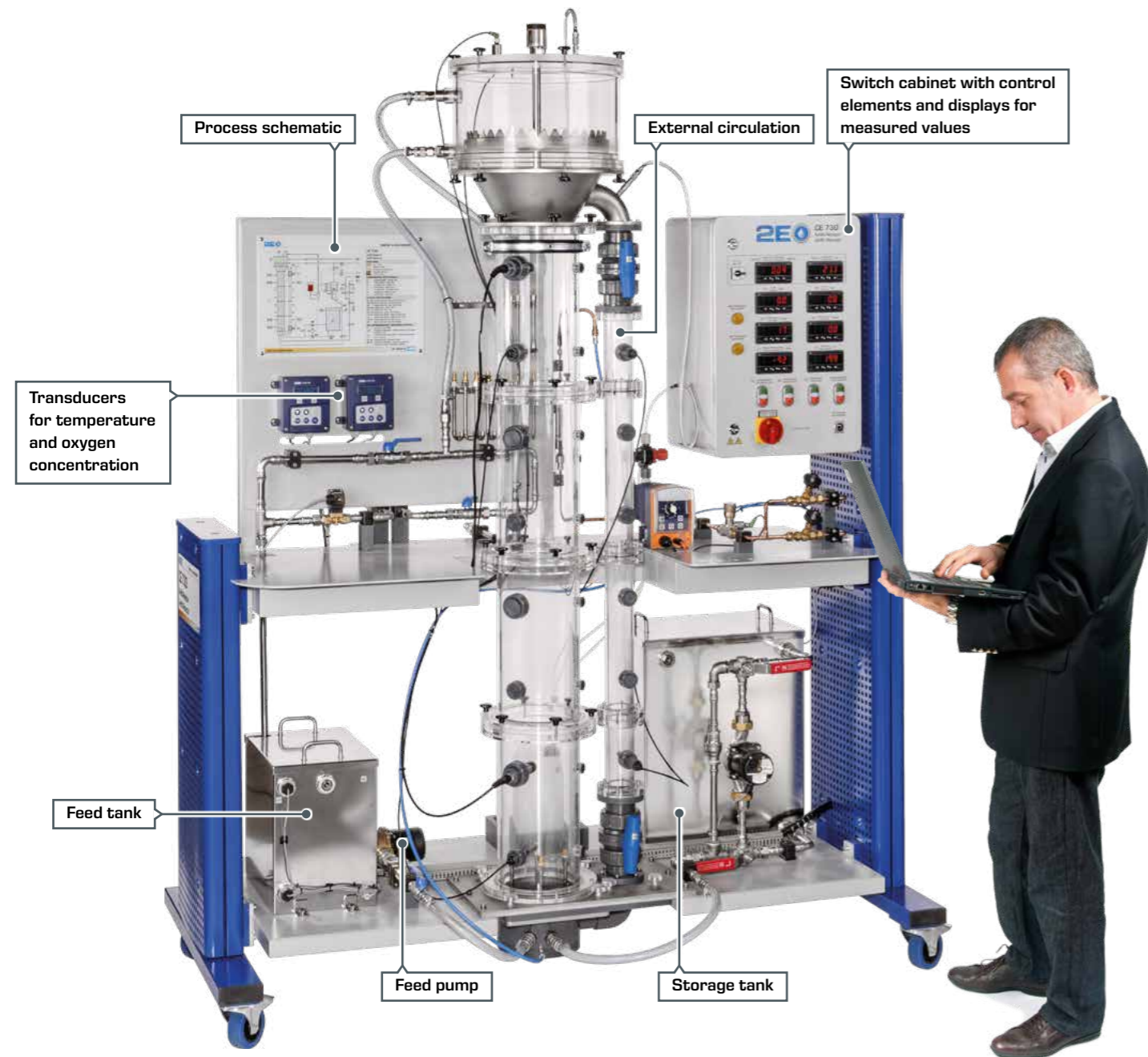

Airlift reactor CE 730

The educational focus is the functional principle and operation of an airlift reactor. These mainly include releasing oxygen in the liquid phase (water) and determining the flow conditions in the reactor.

The core of the trainer is an airlift reactor with external circulation. There are several different distributors available for aeration of the reactor. This allows you to study how bubble size influences mass transfer. Two measuring points for conductivity are located on the circulation at defined intervals. Adding a salt solution causes a sharp increase (peak) in conductivity at both measurement points, with some delay between them. The time difference between the two peaks and the distance between the measuring points can be used to determine the flow velocity in the reactor.



Airlift reactor during a test run

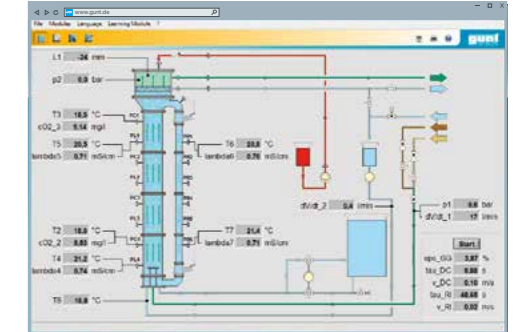

Software

The clearly-arranged software included with CE 730 continuously displays all key process variables. You can of course save the measured values for analysis.



Various distributors for aerating the reactor

Learning objectives

- influence of the superficial gas velocity on:
 - ▶ gas content
 - ▶ mass transfer coefficient
 - ▶ mixing time
 - ▶ superficial fluid velocity

About the product:



CE 730

Airlift reactor



Learning objectives/experiments

- influence of the superficial gas velocity on:
 - ▶ gas content
 - ▶ mass transfer coefficient
 - ▶ mixing time
 - ▶ superficial fluid velocity

Description

- aerobic submerged reactor
- external circulation
- investigation of characteristic properties

Airlift reactors are submerged reactors in which the energy input is achieved by applying gas. Compressed air is often used as the gas.

During operation compressed air enters the airlift reactor at the bottom through the gas distributor. The added air mixes with the contents of the reactor and rises in the form of air bubbles. The rising air bubbles cause an upward flow. In doing so a portion of the oxygen in the air dissolves in the water. The area with the upward flow is called the riser. The remaining air bubbles leave the water at the top of the reactor. The gas-free liquid is fed back to the bottom section of the reactor in parallel to the riser.

The area with the downward flow of an airlift reactor is called the downcomer. During operation the content of the reactor is recirculated through the riser and the downcomer. This recirculation is overlaid by perfusion in continuous operation. An additional tank with feed pump is provided for this purpose. The velocity of the circulation is set by the flow rate of the air.

The CE 730 trainer is designed for the study of characteristic properties of an airlift reactor with air, nitrogen and water. Applying air causes the oxygen content in the water to increase. It is possible to reduce the oxygen content in the water by using nitrogen. This is the prerequisite for determining the mass transfer coefficient of oxygen in water.

The liquid superficial velocity is determined by measuring the electrical conductivity. A metering pump and a tank for a salt solution are provided to increase the electrical conductivity. The mixing time is determined by an indicator. The gas content is determined by the level in the airlift reactor.

The measured values are displayed digitally on the switch cabinet and can simultaneously be transmitted via USB directly to a PC, where they can be analysed using the software included.

CE 730

Airlift reactor



1 airlift reactor with external circulation, 2 feed pump, 3 feed tank, 4 circulating pump, 5 storage tank, 6 metering pump

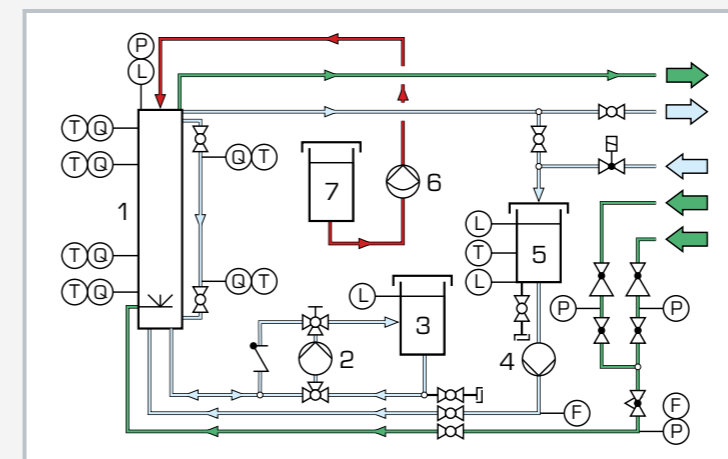

1 airlift reactor with external circulation, 2 circulating pump, 3 storage tank, 4 feed pump, 5 feed tank, 6 metering pump, 7 tracer tank; F flow rate, L level, P pressure, Q analysis, T temperature; blue: water, green: gas, red: tracer

Specification

- [1] determination of important characteristic variables at the airlift reactor
- [2] transparent airlift reactor with external recirculation
- [3] compressed air for generation of air bubbles to recirculate the reactor contents
- [4] adjustment of the superficial gas velocity via a valve and mass flow controller
- [5] nitrogen to remove the oxygen from the reactor content
- [6] determination of the superficial liquid velocity via the conductivity
- [7] determination of the mixing time with indicator and colour change method
- [8] sensors for measuring the conductivity, oxygen content, pressure and flow rate
- [9] GUNT software for data acquisition via USB under Windows

Technical data

Airlift reactor

- riser: Ø 180mm
- downcomer: Ø 60mm
- height: 2000mm

Measuring ranges

- conductivity: 4x 0...100mS/cm
- oxygen concentration: 2x 0...10mg/L
- pressure: 0...3bar
- flow rate:
 - ▶ 0,06...3m³/h (water)
 - ▶ 1...10m³/h (gas)

230V, 50Hz, 1 phase
230V, 60Hz, 1 phase; 120V, 60Hz, 1 phase
UL/CSA optional
LxWxH: 1850x790x2450mm
Weight: approx. 300kg

Required for operation

compressed air (>8m³/h), nitrogen gas cylinder with pressure reducing valve, cold water connection (>400L/h), drain
PC with Windows recommended

Scope of delivery

- 1 trainer
- 1 GUNT software + USB cable
- 1 set of accessories
- 1 set of instructional material

Overview CE 702 Anaerobic water treatment

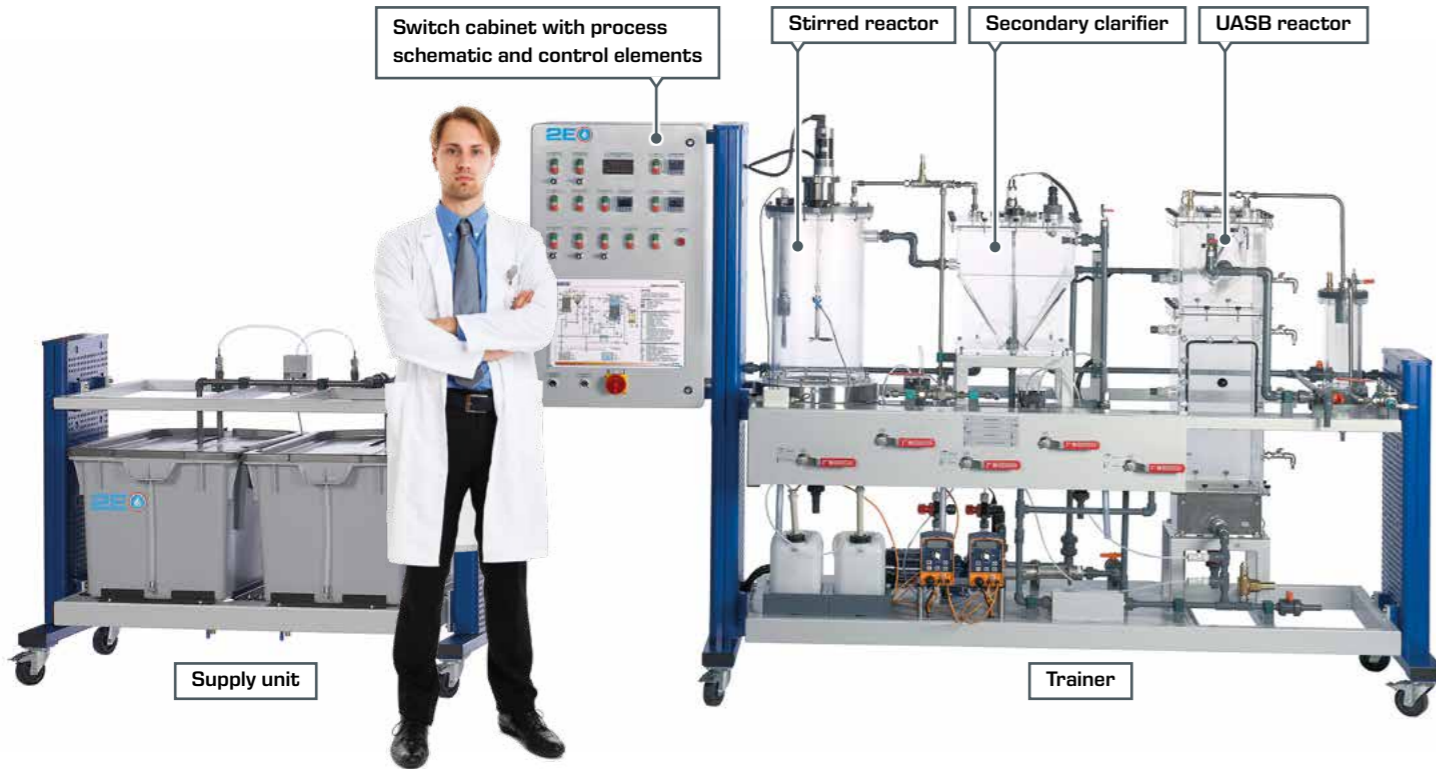

Anaerobic processes are primarily used for wastewater which is highly contaminated with organic substances, such as those occurring in the food industry.

Our CE 702 teaching unit offers you two different methods. These are the anaerobic activated sludge process and the UASB process. You can operate both processes separately (1-stage) or in series (2-stage). This gives you a total of three different modes of operation. The device is also equipped with extensive instrumentation and control technology and software.

You also receive comprehensive instructional material on this device that quickly helps you become familiar with operation of the device. In addition, the theoretical fundamentals of anaerobic wastewater treatment are clearly represented in detail.

The 2-stage operating mode allows you to control the pH and the temperature independently of each other in both stages. This type of process control has proven itself in practice and has the advantage of being able to better adapt the environmental conditions to the needs of each of the degradation steps. The device is equipped with gas collecting pipes, which can be used to take gas samples from the system for analysis.

Operating mode 1 (1-stage)	
Operating mode 2 (1-stage)	
Operating mode 3 (2-stage)	

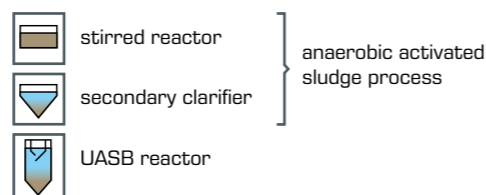

CE 702's UASB reactor during a successful trial run in our laboratory

Software

The software included with CE 702 shows the temperatures and pH values in both reactors continuously. This gives you a quick overview of the conditions in the reactors at any time. You can save the measured values for analysis. This relieves you of routine work and thus aids you when conducting the experiments.

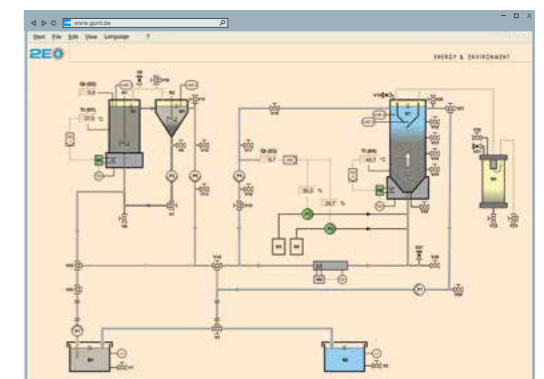

Process schematic with display of the measured values

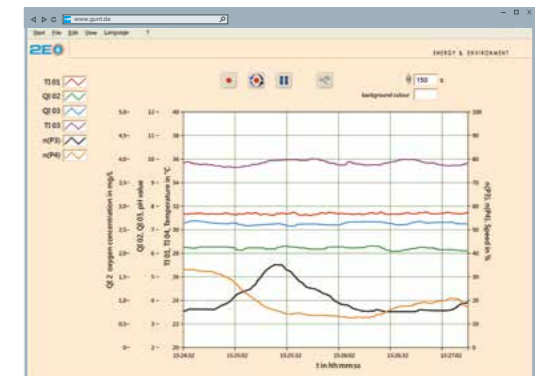

Display of the measured values as time dependency

Learning objectives

- effects of temperature and pH value on anaerobic degradation
- functional principle of a UASB reactor
- comparison of single stage and dual stage operation mode
- monitoring and optimisation of the operating conditions
- identification of the following influencing factors
 - ▶ sludge loading
 - ▶ volumetric loading
 - ▶ flow velocity in the UASB reactor

About the product:



CE 702

Anaerobic water treatment



The illustration shows: supply unit (left) and trainer (right)

Description

- anaerobic degradation of organic substances in the stirred tank and UASB reactor
- three different operation modes

CE 702 demonstrates the biological anaerobic water treatment. The trainer consists basically of two units:

- stirring tank with secondary clarifier
- UASB reactor

Both units can be used separately or in combination. This allows both a single stage and a dual stage operation mode. In the dual stage operation a pump first transports the raw water into a stirred tank. In this tank the acidification of the organic substances dissolved in the raw water takes place. Here, anaerobic microorganisms convert the long-chain organic substances into short-chain organic substances. In a secondary clarifier the biomass discharged from the stirred tank is separated from the water. The separated biomass is pumped back into the stirring tank.

From the secondary clarifier the raw water pretreated in this manner reaches a UASB reactor (UASB: Upflow Anaerobic Sludge Blanket). Here the final step of the anaerobic degradation takes place.

The previously formed short-chain substances are converted by special microorganisms into biogas (methane and carbon dioxide). Flow through the UASB reactor is from the bottom to the top. At the top of the UASB reactor there is a separation system. This separates the generated gas from the treated water. It also ensures that the biomass remains in the reactor. The gas can be discharged externally or collected. The treated water exits at the top end of the reactor and is collected in a tank.

To adjust the flow velocity in the UASB reactor a of the treated water can be recirculated.

The temperatures in the stirred tank and the UASB reactor can be controlled. The pH value in the stirred tank is measured. In addition, the pH value in the UASB reactor can be controlled. A software and webcam are available for data acquisition and visual inspection.

Anaerobic biomass and analysis technology are required to perform the experiments. Recommended parameters are: COD (chemical oxygen demand), nitrogen and phosphor.

Learning objectives/experiments

- familiarisation with anaerobic water treatment
- effects of temperature and pH value on anaerobic degradation
- functional principle of a UASB reactor
- comparison of single stage and dual stage operation mode
- monitoring and optimisation of the operating conditions
- identification of the following influencing factors
 - ▶ sludge loading
 - ▶ volumetric loading
 - ▶ flow velocity in the UASB reactor

CE 702

Anaerobic water treatment

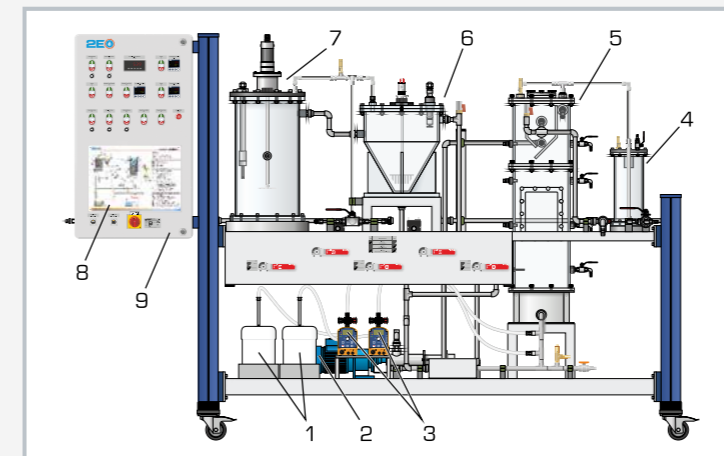

1 chemical tanks, 2 circulation pump, 3 metering pumps, 4 foam separator, 5 UASB reactor, 6 secondary clarifier, 7 stirred tank, 8 process schematic, 9 switch cabinet

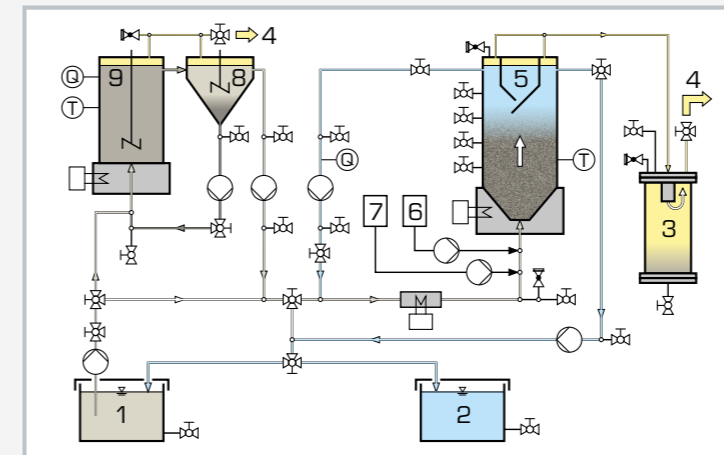

1 raw water, 2 treated water, 3 foam separator, 4 gas, 5 UASB reactor, 6 acid, 7 caustic, 8 secondary clarifier, 9 stirred tank; T temperature, Q pH value



UASB reactor during experimental operation

Specification

- [1] anaerobic degradation of organic substances
- [2] stirred tank with secondary clarifier
- [3] UASB reactor with separation system
- [4] separate supply unit with tanks for raw water and treated water
- [5] single stage or dual stage operation mode
- [6] temperatures in the stirred tank and the UASB reactor can be controlled
- [7] control of the pH value in the UASB reactor
- [8] GUNT software for data acquisition via USB under Windows 8.1, 10
- [9] visual inspection with webcam

Technical data

Tanks

- stirred tank: 30L
- secondary clarifier: 30L
- UASB reactor: 50L
- tank for raw water: 180L
- tank for treated water: 180L

Flow rates (max.)

- raw water pump: 10L/h
- return sludge pump: 10L/h
- circulation pump: 100L/h
- metering pumps: 2x 2,1L/h

Measuring ranges

- pH value: 0...14
- temperature: 0...100°C

400V, 50Hz, 3 phases
400V, 60Hz, 3 phases
230V, 60Hz, 3 phases
UL/CSA optional
LxWxH: 1550x790x1150mm (supply unit)
LxWxH: 2830x790x1900mm (trainer)
Total weight: approx. 520kg

Required for operation

water connection, drain, sewage sludge, pellets from an UASB reactor, substances for preparation of artificial wastewater, caustic soda, hydrochloric acid, pH calibration solutions, potassium chloride solution
PC with Windows recommended

Scope of delivery

- 1 trainer
- 1 supply unit
- 1 set of accessories
- 1 GUNT software + USB cable
- 1 set of instructional material

Basic knowledge Bioethanol

The consumption of fossil fuels (coal, petroleum, natural gas) has risen sharply in recent decades. The outputs required to cover the energy demand are leading to an ever more rapid depletion of deposits. Newly discovered deposits are difficult to extract due to the location and frequent impurities. Therefore alternatives are being sought.

Replenishable biomass can be used to produce storable carbon neutral energy sources. These energy sources play an important role alongside discontinuous sources such as solar and wind in realising a carbon neutral and renewable energy supply.

Different biological and thermal processes are used to convert the biogenic energy feedstock into a storable energy source.



The CO₂ cycle of bioethanol

Photosynthesis, by means of sunlight, enables plant growth. In this process, CO₂ from the atmosphere, as well as water and inorganic substances from the plants are absorbed and converted into energy-rich organic compounds. This biomass can be regarded as the product of a biochemical process, in which a portion of the absorbed sunlight is stored in the form of chemical energy. Being able to use the biomass as an energy source in various technical processes requires special treatment processes. These include simple physical processes as well as more complex thermochemical and biological processes.

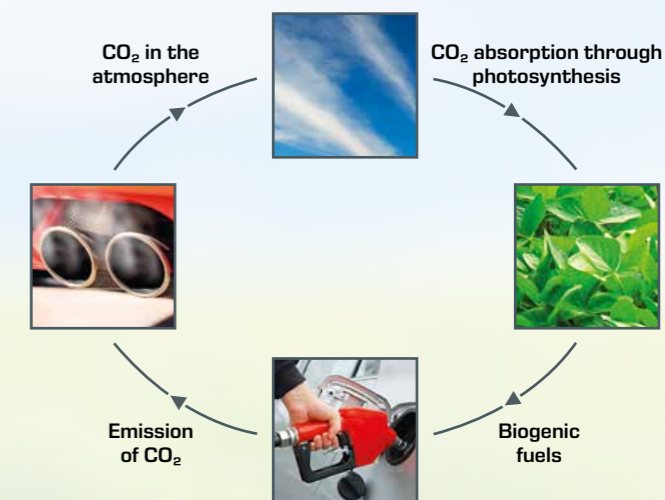

Biofuels for carbon neutral energy

In addition to the simple mechanical processes such as comminution and press agglomeration used to produce solid energy sources (pellets), complex biological processes are used to produce biofuels and biogas.

These methods are applications of natural processes on an industrial scale. Factors such as temperature, pH value, mixing and retention time play an important role in these processes, so as to achieve the greatest yield of energy sources from the biomass.

Biofuels are substitutes for super unleaded and diesel fuels, which are either mixed with fossil fuels or used directly with appropriate engine technology. The basis of biofuel is ethanol for super unleaded fuel and vegetable oil for diesel fuel.

For the field of biofuels, we supply both a complete system that uses enzymes and yeasts to convert starch ethanol, and another system for the conventional production of biodiesel from vegetable oils by means of transesterification.

In addition to the distillation unit for the separation of ethanol from the digestate, our bioethanol plant also contains the previously required mash and fermentation tanks for the complete production process.

Starting materials for bioethanol are the carbohydrates (sugars) contained in the plants, from which alcohol is created with the aid of enzymes and yeast fungus. While plants containing sugar are fermented directly, in the case of starchy plants it is the actual alcoholic fermentation of the enzymatic digestion of the plant material that comes first.

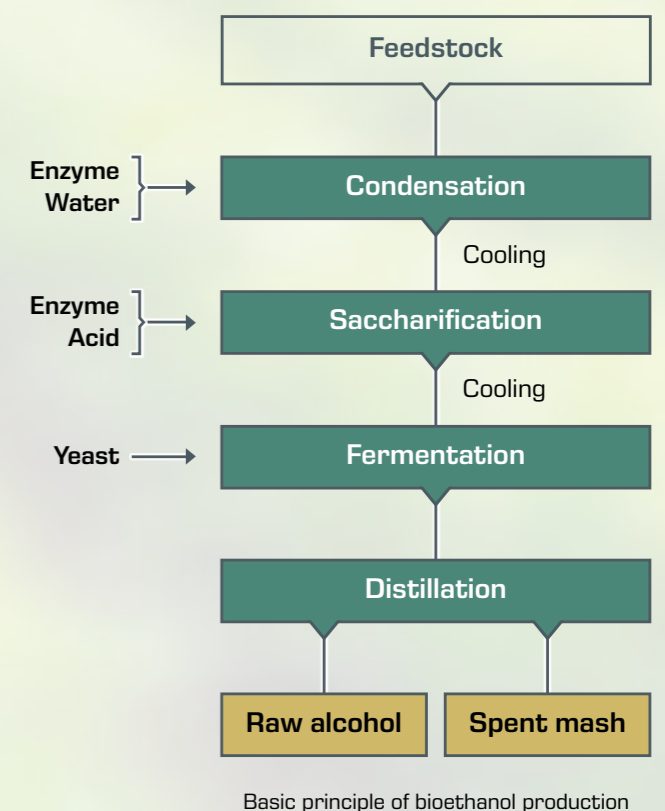

The fermentation process is completed once either the sugar is consumed or a maximum alcohol concentration is reached. The resulting bioethanol is separated by distillation. The product of distillation is called raw alcohol.

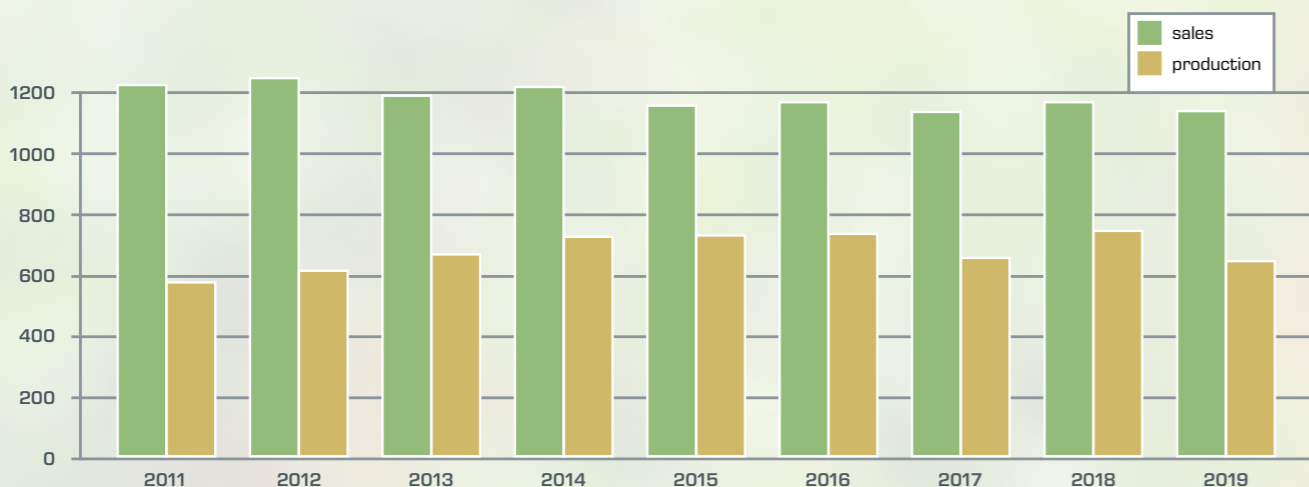

Growth of bioethanol in Germany (in 1000t)

(source: BDBe/FNR)

Overview

CE 640 Biotechnological production of ethanol

From plant to biofuel

Using the CE 640 trainer you can go through the whole process used to produce ethanol in laboratory scale. Ethanol is produced from raw materials containing starch and sugar, as a starting material for biofuels and many other products. When converting starch to ethanol, different conversion processes have to be conducted using enzymes and yeasts.

The starch is converted into sugar in the first tank by glucoamylase and alpha-amylase enzymes. The temperature and pH value are monitored and controlled while this process takes place.

After the material has been pumped over into the second tank and yeast has been added, the fermentation process takes place sealed off from the outside atmosphere. The yeast converts the sugar into ethanol and carbon dioxide. The carbon dioxide escapes into the environment via a fermentation lock. The temperature in the fermentation tank is monitored and regulated throughout the process.

Once the fermentation process has ended, the ethanol is separated from the waste materials using a distillation unit (still).



Thick-walled, highly polished and hammered pure copper distillation kettle.

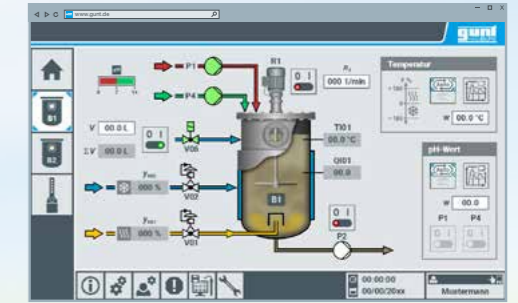

System control and data acquisition via PLC

The experimental plant is controlled by a PLC via a touch panel. The PLC allows the most important variables to be captured to the internal memory:

- temperature
 - pH value
 - fermentation temperature
 - water temperature
 - boiler temperature
 - bubble cap tray temperatures
 - dephlegmator temperature
 - condensate temperature
- } mash tank
} fermentation tank
} still

Learning objectives

- gelatinisation by steam injection
- liquefaction using alpha-amylase
- saccharification using glucoamylase
- fermentation: conversion of sugar to ethanol from yeast cultures under anaerobic conditions
- distillation: separation of ethanol from the mash

About the product:



CE 640

Biotechnological production of ethanol



screen mirroring is possible on different end devices

Description

- practical process for production of ethanol from starch-based biological raw materials
- plant control using a PLC via touch screen
- integrated router for operation and control via an end device and for screen mirroring on additional end devices: PC, tablet, smartphone

As well as its great importance for the chemical and foodstuffs industries, ethanol (alcohol) is increasingly used as a fuel. The CE 640 can be used to conduct realistic experiments for the production of ethanol from starch-based raw materials such as potatoes. The experimental plant consists of three main components: a mash tank, a fermentation tank and a distillation unit.

A mixture of water, finely chopped potatoes and alpha-amylase (enzyme) is filled into the mash tank. To dissolve the tightly packed starch chains in the potatoes, heating steam is injected into the mixture via a nozzle (gelatinisation). This increases the flow resistance of the mash, which would prevent further processes. The alpha-amylase breaks up the starch chains (liquefying) thereby reducing the flow resistance. Gluco-amylase is used to convert the starch into sugar (saccharification). This enzyme requires lower temperatures and pH values. The temperature is reduced using the water cooling jacket

around the mash tank, the pH value is adjusted by the addition of acid and caustic. After saccharification the mash is pumped into the fermentation tank. During the fermentation process in this tank, ethanol is produced. A water cooling system controls the temperature. After the fermentation process, the mash is pumped into the distillation unit. This is equipped with a bubble cap tray column for separation of the ethanol. Two tanks are available, one for the spent mash, the other for the distilled ethanol.

The experimental plant has comprehensive measurement, control and operating functions, which are controlled by a PLC via touch screen. By means of an integrated router, the system can alternatively be operated and controlled via an end device. The user interface can also be displayed on additional end devices (screen mirroring). Via the PLC, the measured values can be stored internally. Access to stored measured values is possible from end devices via WLAN with integrated router/LAN connection to the customer's own network.

The steam supply occurs via laboratory network or an optionally available electrical steam generator (CE 715.01).

Learning objectives/experiments

- familiarization with the necessary individual steps and system components for production of ethanol:
 - ▶ gelatinisation by steam injection
 - ▶ liquefaction by use of alpha-amylase
 - ▶ saccharification by use of gluco-amylase
 - ▶ fermentation: conversion of sugar into ethanol by yeast cultures under anaerobic conditions
 - ▶ distillation: separation of ethanol from the mash
- screen mirroring: mirroring of the user interface on end devices
 - ▶ menu navigation independent of the user interface shown on the touch screen
 - ▶ different user levels available on the end device: for observing the experiments or for operation and control

CE 640

Biotechnological production of ethanol

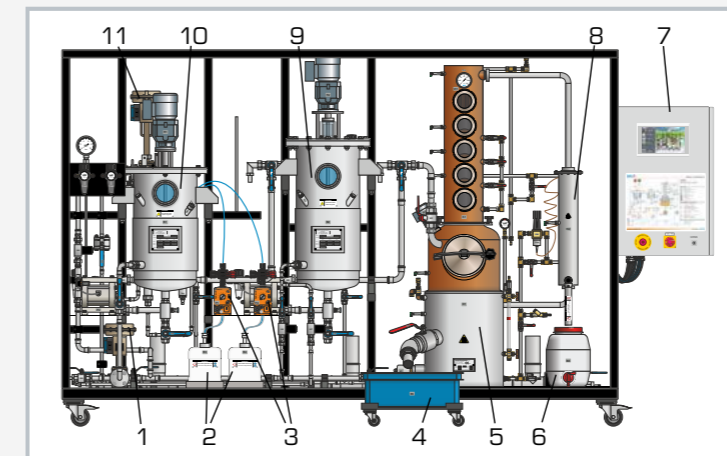

1 cooling water control valve, 2 acid/caustic tanks, 3 acid/caustic pumps, 4 spent mash tank (mobile), 5 distillation unit, 6 product tank, 7 switch cabinet, 8 condenser, 9 fermentation tank, 10 mash tank, 11 steam pressure control valve

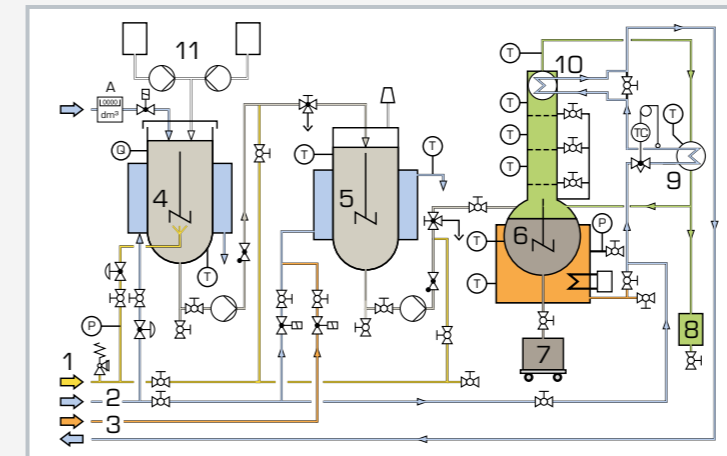

1 heating steam, 2 cooling water, 3 heating water, 4 mash tank, 5 fermentation tank, 6 distillation unit, 7 spent mash tank, 8 product tank, 9 condenser, 10 dephlegmator, 11 acid/caustic pumps and tanks; P pressure, T temperature, A water quantity, Q pH value

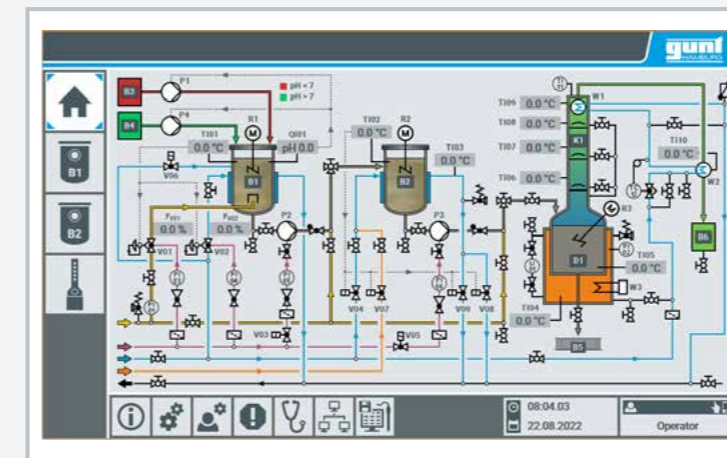

Screenshot of the touch screen for the PLC control unit

Specification

- batch conversion of starch-based raw materials into ethanol
- open mash tank with water-jacket cooling, steam injection and stirrer
- closed fermentation tank with stirrer and water-jacket cooling/heating
- distillation unit with 3 bubble cap trays, dephlegmator, condenser and stirrer
- 2 pumps for delivering the mash
- pH value control in the mash tank with acid and caustic delivered by metering pumps
- adjustment of the amount of injected heating steam, the cooling water flow rates and the head temperature by means of PID controllers
- plant control using a PLC; operated by touch screen
- integrated router for operation and control via an end device and for screen mirroring: mirroring of the user interface on up to 5 end devices
- data acquisition via PLC on internal memory, access to stored measured values via WLAN with integrated router/LAN connection to customer's own network

Technical data

PLC: Eaton XV303

Mash tank: 40L
 Fermentation tank: 50L
 Product tank: 10L
 Spent mash: 30L
 Distillation unit
 ■ column: D x H: 220 x 1200 mm
 ■ sump capacity: 45L
 ■ sump heater: 0...7500W

2 air-operated diaphragm pumps
 ■ drive pressure: 2 bar
 ■ max. flow rate: 15L/min
 ■ max. head: 20m
 ■ max. solid lump size: 4mm
 2 metering pumps (acid and caustic)
 ■ max. flow rate: each 2,1L/h

Measuring ranges
 ■ temperature: 10x 0...150°C
 ■ flow rate: 0...25L/min (to mash tank)
 ■ pH value: 2...10
 ■ pressure: 0...10 bar (steam)

400V, 50Hz, 3 phases; 400V, 60Hz, 3 phases
 230V, 60Hz, 3 phases; UL/CSA optional
 L x W x H: 3500 x 1200 x 2000 mm; Weight: approx. 500kg

Required for operation

compressed air (1,5...6 bar), cold and hot water connection (min. 400L/h, 40°C), drain, CE 715.01 or steam (10kg/h, min. 3 bar)

Scope of delivery

experimental plant, 1 set of enzymes etc., 1 set of accessories, 1 set of instructional material

Basic knowledge

Biogas

Increasing energy demand and the limitation of fossil energy sources require new approaches to ensure the energy supply. In addition to solar and wind energy, energy production from biomass is an important component of future energy concepts.

In a biogas plant, microorganisms, in the absence of light and oxygen, biodegrade the organic starting materials (substrate). The product of this anaerobic degradation is a gas mixture predominantly consisting of methane. This gas mixture is known as biogas.



The complex processes of anaerobic degradation can be divided into four consecutive phases.

Phase 1: Hydrolysis

The substrate used in biogas plants is in the form of unresolved, high-molecular-weight compounds such as proteins, fats and carbohydrates. Therefore, these compounds must first be broken down into their individual components. The products of hydrolysis are amino acids, sugars and fatty acids.

Phase 2: Acidification

From the products of hydrolysis, there now emerges the biochemical degradation of mainly propionic acid, butyric acid, acetic acid, alcohols, hydrogen and carbon dioxide.

Phase 3: Acetic acid formation

The products from the previous phase are then converted into acetic acid, hydrogen and carbon dioxide.

Phase 4: Methane formation

Methane bacteria can utilize either acetic acid (CH_3COOH) or carbon dioxide and hydrogen for their metabolism. The following two biochemical reactions can lead to the formation of methane (CH_4):

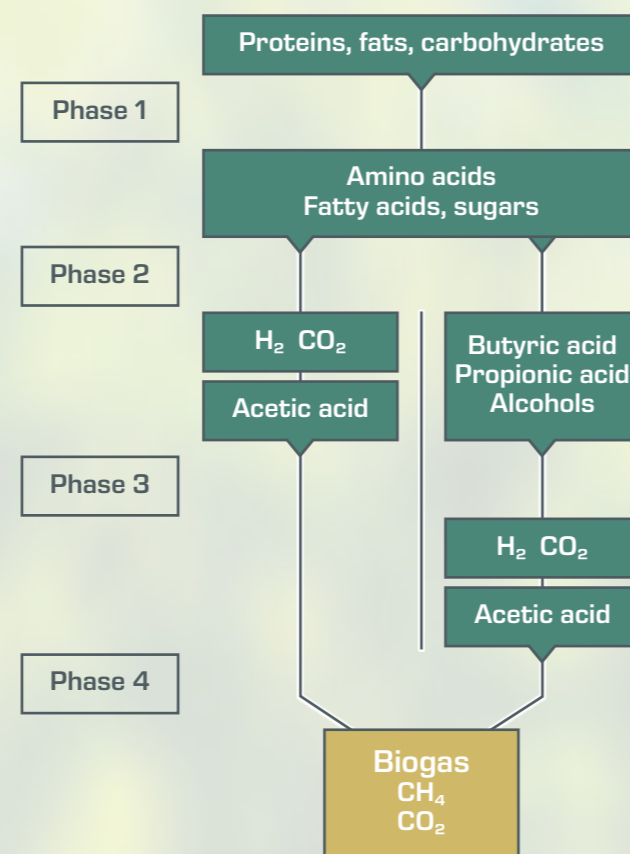
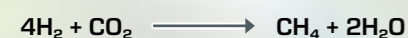
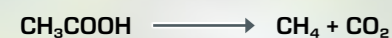

Basic principle of anaerobic degradation

Ambient conditions

The microorganisms involved in the anaerobic degradation have different requirements as regards the ambient conditions. This relates primarily to the pH value and the temperature. In particular, the methane bacteria are very sensitive to deviations of these two process variables from their optimum value. If all the four phases of degradation take place in a reactor, it is necessary to find a compro-

mise in terms of temperature and pH value. This results in a lower biogas yield. From a process engineering point of view, a two-stage process control in two separate reactors is more practical. In this way, the ambient conditions can be better adapted to the respective microorganisms.

Use of biogas

The resulting biogas can then be burned in a combined heat and power plant. This converts the energy stored in the biogas into rotational energy. An attached generator in turn generates electricity. A combined heat and power plant produces heat in addition to electrical energy, which can be used to heat the reactor or the premises.

Principle of operation of a biogas plant:

- 1 slurry from livestock farming
- 2 renewable raw materials (e.g. maize)
- 3 storage for comminuted raw materials
- 4 storage for feeding the bioreactor
- 5 bioreactor (fermenter)
- 6 digestate storage tank
- 7 biogas treatment
- 8 combined heat and power plant
- 9 water circuit for heating the bioreactor
- 10 feed-in of electricity into the public grid
- 11 digestate (use as fertiliser)

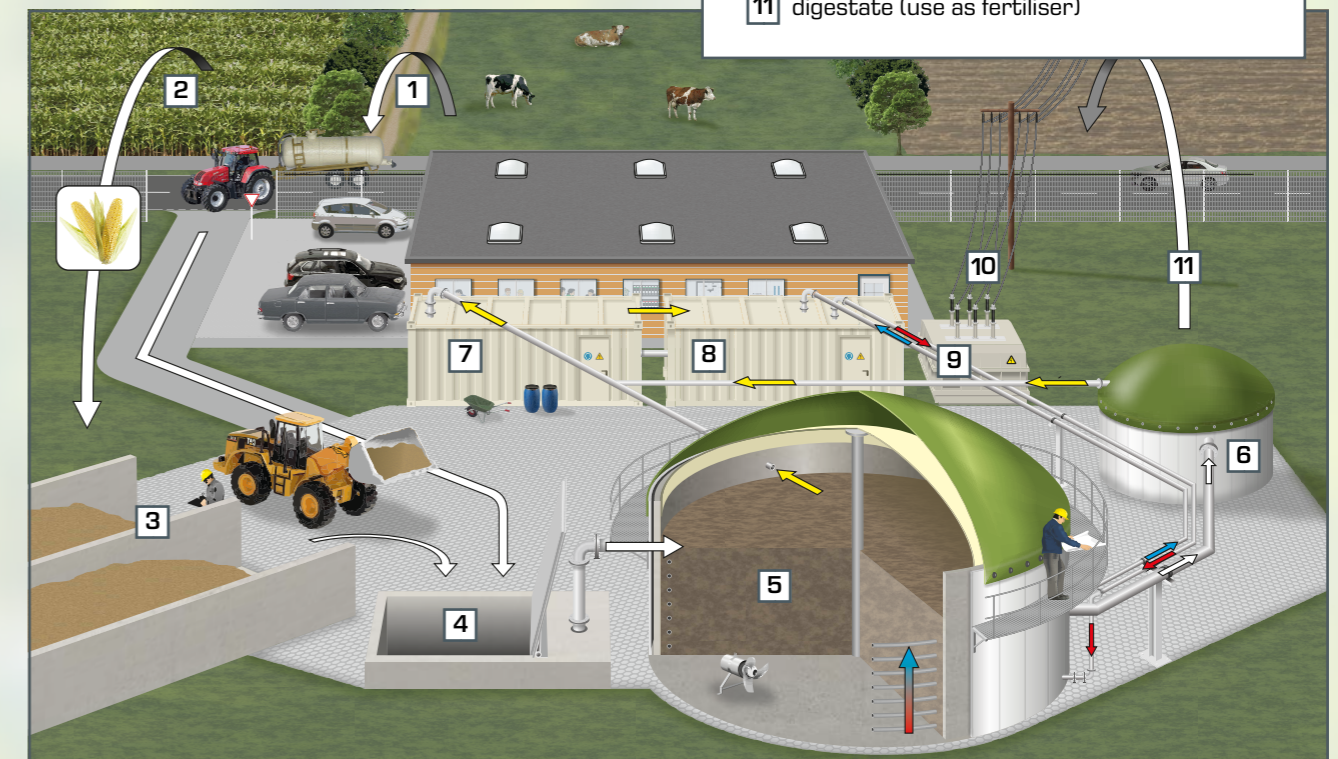

CE 642 Biogas plant



The illustration shows from left to right: supply unit, trainer and post-fermentation unit; screen mirroring is possible on different end devices

Description

- two-stage biogas plant
- extensive biogas analysis
- plant control using a PLC via touch screen
- integrated router for operation and control via an end device and for screen mirroring on additional end devices: PC, tablet, smartphone

In a biogas plant, microorganisms biologically degrade the organic starting substances (substrate) under exclusion of light and oxygen. The product of this anaerobic degradation is a gas mixture which primarily consists of methane. This gas mixture is called biogas.

The experimental plant CE 642 serves to demonstrate the generation of biogas in a practical manner. The substrate is a suspension of shredded organic solids. It is hydrolysed and acidified in the first stirred tank reactor. Here, anaerobic microorganisms convert the long-chain organic substances into short-chain organic substances. The biogas forms in the second stirred tank reactor in the last step of the anaerobic degradation. It contains mainly methane and carbon dioxide. This two-stage method enables the ambient conditions to be adjusted and optimised in both reactors separately. The digestate is collected in a separate tank.

Temperature and pH value are controlled in both reactors. The resulting biogas is dried in a column. The column is filled with silica gel. Subsequently, the flow rate, humidity, methane content, carbon dioxide content and temperature of the biogas are measured. The system is controlled by the PLC via touch screen. By means of an integrated router, the system can alternatively be operated and controlled via an end device. The user interface can also be displayed on additional end devices (screen mirroring). Via the PLC, the measured values can be stored internally. Access to stored measured values is possible from end devices via WLAN with integrated router/LAN connection to the customer's own network.

The experimental plant enables both a continuous and a discontinuous (batch) operation mode. Anaerobic biomass from a biogas plant is required for the experiments. E.g. potatoes or maize can be used to produce the substrate. An inert gas (e.g. carbon dioxide) is required to flush the experimental plant.

Learning objectives/experiments

- achieving a stable operating state
- influence of the following parameters on the biogas generation
 - ▶ temperature
 - ▶ substrate
 - ▶ volumetric loading
 - ▶ pH value
- influence of the operation mode on the biogas yield
 - ▶ single stage or dual stage
 - ▶ with and without post-fermentation
 - ▶ continuous and discontinuous
- determining the following parameters depending on the operating conditions
 - ▶ biogas yield
 - ▶ biogas flow rate
 - ▶ biogas quality
- screen mirroring: mirroring of the user interface on end devices
 - ▶ menu navigation independent of the user interface shown on the touch screen
 - ▶ different user levels available on the end device: for observing the experiments or for operation and control

CE 642 Biogas plant

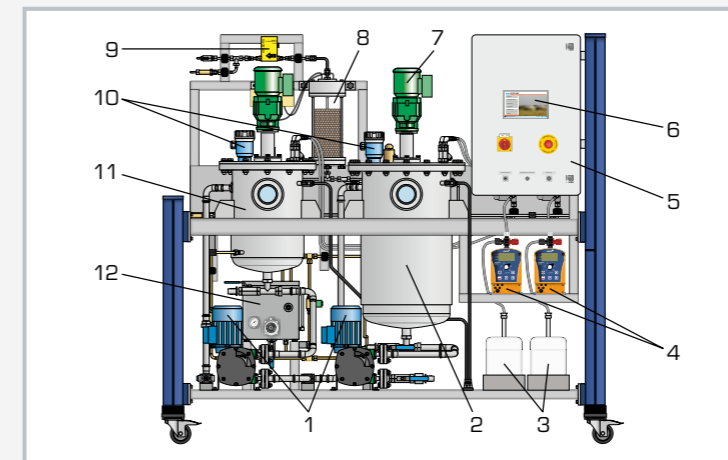

1 peristaltic pumps, 2 reactor (stage 2), 3 tanks for acid and caustic, 4 metering pumps, 5 switch cabinet, 6 PLC with touch screen, 7 stirring machine, 8 drying column, 9 flow meter (biogas), 10 capacitive level sensors, 11 reactor (stage 1), 12 heating water tank

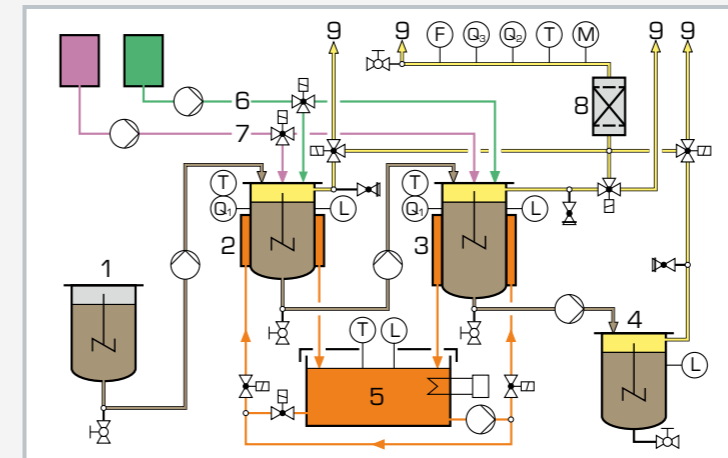

1 substrate tank, 2 reactor (stage 1), 3 reactor (stage 2), 4 digestate tank, 5 heating water, 6 acid, 7 caustic, 8 drying column, 9 biogas; F flow rate, L level, M humidity, Q₁ pH value, Q₂ methane content, Q₃ carbon dioxide content, T temperature

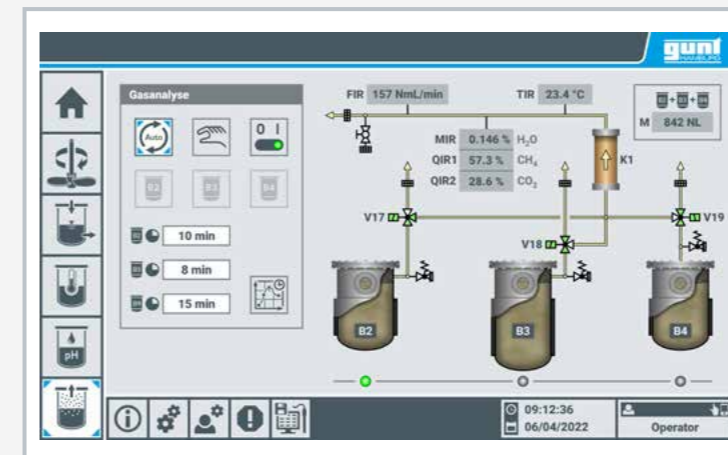

Operating interface of the PLC: menu item "gas analysis"

Specification

- [1] two-stage biogas plant (continuous or discontinuous operation possible)
- [2] 2 stirred tank reactors made of stainless steel with capacitive level sensors
- [3] separate supply unit with substrate tank and feed pump
- [4] control of temperature and pH value in the reactors
- [5] 2 metering pumps for acid and caustic
- [6] heating water circuit with tank, heater, temperature controller and pump
- [7] biogas is dried with silica gel
- [8] biogas analysis: flow rate, methane content, carbon dioxide content, humidity and temperature
- [9] plant control with PLC via touch screen
- [10] integrated router for operation and control via an end device and for screen mirroring: mirroring of the user interface on up to 5 end devices
- [11] data acquisition via PLC on internal memory, access to stored measured values via WLAN with integrated router/LAN connection to customer's own network

Technical data

PLC: Eaton XV303

Tanks made of stainless steel

- reactor (stage 1): 26,3L
- reactor (stage 2): 73,5L
- substrate tank: approx. 30L
- digestate tank: 26,3L

Pumps

- 3 peristaltic pumps: each max. 25L/h
- 2 metering pumps: each max. 2,1L/h
- heating water pump: max. 480L/h

Stirring machines

- substrate tank: max. 200min⁻¹
- reactors: each max. 120min⁻¹

Measuring ranges

- methane content: 0...100%
- carbon dioxide content: 0...100%
- flow rate: 0...30NL/h (biogas)
- pH value: 2x 1...14
- humidity: 0...100%
- temperature: 3x 0...100°C (reactors and biogas)

400V, 50Hz, 3 phases; 400V, 60Hz, 3 phases
230V, 60Hz, 3 phases; UL/CSA optional
LxWxH: 1100x790x1400mm (supply unit)
LxWxH: 2060x790x1910mm (trainer)
LxWxH: 1100x790x1400mm (post-fermentation unit)
Total weight: approx. 770kg

Required for operation

biomass from a biogas plant, substrate (recommendation: potatoes or maize), caustic soda, hydrochloric acid, inert gas (e.g. carbon dioxide) 5kg/h, min. 2bar; water connection + drain 300L/h, min. 3bar; exhaust air + ventilation 245m³/h

Scope of delivery

- 1 experimental plant, 1 packing unit of silica gel
- 1 set of accessories, 1 set of instructional material



Pilot plants

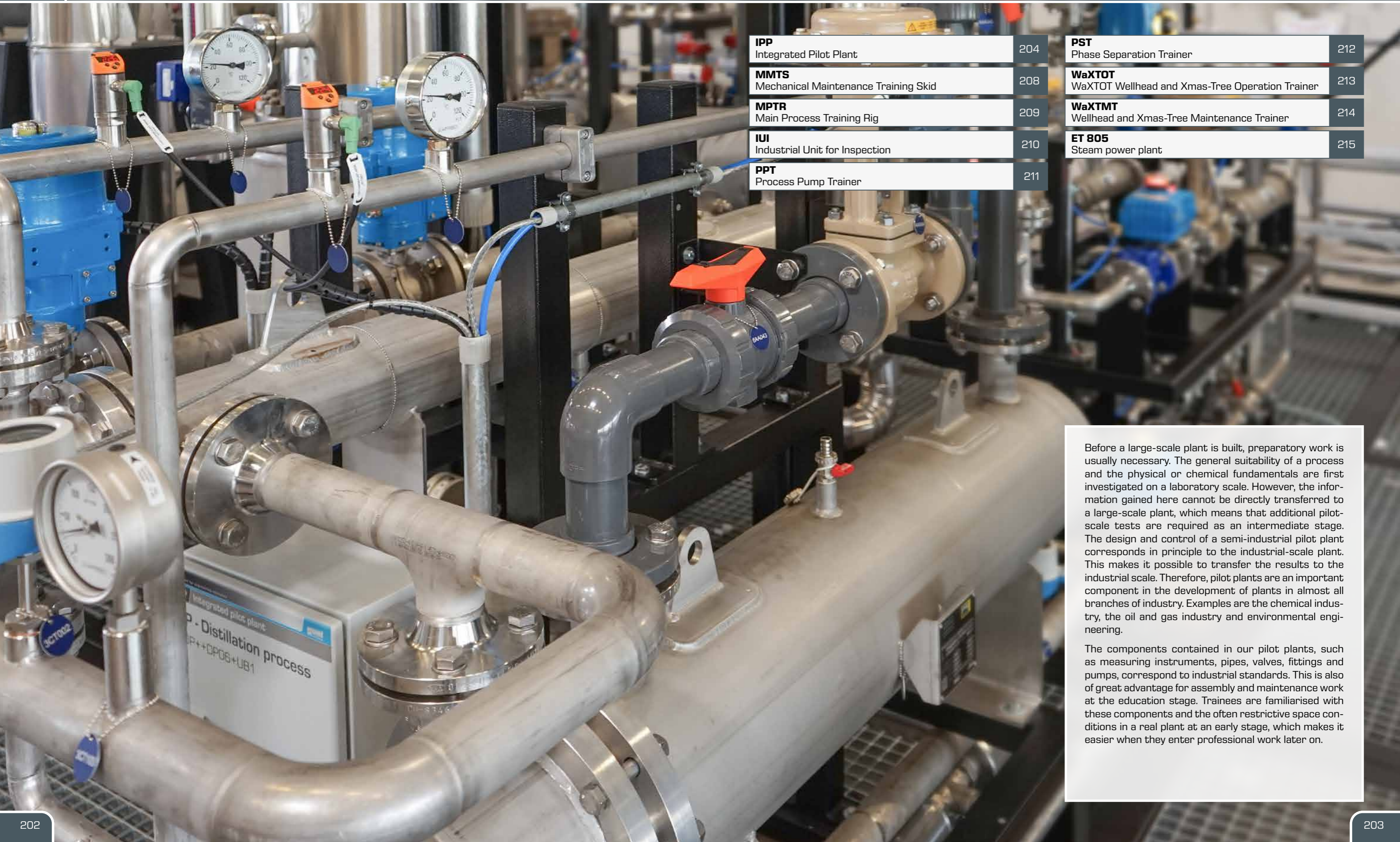

IPP Integrated Pilot Plant	204
MMTS Mechanical Maintenance Training Skid	208
MPTR Main Process Training Rig	209
IUI Industrial Unit for Inspection	210
PPT Process Pump Trainer	211

PST Phase Separation Trainer	212
WaXTOT WaXTOT Wellhead and Xmas-Tree Operation Trainer	213
WaXTMT Wellhead and Xmas-Tree Maintenance Trainer	214
ET 805 Steam power plant	215

Before a large-scale plant is built, preparatory work is usually necessary. The general suitability of a process and the physical or chemical fundamentals are first investigated on a laboratory scale. However, the information gained here cannot be directly transferred to a large-scale plant, which means that additional pilot-scale tests are required as an intermediate stage. The design and control of a semi-industrial pilot plant corresponds in principle to the industrial-scale plant. This makes it possible to transfer the results to the industrial scale. Therefore, pilot plants are an important component in the development of plants in almost all branches of industry. Examples are the chemical industry, the oil and gas industry and environmental engineering.

The components contained in our pilot plants, such as measuring instruments, pipes, valves, fittings and pumps, correspond to industrial standards. This is also of great advantage for assembly and maintenance work at the education stage. Trainees are familiarised with these components and the often restrictive space conditions in a real plant at an early stage, which makes it easier when they enter professional work later on.

IPP Integrated Pilot Plant

This plant demonstrates the operation of a plant with a water/ethylene glycol mixture as the main medium. The plant combines components of conventional field processes with tanks, heat exchangers, pumps and cooling sections as well as control of a distillation process. The plant consists of four functional units:

- supply unit (outdoor)
- supply unit (indoor)
- distillation process
- field process

This plant focuses on the commissioning, operation, shutdown and maintenance of a typical process engineering process on an industrial scale. Further didactic focal points are:

- behaviour of control loops for temperature, pressure, level and flow rate
- setting parameters at PID controllers (proportional, integral, derivative)
- reading piping and instrumentation diagrams (P&IDs)
- locating components in the plant
- pump operating modes
 - ▶ single operation
 - ▶ in-series operation
 - ▶ parallel operation
- operation of a professional process control system (DeltaV™)

Distillation process

- 7 evaporator (bottom product)
- 8 rectification column

Field process

- 9 heat exchangers
- 10 receiving tanks
- 11 pumping stations

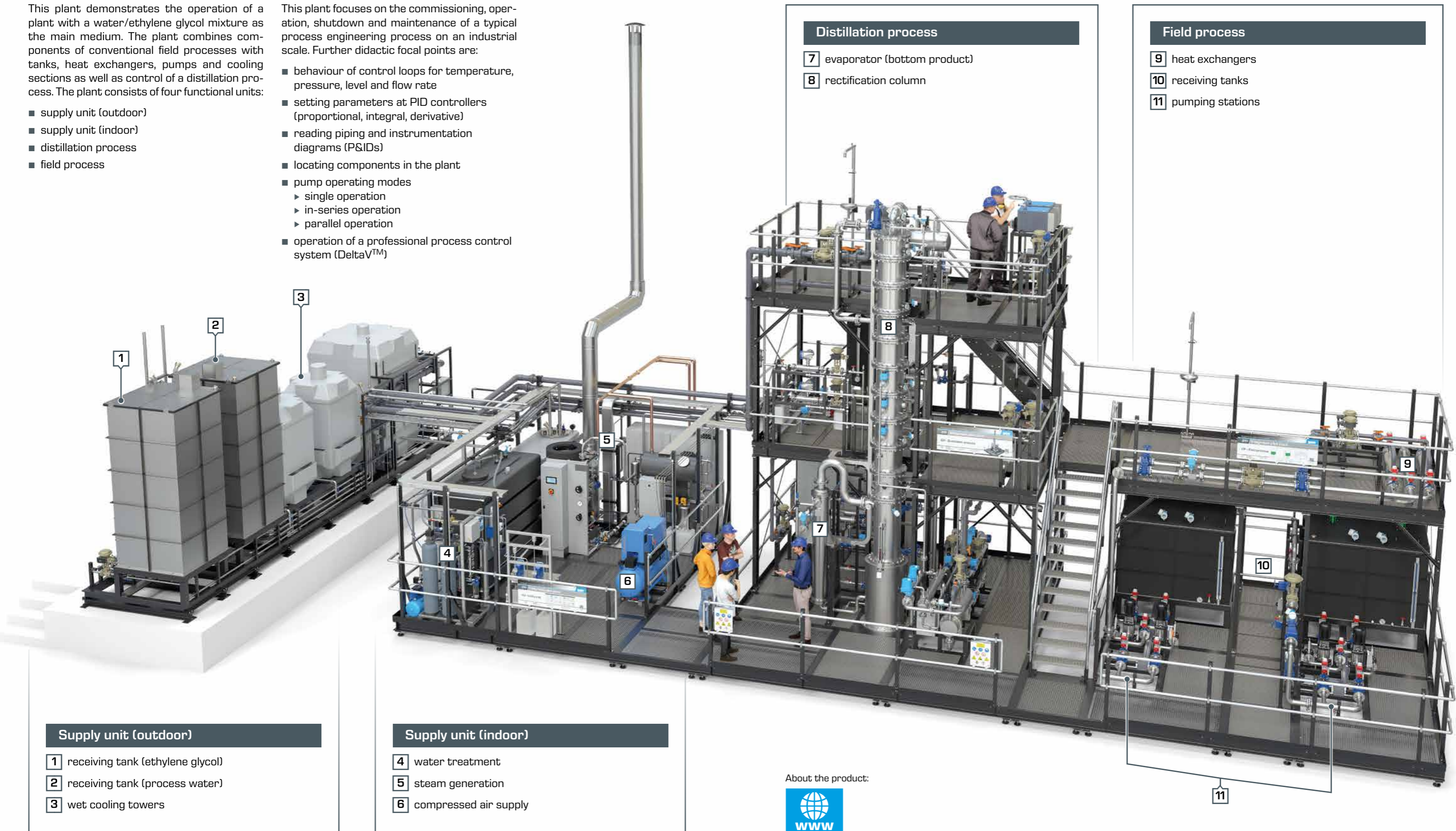

Supply unit (outdoor)

- 1 receiving tank (ethylene glycol)
- 2 receiving tank (process water)
- 3 wet cooling towers

Supply unit (indoor)

- 4 water treatment
- 5 steam generation
- 6 compressed air supply

About the product:



MMTS Mechanical Maintenance Training Skid

The MMTS training system is used for the maintenance of mechanical components as well as the measurement, control of various parameters in a piping system with several media. In real-world applications, such systems can be found in power plants as well as in mineral oil processing and natural gas processing plants. In contrast to industrial applications, the training system does not contain any actual engines or turbines. The heat input of these machines is simulated by heating lubricating oil with a heater. In the core process of the training system, the heat generated in this way is dissipated via a heat exchanger and cooling water circuit.

Various sensors record pressure, flow rate, fill level and temperature. The training system is operated via a touch screen in the switch cabinet using SCADA (Supervisory Control and Data Acquisition). Measurement data is recorded via additional software running on a PC.

- lubricating oil circuit with lubricating oil tank, 2 pumps, heater and lubricating oil cooler
- cooling water circuit with cooling water tank and 3 pumps for cooling the lubricating oil via the lubricating oil cooler
- hydraulic oil circuit with hydraulic oil tank, pressure accumulator and pump to supply hydraulically driven valves
- compressed air supply with 2 compressors and pressure vessel to supply compressed air to pneumatic actuators of the control valves
- cooling tower circuit with cooling tower and cooling tower sump for re-cooling of the cooling water circuit via the secondary water cooler

About the product:

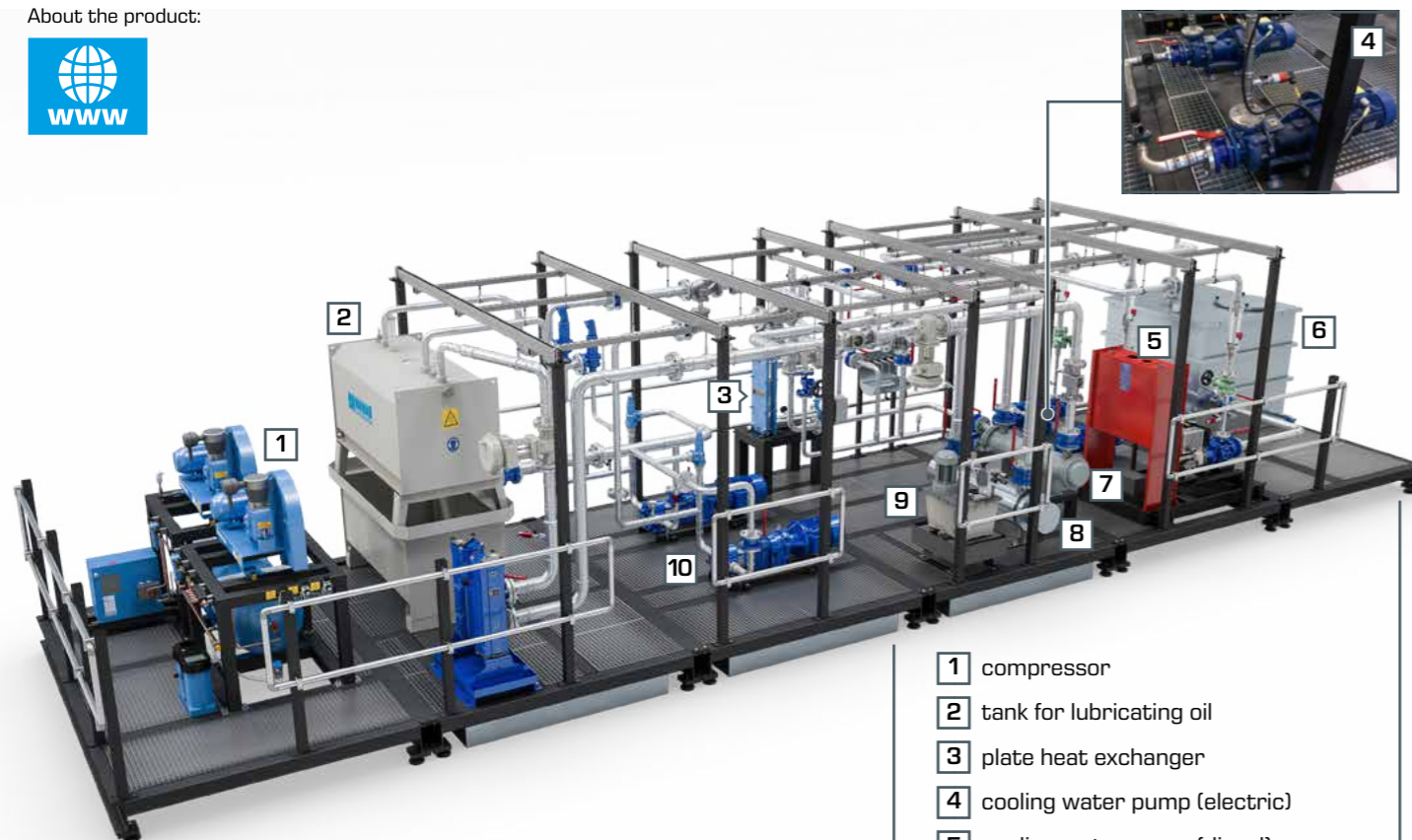

- 1 compressor
- 2 tank for lubricating oil
- 3 plate heat exchanger
- 4 cooling water pump (electric)
- 5 cooling water pump (diesel)
- 6 cooling water tank
- 7 shell-and-tube heat exchanger
- 8 lubricating oil heater
- 9 supply unit for hydraulic oil
- 10 oil pumps

The Jubail Technical Institute (JTI) in Saudi Arabia is one of the leading institutes in the field of engineering education. At the institute, 80% of the curriculum is dedicated to practical aspects. The MMTS training system fits perfectly into this educational concept.



MPTR Main Process Training Rig

The MPTR training device is based entirely on industrial technologies. It represents a complex project task for the training of piping and plant engineers as well as for maintenance technicians. Mechanical, electrical and hydraulic topics can be covered in this plant. The plant is divided into two units:

Unit 1: flow and level control

Unit 2: flow, level and temperature control

Each unit contains a complete process circuit with pumps, tanks and the necessary pipes. It contains a variety of fittings and measuring instruments. The plant also includes typical industrial components such as heat exchangers, filters or heaters. This results in a realistic industrial situation. The design of the plant requires working in confined spaces, at heights or under other equipment components. This gives the trainee a realistic environment like it can be found in industrial plants.

Both units are mechanically, hydraulically and electrically independent of each other. Two separate switch cabinets are available for the two units. Each unit is operated from its own touch screen.

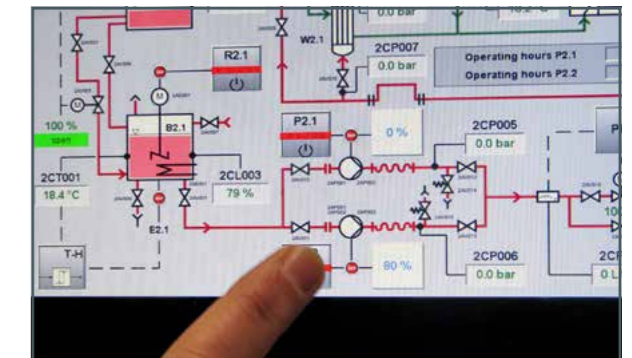

Operation with touch screen



About the product:



As with all pilot plants, high-quality industrial components ensure maximum practical relevance and prepare trainees for their later professional activities.



IUI Industrial Unit for Inspection

Knowledge of industrial components plays an important role in the training of industrial testers. In order to acquire this knowledge, it is very helpful to practise on real-scale plants. This is why GUNT has developed a demonstration unit that contains the most important components of a process plant. Care was taken to ensure that all components used can be found in a real environment. This makes it easier for the trainees to familiarise themselves with a typical process plant, to understand the function of individual parts and the interaction of all components. The demonstration unit consists of three parts:

- thermal reactor with chemical injection system
- steam driven auxiliary pumping station
- compressed air station

All of these parts are connected via pipes and valves. A variety of electrical components such as cables, switches, contactors, displays, fuses and a switch cabinet show typical electrical cabling as in a real-world plant.



Thermal reactor with chemical injection system

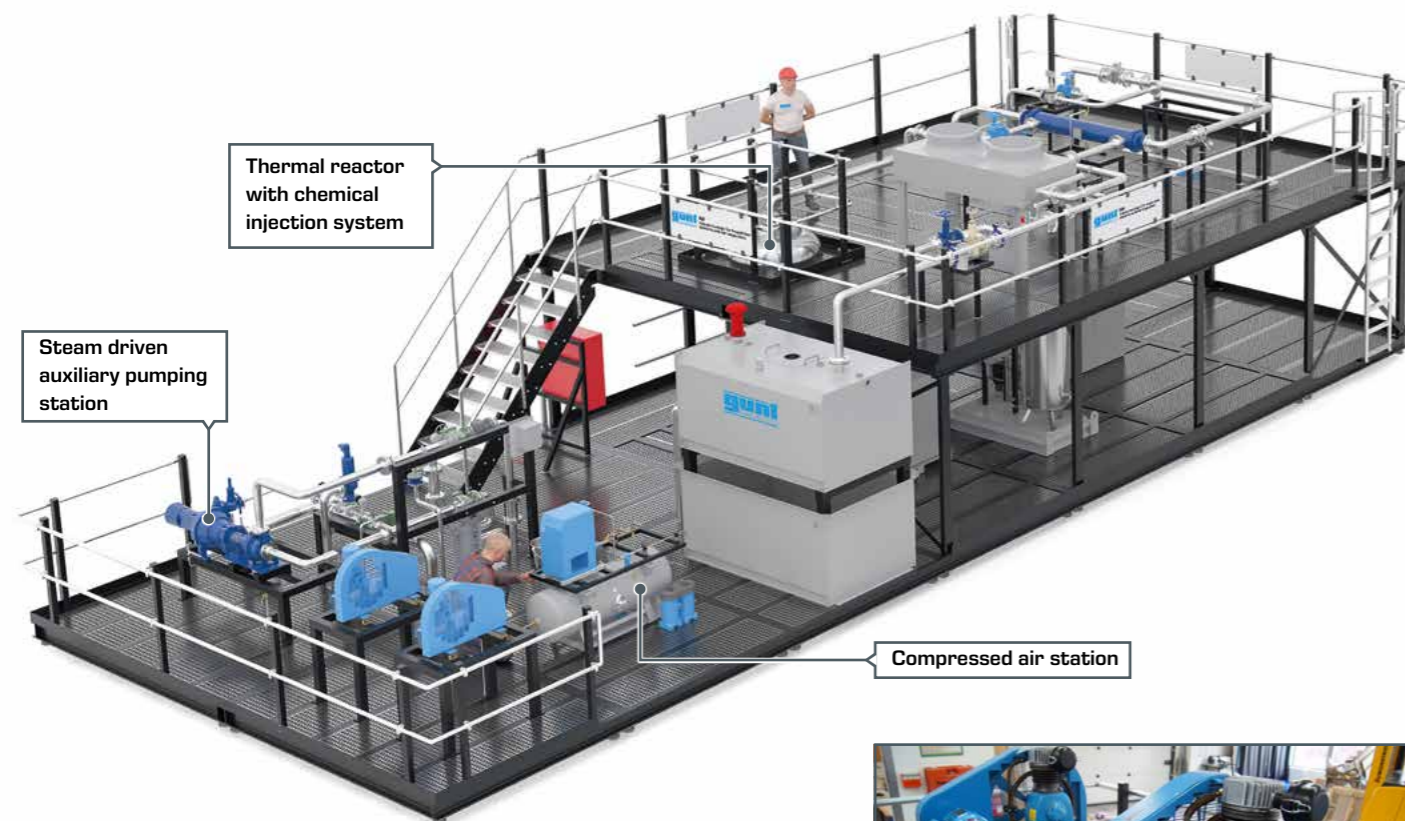

Thermal reactor with chemical injection system

Steam driven auxiliary pumping station

Compressed air station



Compressed air station



Steam driven auxiliary pumping station

About the product:



PPT Process Pump Trainer

In the oil industry, crude oil is extracted from a well and then pumped for further processing. In the Process pump trainer (PPT), three different types of pumps are operated in different modes and compared with each other. The working medium is a mixture of air, water and oil in order to simulate crude oil. After passing through the pump section, the synthetic crude oil is split into oil, water and air by phase separation and then mixed again to ensure a homogeneous composition.

The trainer consists of three pump units and a supply unit. Each pump unit is equipped with two identical pumps. The pump types used are:

- pump unit 1: single-stage centrifugal pumps
- pump unit 2: multistage centrifugal pumps
- pump unit 3: multi-phase twin screw pumps

The plant contains four different and high-quality flow meters:

- Coriolis flowmeter
- electromagnetic flow meter
- oval gear flow meter
- thermal mass flow meter

Process control system

The **DeltaV™** process control system from **Emerson Electric Co.** is used to control the plant. This automation system is very user-friendly and widely used in the process engineering and energy industries. DeltaV™ has modern control functions and allows the operator to optimally control the plant at all times.

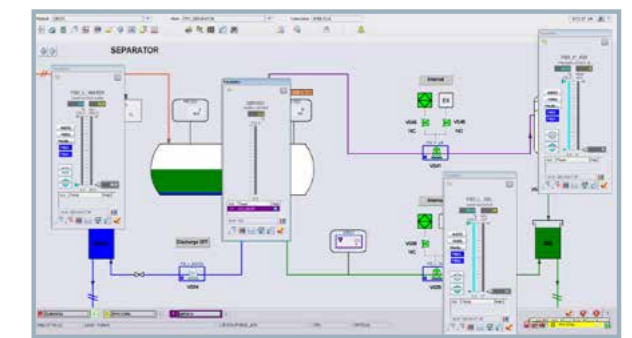

Visualisation of the process control system DeltaV™

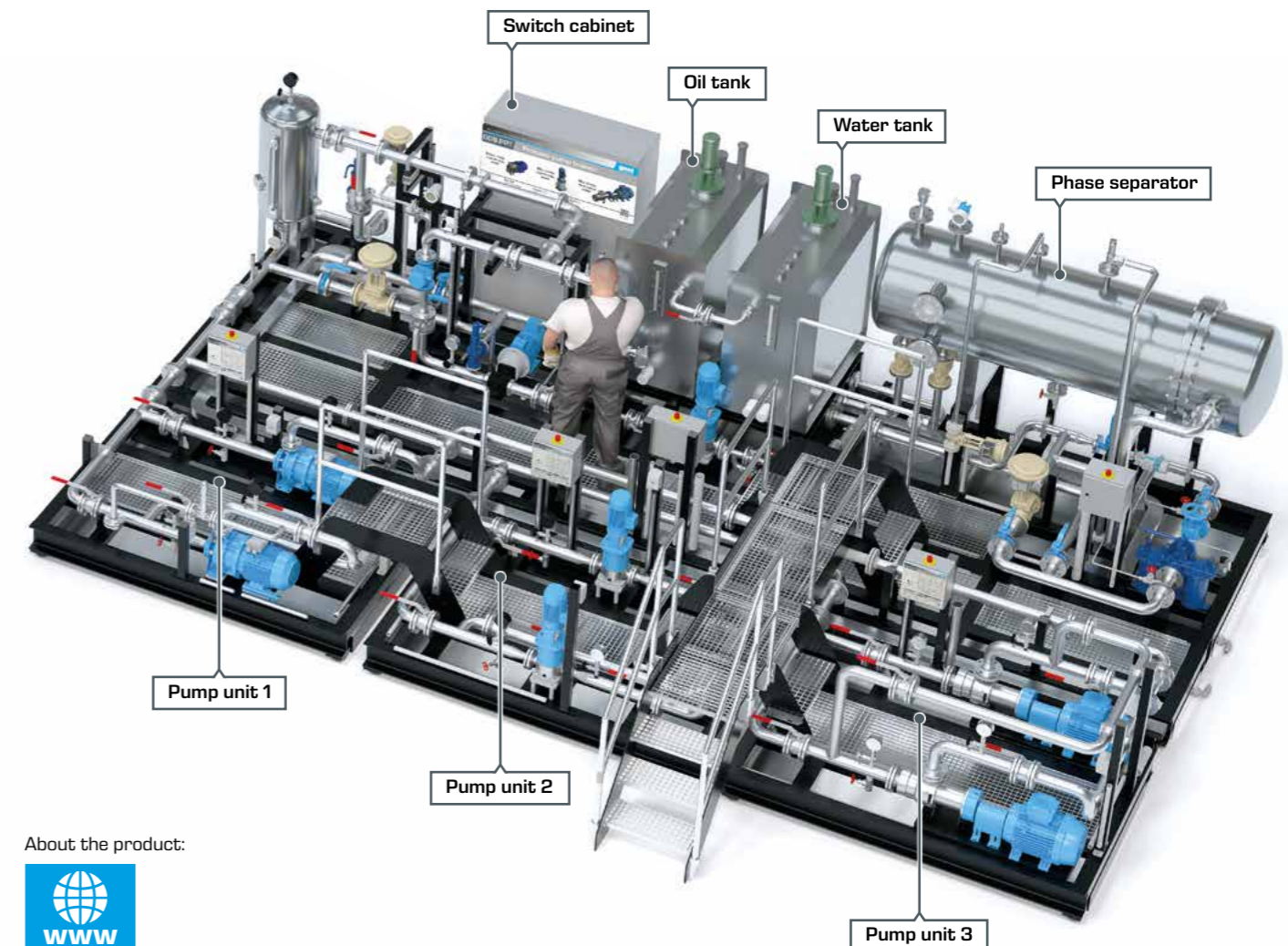

Switch cabinet

Oil tank

Water tank

Phase separator

Pump unit 1

Pump unit 2

Pump unit 3

About the product:



PST Phase Separation Trainer

About the product:

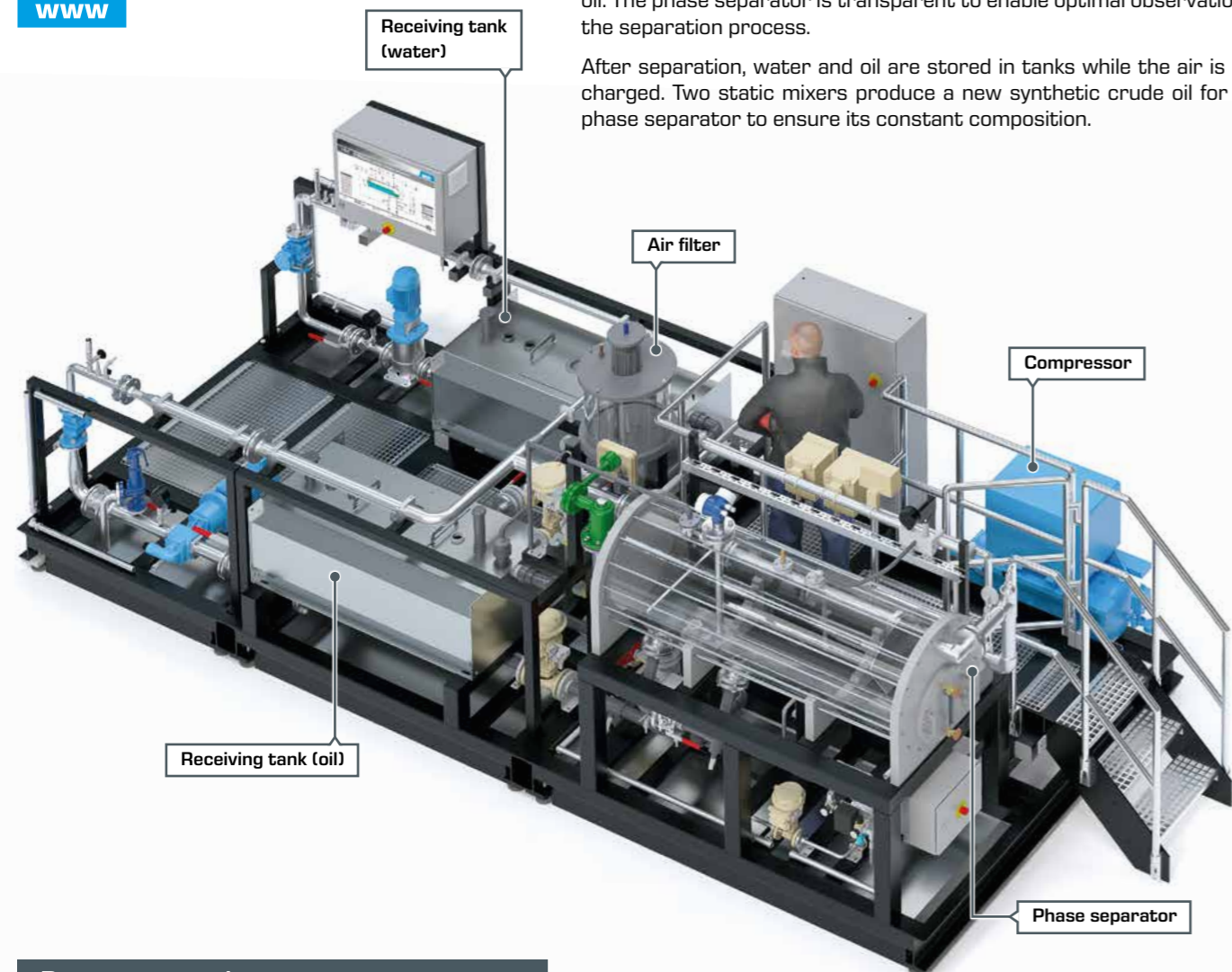

This plant demonstrates the separation of simulated crude oil into air, water and oil. The main component of the plant is a phase separator that uses a vortex-shaped inlet and gravity to separate the simulated crude oil. The phase separator is transparent to enable optimal observation of the separation process.

After separation, water and oil are stored in tanks while the air is discharged. Two static mixers produce a new synthetic crude oil for the phase separator to ensure its constant composition.

Process control system

The **DeltaV™** process control system from **Emerson Electric Co.** is used to control the plant. This automation system is very user-friendly and widely used in the process engineering and energy industries.

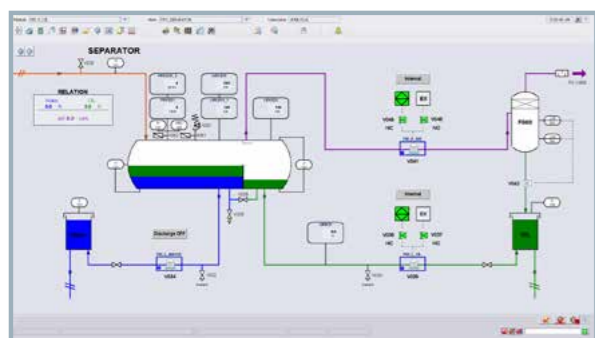

Visualisation of the process control system DeltaV™



Phase separator

WaXTOT Wellhead and Xmas-Tree Operation Trainer

In the oil industry, crude oil is extracted from a well and then pumped for further processing. A wellhead is installed at the top of the oil well as an interface between the drilling equipment and production equipment. A 'Christmas tree' (Xmas-tree) is connected to the wellhead with valves, coils and fittings for oil processing.

In this plant, a simulated crude oil is pumped through a wellhead and a Xmas-tree. The synthetic crude oil is then split into oil, water and air by phase separation and mixed again to ensure a homogeneous composition.

The Xmas-tree contains the lower and upper main valves, wing valves and flow control valves to control the flow rate. A commercially available control panel is used to control the safety functions and the extraction. The **DeltaV™** process control system from **Emerson Electric Co.** is used to control the plant. This system is very common in the process and energy industry.

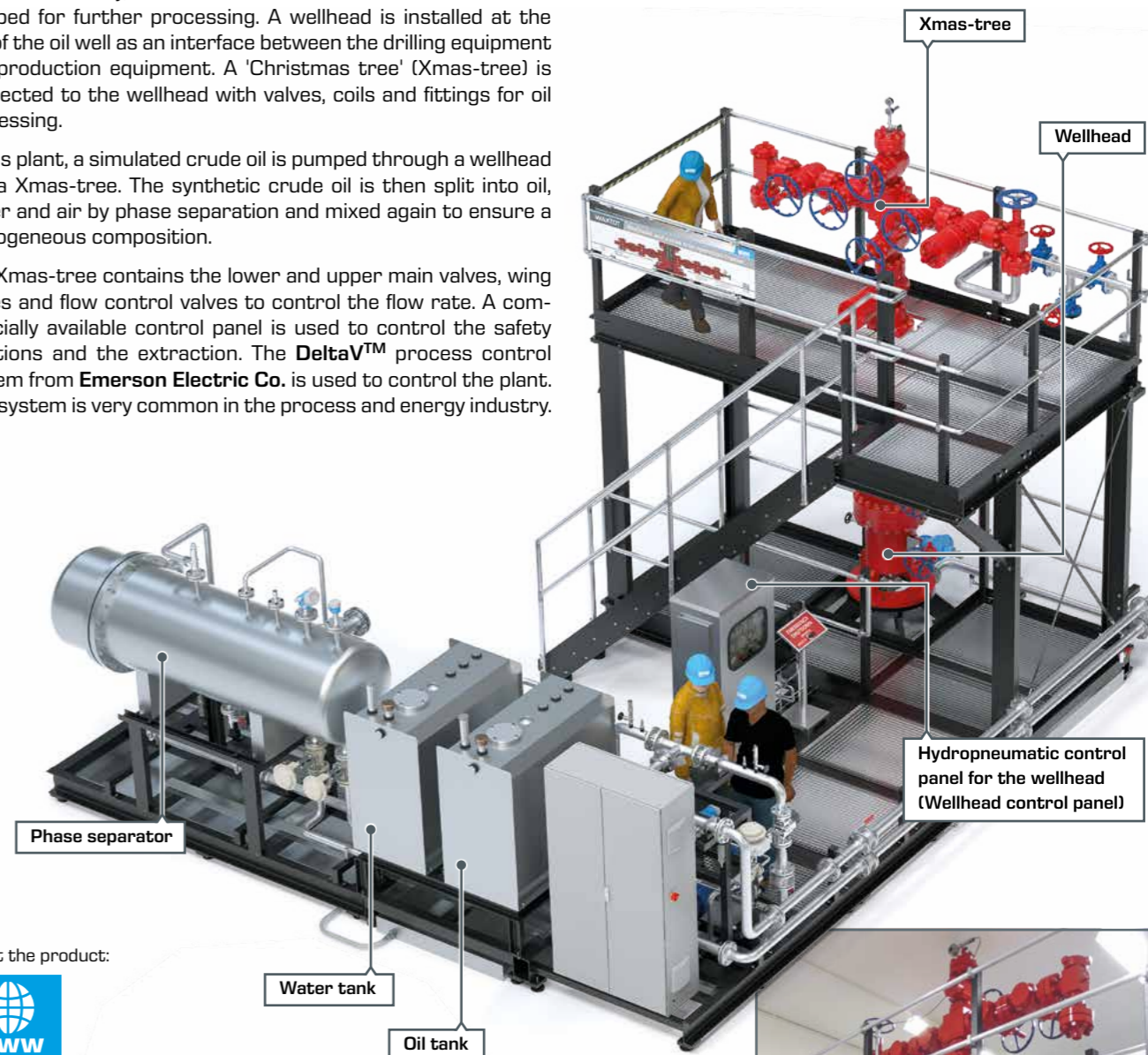

About the product:

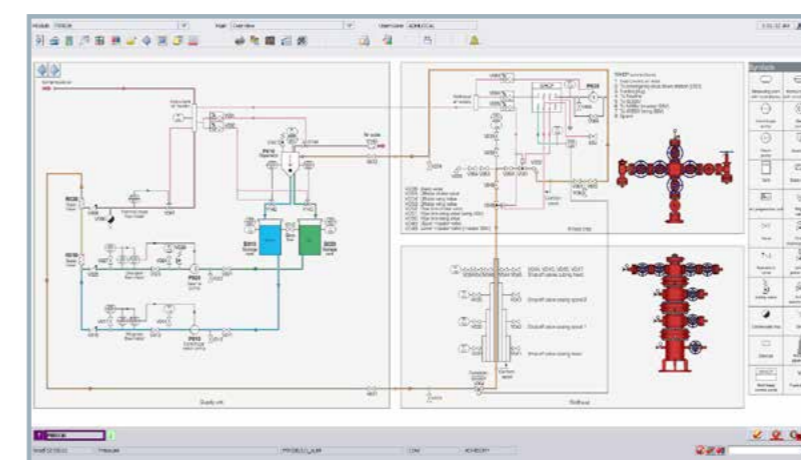

Visualisation of the process control system DeltaV™



Wellhead and Xmas-tree

WaXTMT Wellhead and Xmas-Tree Maintenance Trainer

In the oil industry, crude oil is extracted from a well and then pumped for further processing. A wellhead is installed at the top of the oil well as an interface between the drilling equipment and production equipment. A 'Christmas tree' (Xmas-tree) is connected to the wellhead with valves, coils and fittings for oil processing.

WaXTMT shows the assembly of a wellhead and a Xmas-tree. The plant is used to assemble and disassemble the wellhead and the Xmas-tree. No liquids are pumped through the trainer. The tools required for the work are included.



Assembly and disassembly of the wellhead and the Xmas-tree

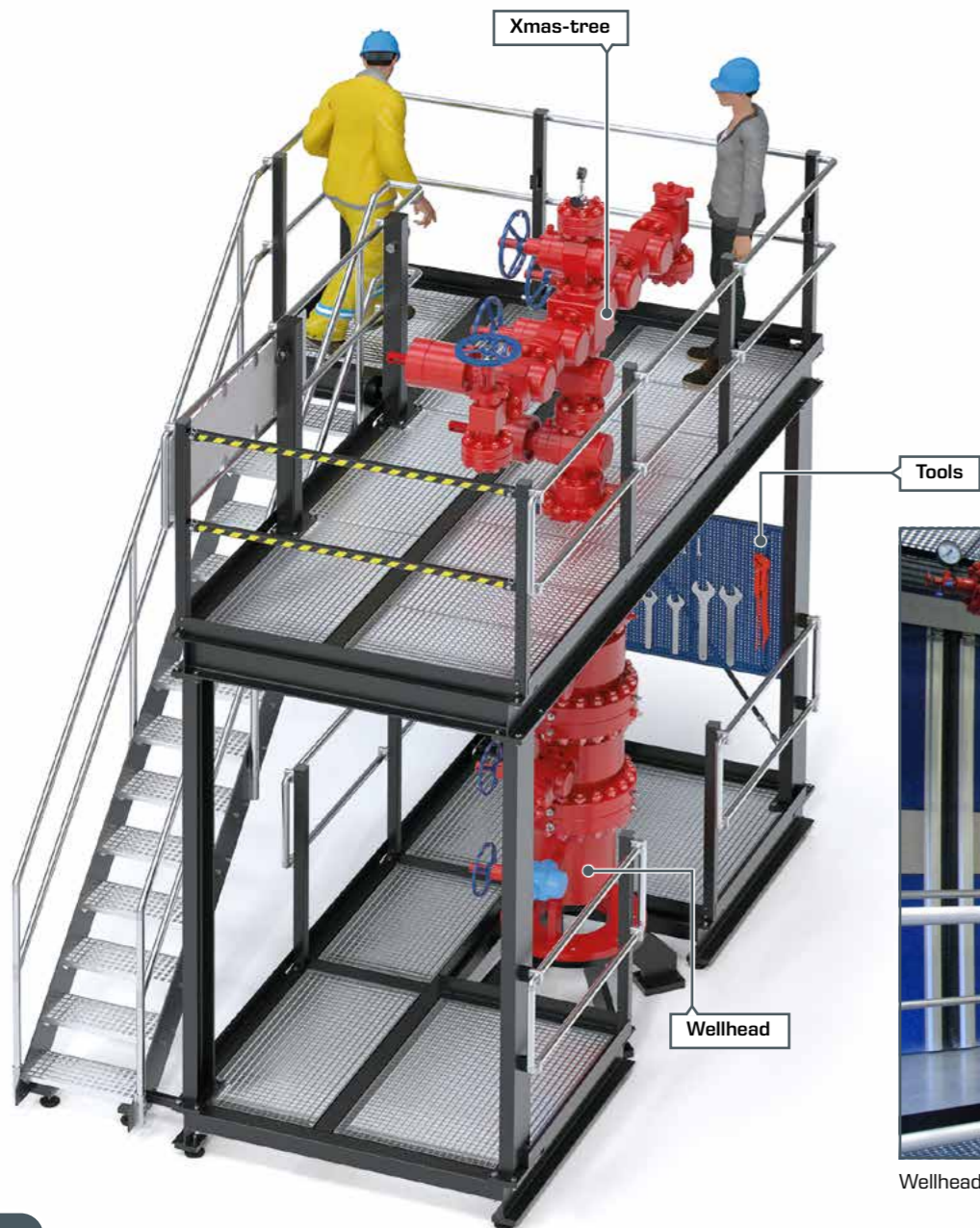

About the product:



Wellhead

ET 805 Steam power plant

The ET 805 Steam power plant is specifically designed for training purposes in the field of power plant engineering with process control systems. Due to the size and complexity of the system, in many aspects the operating behaviour corresponds to that of large-scale plants, thereby enabling training that is as close to the real plant as possible.

This plant can be used to study all relevant properties of a steam turbine power plant. The integrated process control system enables students to practise the operation of an automated power plant. All key variables for the process are clearly displayed in process diagrams and converted into characteristic values.

The steam boiler can be operated with either oil or gas. The superheated steam is fed to a single-stage industrial turbine with speed control. This drives a synchronous generator, which can be operated in grid-connected or stand-alone mode. The exhaust steam from the turbine is condensed and fed back into the feedwater circuit.

The plant consists of four separate modules and can therefore be flexibly adapted to the space available in the laboratory:

- Module 1: steam generator with feed water treatment
- Module 2: steam turbine with generator and condenser
- Module 3: wet cooling tower
- Module 4: control station with process control system

Process control system

Operation of the plant is fully monitored and controlled by the process control system. It is operated via modern touchscreen technology on the control station. The measured values are both output to the process control system with programmable logic controller and sent to a PC for data acquisition, where they are presented and analysed with GUNT software.

A safety system ensures the relevant components are shut-down and error conditions detected in critical operating states.

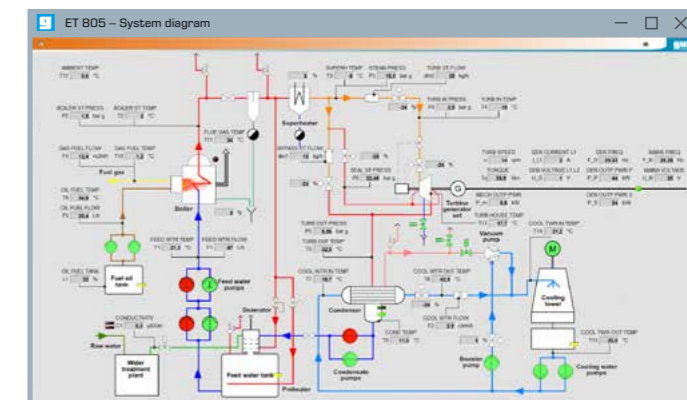

Screenshot of the software

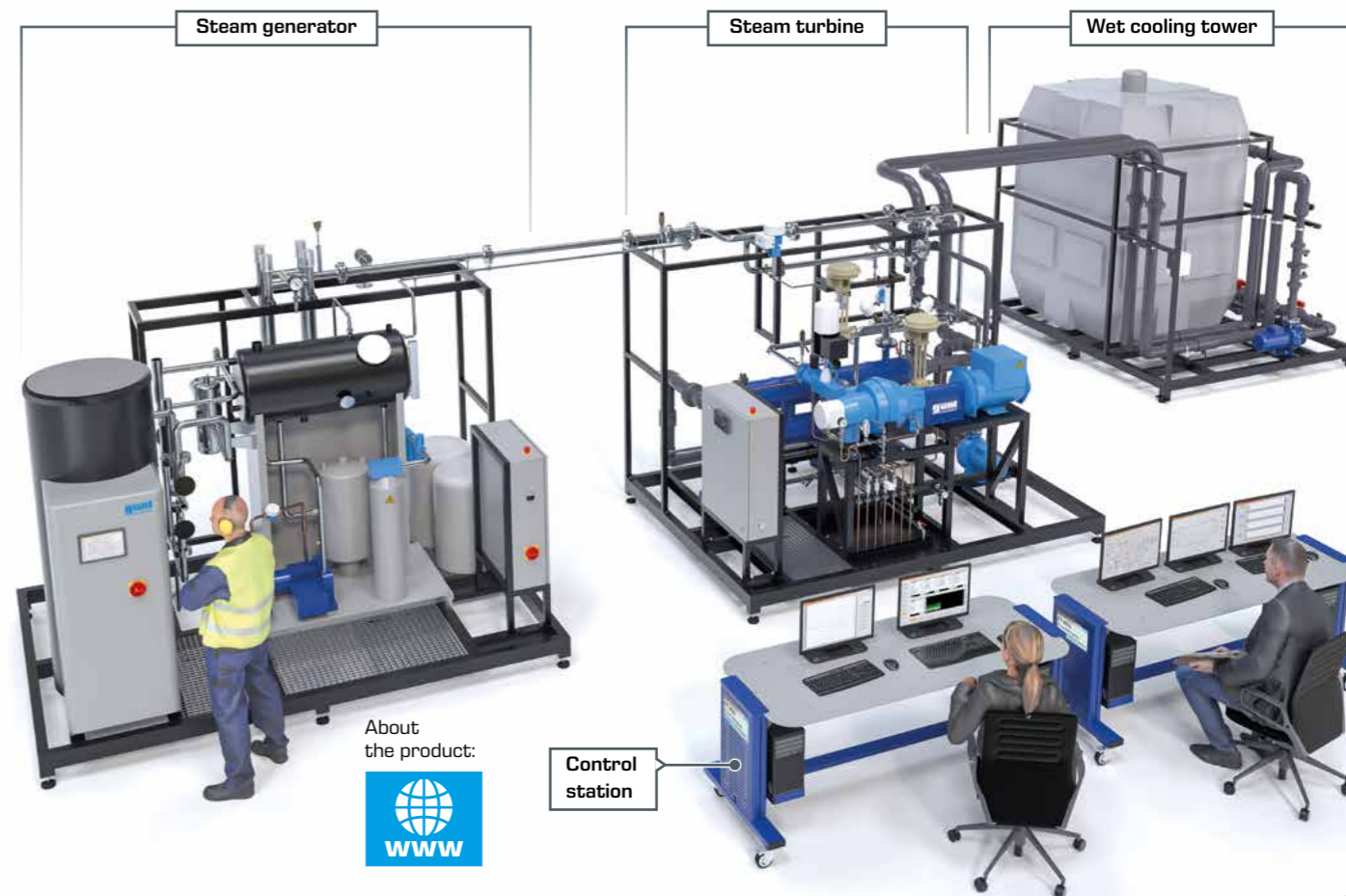

About the product:



The complete GUNT programme – equipment for engineering education



Engineering mechanics and engineering design

- statics
- strength of materials
- dynamics
- machine dynamics
- engineering design
- materials testing

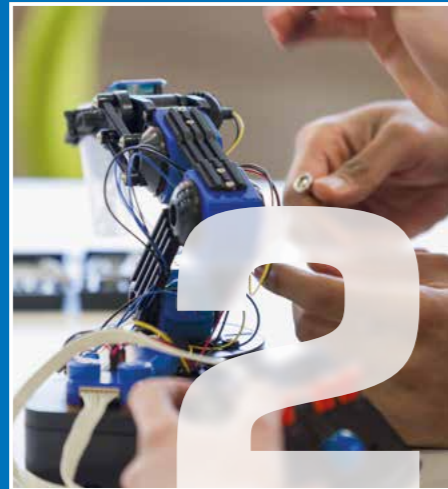

Mechatronics

- engineering drawing
- cutaway models
- dimensional metrology
- fasteners and machine parts
- manufacturing engineering
- assembly projects
- maintenance
- machinery diagnosis
- automation and process control engineering



Thermal engineering

- fundamentals of thermodynamics
- thermodynamic applications in HVAC
- renewable energies
- thermal fluid energy machines
- refrigeration and air conditioning technology



Fluid mechanics

- steady flow
- transient flow
- flow around bodies
- fluid machinery
- components in piping systems and plant design
- hydraulic engineering



Process engineering

- mechanical process engineering
- thermal process engineering
- chemical process engineering
- biological process engineering
- pilot plants



2E Energy & Environment

- Energy**
- solar energy
 - hydropower and ocean energy
 - wind power
 - biomass
 - geothermal energy
 - energy systems
 - energy efficiency in building service engineering
- Environment**
- water
 - air
 - soil
 - waste



Planning and consulting · Technical service
Commissioning and training

HM 250 Fundamentals of fluid mechanics

The digital teaching-learning concept offers an interaction between real experiments and digital teaching with experiment preparation, execution and evaluation. The HM 250 base module provides the basic supply in each case. Measurement, control and communication systems are also provided by the base module.

An extensive selection of optionally available accessories enables a complete training course in the fundamentals of fluid mechanics.

HM 250 Base module

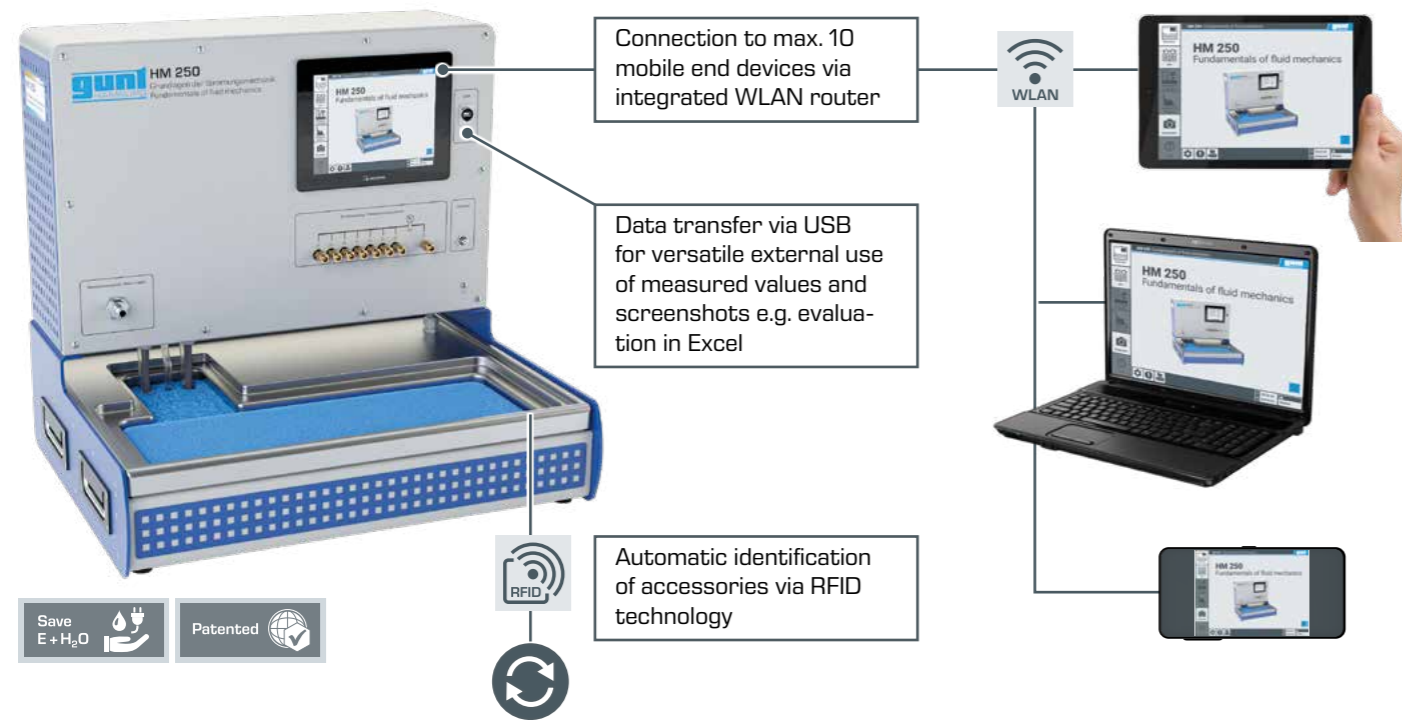

Real experiments – digital media



About the product:



Due to screen mirroring, students can follow the preparation and execution of experiments on end devices and keep sufficient distance from each other.

The laboratory shelf HM 250.90 can be used for space-saving and practical storage of accessories.

- intuitive experiment execution via touch screen (HMI)
- device control with PLC, operation via touch screen or an end device
- integrated WLAN router for operation and control via an end device and for screen mirroring on up to 10 end devices: PC, tablet, smartphone

- automatic identification of accessories via RFID technology
- automatic system configuration including bleeding of the experimental sections
- energy and water saving technics, space-saving setup

Flow in pipes

- laminar / turbulent flow
- effect of the Reynolds number on the flow profile
- visualisation of streamlines using electrolytically generated hydrogen bubbles

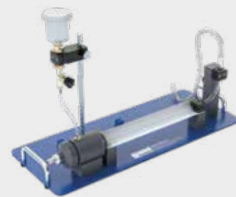

HM 250.01
Visualisation of pipe flow

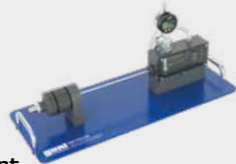

HM 250.02
Measurement of flow profile



HM 250.03
Visualisation of streamlines

Laws of hydrodynamics

- continuity equation and its influencing variables
- principle of linear momentum: experiments on jet forces
- trajectory: examination the trajectory
- Bernoulli's principle: relation between the flow velocity and the different pressures

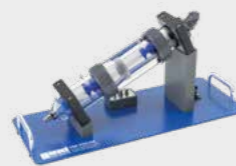

HM 250.04
Continuity equation



HM 250.05
Measurement of jet forces



HM 250.06
Free discharge



HM 250.07
Bernoulli's principle

Friction losses in pipe flow

- resistance coefficients in different pipe elements
- relationship between Reynolds number and pipe friction coefficient
- using the Moody chart
- formation of the flow along the inlet section



HM 250.08
Losses in pipe elements



HM 250.09
Fundamentals of pipe friction



HM 250.10
Pressure curve along the inlet section

Flow in open channels

- energy levels of the water
- hydraulic jump
- energy dissipation in the flume



HM 250.11
Open channel

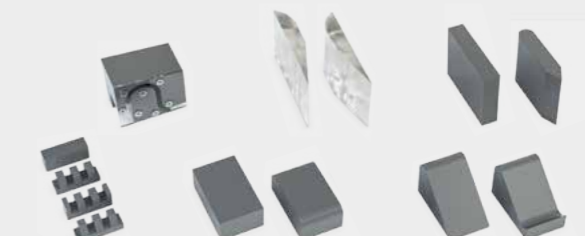

Different magnetic obstacles for demonstration of the flow

WL 110 series experiments on the fundamentals of heat transfer



WL 110
Heat exchanger supply unit

The supply unit produces hot water. All measured values are displayed on the unit's touch screen and can be transmitted via a LAN/WLAN connection.

WL 110.20
Water chiller

The water chiller can be used to operate the heat exchangers under suitable experimental conditions.



- automatic identification of accessories via RFID technology
- energy and water-saving technology, space-saving design

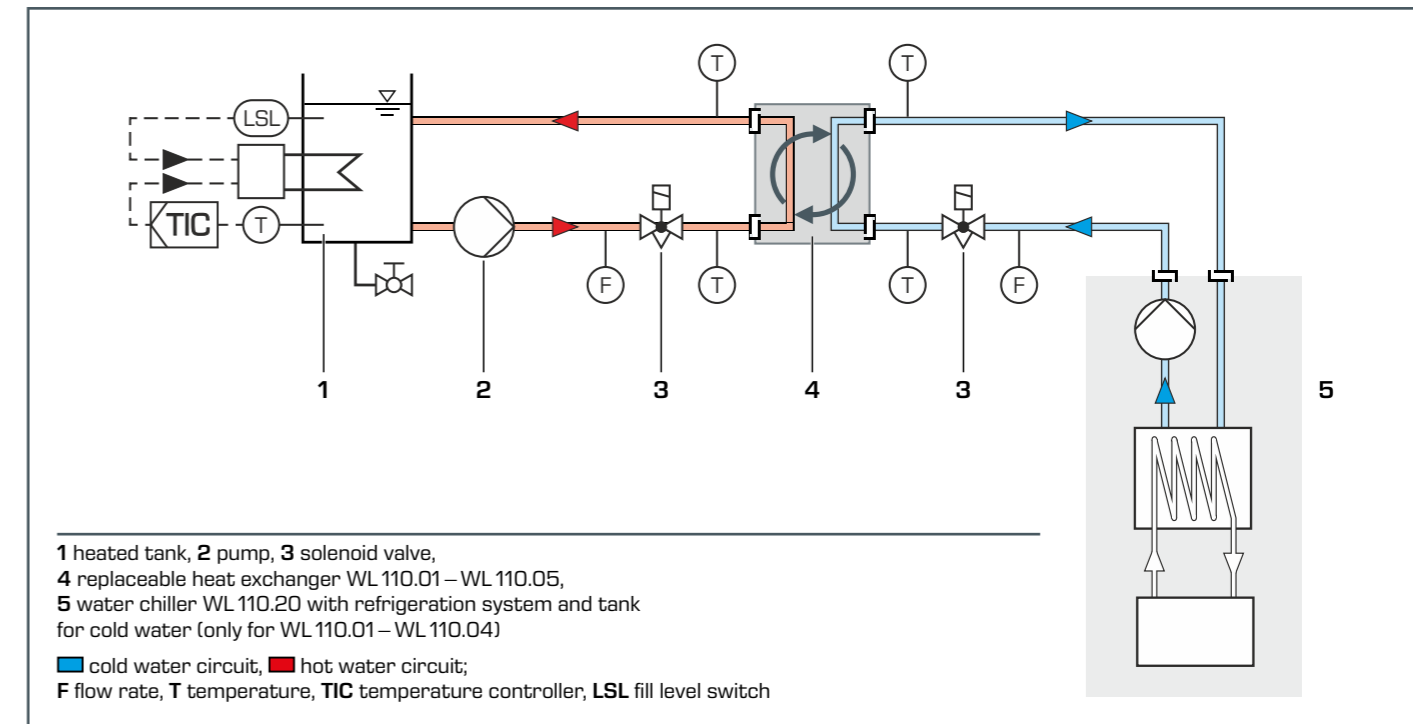

About the product:



WL 110.01
Tubular heat exchanger

- simple design
- transparent outer tube offers visible flow space
- parallel flow and counterflow operation possible



WL 110.02
Plate heat exchanger

- compact design
- parallel flow and counterflow operation possible



WL 110.03
Shell & tube heat exchanger

- transparent jacket pipe
- media flow in cross parallel flow and cross counterflow



WL 110.04
Stirred tank with double jacket and coil

- heating using jacket or coiled tube
- stirrer for improved mixing of medium



WL 110.05
Finned tube heat exchanger

- heat transfer between water and air in cross-flow
- increase of the heat transferring surface due to fins on the pipes

GUNT Thermoline fundamentals of heat transfer



WL 420
Heat conduction in metals



WL 430
Heat conduction and convection

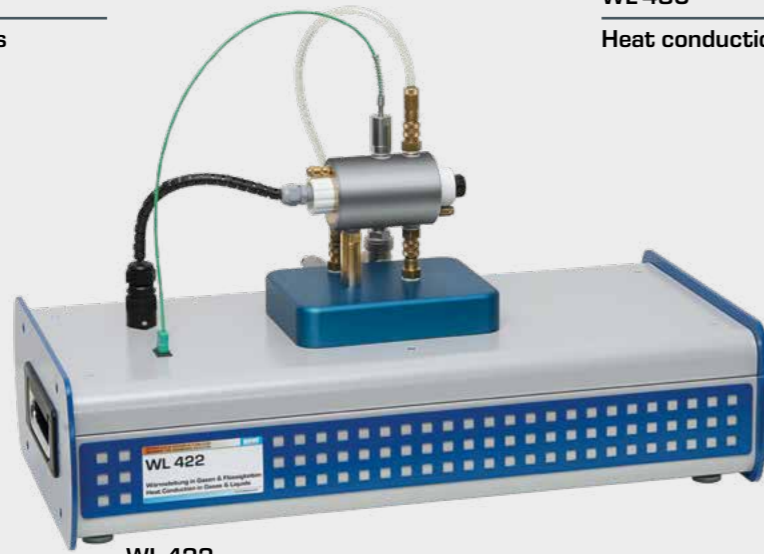

WL 422
Heat conduction in fluids



WL 440
Free and forced convection



WL 460
Heat transfer by radiation

About
the product:



Product overview

CE		
CE 100	Tubular reactor	154
CE 110	Diffusion in liquids and gases	132
CE 115	Fundamentals of sedimentation	023
CE 116	Cake and depth filtration	043
CE 117	Flow through particle layers	044
CE 130	Convection drying	090
CE 200	Flow properties of bulk solids	074
CE 210	Flow of bulk solids from silos	072
CE 220	Fluidised bed formation	078
CE 222	Comparison of fluidised beds	080
CE 225	Hydrocyclone	040
CE 235	Gas cyclone	038
CE 245	Ball mill	059
CE 250	Pneumatic transport	082
CE 255	Rolling agglomeration	068
CE 264	Screening machine	016
CE 275	Gas flow classification	014
CE 280	Magnetic separation	018
CE 282	Disc centrifuge	036
CE 283	Drum cell filter	048
CE 284	Nutsche vacuum filter	050
CE 285	Suspension production unit	052
CE 286	Nutsche pressure filter	051
CE 287	Plate and frame filter press	046
CE 310	Supply unit for chemical reactors	140
CE 310.01	Continuous stirred tank reactor	142
CE 310.02	Tubular reactor	144
CE 310.03	Stirred tanks in series	146
CE 310.04	Discontinuous stirred tank reactor	148
CE 310.05	Plug-flow reactor	150
CE 310.06	Laminar flow reactor	152

CE 320	Stirring	062
CE 322	Rheology and mixing quality in a stirred tank	066
CE 380	Fixed bed catalysis	160
CE 380.01	Flow injection analysis	162
CE 400	Gas absorption	108
CE 405	Falling film absorption	110
CE 520	Cooling crystallisation	120
CE 530	Reverse osmosis	122
CE 540	Adsorptive air drying	112
CE 579	Depth filtration	056
CE 583	Adsorption	116
CE 584	Advanced oxidation	168
CE 587	Dissolved air flotation	030
CE 588	Demonstration of dissolved air flotation	032
CE 600	Continuous rectification	098
CE 602	Discontinuous rectification	100
CE 610	Comparison of rectification columns	102
CE 620	Liquid-liquid extraction	126
CE 630	Solid-liquid extraction	128
CE 640	Biotechnical production of ethanol	196
CE 642	Biogas plant	200
CE 650	Biodiesel plant	164
CE 701	Biofilm process	176
CE 702	Anaerobic water treatment	190
CE 704	SBR process	178
CE 705	Activated sludge process	182
CE 715	Rising film evaporation	092
CE 730	Airlift reactor	186

HM		
HM 142	Separation in sedimentation tanks	026
HM 250	Fundamentals of fluid mechanics	218
HM 250.01	Visualisation of pipe flow	218
HM 250.02	Measurement of flow profile	218
HM 250.03	Visualisation of streamlines	218
HM 250.04	Continuity equation	218
HM 250.05	Measurement of jet forces	218
HM 250.06	Free discharge	218
HM 250.07	Bernoulli's principle	218
HM 250.08	Losses in pipe elements	219
HM 250.09	Fundamentals of pipe friction	219
HM 250.10	Pressure curve along the inlet section	219
HM 250.11	Open channel	219

MT		
MT 174	Sorting plant	017

WL		
WL 110	Heat exchanger supply unit	220
WL 110.01	Tubular heat exchanger	220
WL 110.02	Plate heat exchanger	220
WL 110.03	Shell & tube heat exchanger	220
WL 110.04	Stirred tank with double jacket and coil	221
WL 110.05	Finned tube heat exchanger	221
WL 110.20	Water chiller	220
WL 420	Heat conduction in metals	222
WL 422	Heat conduction in fluids	222
WL 430	Heat conduction and convection	222
WL 440	Free and forced convection	223
WL 460	Heat transfer by radiation	223

Pilotanlagen		
ET 805	Steam power plant	215
IPP	Integrated Pilot Plant	204
IUI	Industrial Unit for Inspection	210
MMTS	Mechanical Maintenance Training Skid	208
MPTR	Main Process Training Rig	209
PPT	Process Pump Trainer	211
PST	Phase Separation Trainer	212
WaXTMT	Wellhead and Xmas-Tree Maintenance Trainer	214
WaXTOT	Wellhead and Xmas-Tree Operation Trainer	213



Contact

G.U.N.T. Gerätebau GmbH
Hanskampring 15 -17
22885 Barsbüttel
Germany

+49 40 6708 54 -0
sales@gunt.de
www.gunt.de

GUNT
TECHNOLOGY
LIMITED

GUNT Technology Limited
Unit 3 · Glenmore Business Park
Colebrook Way
Andover, SP10 3GL

t: +44(0) 1264 33 93 56
e: sales@gunt-technology.co.uk
www.gunt-technology.co.uk



Visit our website
www.gunt.de

